

KIM2

Integration manual



Reference:

KINEIS-MI-22-0397

Issue:

0.2

Date:

Mar. 10, 2023

TABLE OF CONTENTS

1. Introduction	3
A. Revision history	4
B. Related documents	4
C. Versioning	4
D. Next features	4
2. Typical application circuit	5
A. Commands / controls	6
B. Programming and debug	6
C. State transition diagram	7
3. UART Communication	8
A. AT commands syntax	8
B. AT commands description	9
1. General commands	9
a. Ping	9
b. Firmware version	9
c. ID number	10
2. User data commands	11
a. Transmission of data	11
3. User data notifications	12
a. Reception of a data downlink message	12
C. Error responses	12
4. Communication protocol	13
A. Data uplink	13
B. Data uplink acknowledgement	14
C. Data downlink	15

5. Additional information	17
A. Contact & support	17
B. Legal Notices	17
C. Frequency Use	17

PRELIMINARY

1. Introduction

Kinéis products makes satellite connectivity easy to access and it is our goal to make integration and industrialization process as streamlined as possible.

The KIM2 module developed by Kinéis is a low-power transceiver module based on Kinéis standards and fully certified by Kinéis and CNES (French Space Agency). The module is specifically designed for ease of use, to shorten development time and thus decrease time to market. It offers IoT device manufacturers the possibility to integrate their end devices quickly and easily into the Kinéis network and is available for industrialization of satellite connected device in large volumes.

It enables communication with all the Kinéis polar LEO satellites and provides global connectivity to IoT devices for data collection and positioning. The use of Kinéis RF signals and protocols ensures very low power consumption for device within line-of-sight of Kinéis satellites.

This document is an integration manual for the KIM2 transceiver module by Kinéis, complementing the component datasheet.

This manual will bring you information regarding:

- Typical application circuit
- UART interface
- Transmission and reception protocols, including message formatting and communication strategies

For further assistance, feel free to contact Kinéis at the following link: <https://www.kineis.com/contact/>

A. Revision history

Issue	Date	Modifications
0.1		Document creation
0.2		Engineering Samples release for Beta Testing

B. Related documents

- KINEIS-NT-22-0600 - KIM2 Datasheet

C. Versioning

HW release	FW release	Datasheet version	Integration manual version
Engineering samples	KIM2_v1.0	KIM2 Datasheet v0.2	KIM2 Integration manual v0.2

D. Next features

Below is a list of features that will be implemented in the next releases:

- TX modulations:
 - LD-A2 (low-data rate Argos-2: ± 1.1 rad BPSK, 400bits/s)
 - VLD-A4 (very low-data rate Argos-2: ± 1.1 rad BPSK, 200bits/s)
- Low power consumption in Standby, Running and Reception modes
- Software management of EXT_WKUP and KIM_INT pins
- MAC implementation (periodic transmission, satellite pass predictions, satellite detection etc...)
- Automatic user data management ("push-and-forget")

2. Typical application circuit

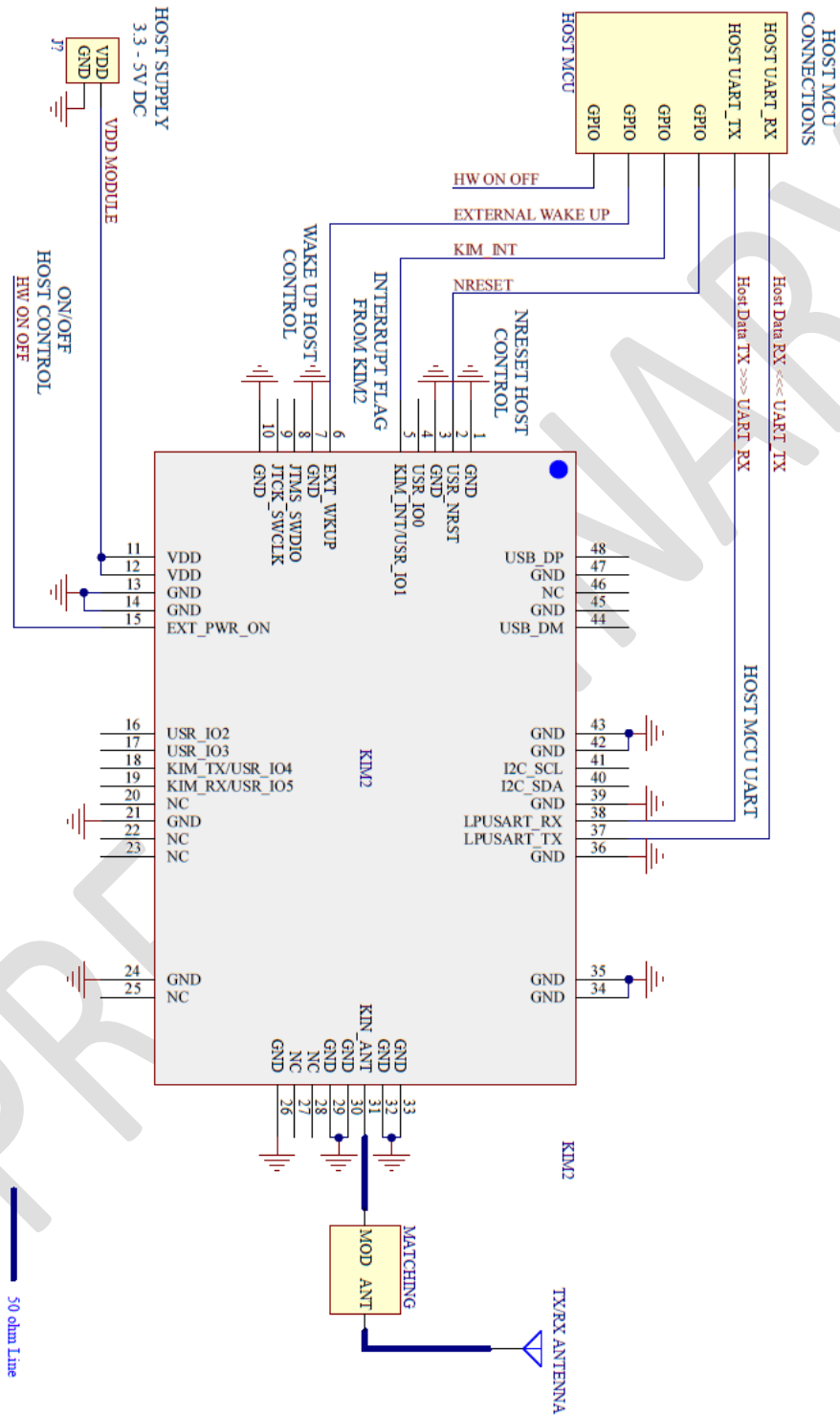

Figure 1: Example of Typical integration of MCU with the KIM2

A. Commands / controls

KIM2 must be powered with 3.3V to 5V DC supply between VDD pins and GND pins, and all GND pins connected to the ground plane.

The microcontroller unit (MCU) can control the KIM2 through UART communication and GPIOs:

- UART interface needs two pins for the two-way communication: LPUSART_TX and LPUSART_RX
- EXT_PWR_ON input pin must be actively controlled to power on the module (High), and can be controlled to put the module in OFF mode (Low) between two transmissions
- USR_Nrst input pin can be used to reset the module

The following pins will be available in future firmware releases:

- EXT_WKUP input pin allows the Host MCU to wake up the module
- KIM_INT output pin is used by the module to wake up the host microcontroller

An antenna matched at 50Ω for the right frequency must be connected on the KIN_ANT pin.

B. Programming and debug

Since the KIM2 is at an engineering sample stage, it is recommended to include the footprint for the programming connector to the host PCB in order to be able to upgrade the firmware with future releases.

The connector reference is TC2030 by Tag-Connect, the schematics are shown in the picture on the right and the footprint is available at <https://www.tag-connect.com/product/tc2030-idc-nl>

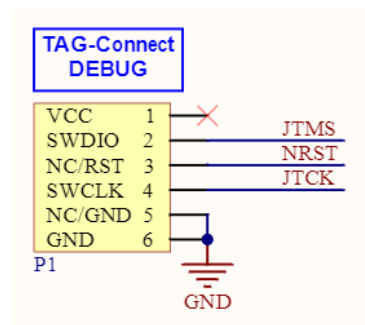

C. State transition diagram

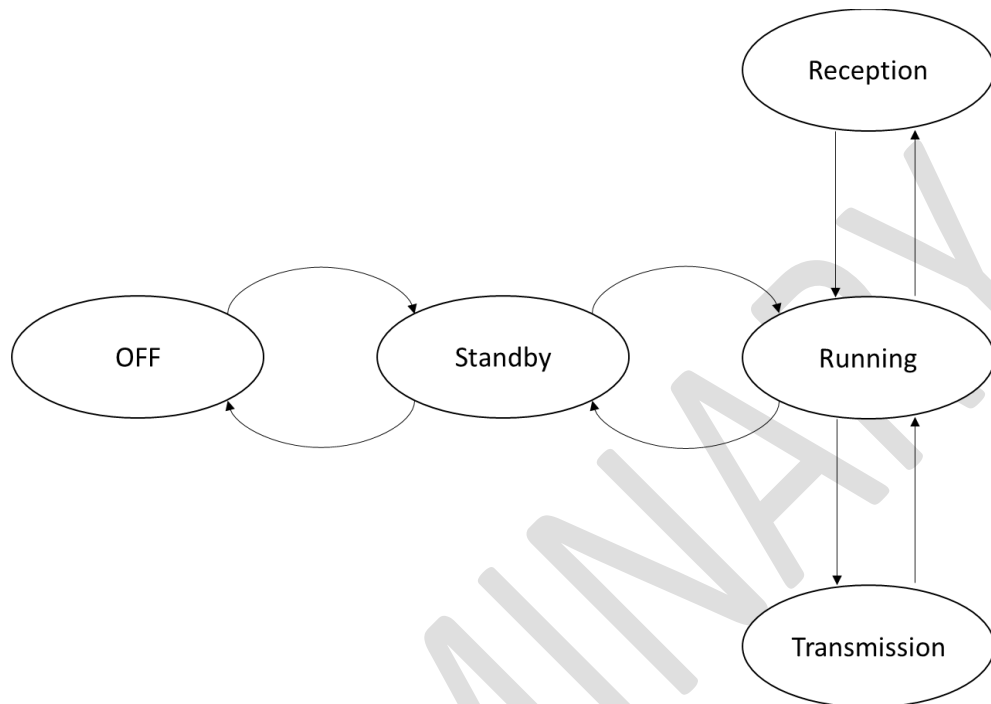

Figure 2: KIM2 state diagram

When the KIM2 is powered at VDD, it can follow different modes:

- **OFF** mode: when the EXT_PWR_EN pin is low, MCU power supply is off, power supply of analog parts are disabled too and the consumption is very low (quiescent current of the internal regulator).
- **Standby** mode: when the ON/OFF pin is high, this is the default mode. The RF digital processor is waiting for AT commands, allowing the transition to the Running Mode. *This mode will be optimized for low power consumption in future releases, but currently drains as much current as the Running mode.*
- **Running** mode: this mode is activated when the RF digital processor receives an AT command, for the duration of execution of the AT command.
- **Transmission** mode: this mode is activated when the RF digital processor receives a transmission AT command. It activates the TCXO and the internal power amplifiers, and a signal is transmitted to the antenna corresponding to the specified Kinéis message.
- **Reception** mode: this mode is activated when a transmission command calls for the reception of a downlink message (acknowledgment or downlink user message)

3. UART Communication

The KIM2 serial interface uses a basic TTL 3.3V level signals with UART protocol (RX link is 5V-tolerant).
 UART interface uses fixed parameters:

SPECIFICATION	DESCRIPTION
Baud Rate	9600
Data bits	8 bits
Parity	None
Stop Bits	1 bit
Flow Control	No

Table 1 : UART Setting

A. AT commands syntax

The AT command or response will be a sentence terminated by <CR><LF> on both sides of communication.

There are three types of extended AT commands:

- Information type read-only commands, allowing to read values saved in the module:
`AT+CMD=?`
- Parameter type commands, allowing to set a value or parameter:
`AT+CMD=<parameter>`
- Action type commands, invoking a function of the equipment, which generally involve more than the simple storage of a value for later use (ex: Transmission command)
`AT+CMD=`

For each AT command, there will be the following possible responses:

- +OK, means the command is accepted and executed
- +ERROR=<errorno> means an error occurred during the execution of the command
 - Possible values for <errorno> parameter are detailed in §3 Error responses

Spontaneous notifications can also be sent from the module with the format `+CMD=<parameter>`.

Timing constraints: Once an AT command has been sent to module, one shall not send again a new command until previous has been completed with a response.

User shall wait at minimum 10ms before sending a new command after previous is completed.

B. AT commands description

1. General commands

a. Ping

PING – Communication test	
AT+PING=?	Test the communication with the KIM2

b. Firmware version

FW – Read Firmware version	
AT+FW=?	<p>Read the firmware version from KIM2 module</p> <p>Answer: +FW=<fw_version></p> <p>Parameter:</p> <ul style="list-style-type: none"> • <fw_version> – Firmware version flashed into the module <ul style="list-style-type: none"> ○ Format: KIM2_vx.x

c. ID number

ID - Read Kinéis ID number	
AT+ID=?	<p>Read the Kinéis hexadecimal ID number of the module</p> <p>Answer: +ID=<id_number></p> <p>Parameters:</p> <ul style="list-style-type: none">• <id_number> - Kinéis ID number in hexadecimal format (7 digits)

2. User data commands

a. Transmission of data

TX – Transmission of data	
<p>AT+TX=<data> [,<att_bitmap>]</p>	<p>Transmit a message</p> <p>Parameter:</p> <ul style="list-style-type: none"> • <data> – user data to be transmitted, in a hexadecimal string <ul style="list-style-type: none"> ○ Length must be 19 Bytes for data uplink ○ Length must be 17 Bytes for data uplink acknowledgment or data downlink message reception <p><i>If the data specified with the AT+TX command does not follow the proper data length, the data will be zero-padded or truncated to reach the correct length.</i></p> <ul style="list-style-type: none"> • <att_bitmap> – attribute bitmap as two hexadecimal digits for the communication protocol (see §4 Communication protocol) <ul style="list-style-type: none"> ○ 0x00: data uplink (default value) ○ 0x01: data downlink ○ 0x04: data uplink acknowledgment
<p>+TX=<status>, <data></p>	<p>Answer from the module after the transmission of data</p> <p>Parameters:</p> <ul style="list-style-type: none"> • <status>: integer that specifies the status <ul style="list-style-type: none"> ○ 0: no error, status depending on communication protocol <ul style="list-style-type: none"> ▪ Data uplink: single transmission has been performed ▪ Data downlink: single transmission has been performed (to trigger the data downlink message) ▪ Data uplink acknowledgment: single transmission has been performed and acknowledgment has been received from the satellite ○ Other: see error codes in §3 Error responses • <data> – user data transmitted, in a hexadecimal string

3. User data notifications

a. Reception of a data downlink message

DL – Reception of data downlink message	
+DL=<data>	Reception of a data downlink message Parameter: <ul style="list-style-type: none"> • <data> – user data in a hexadecimal string

C. Error responses

ERROR – Error response	
+ERROR= <error_code>	Error response from the module to an AT command Parameter: <error_code> – an integer that specifies the error <ul style="list-style-type: none"> • 1: Unknow error • 2: format of parameter is incorrect • 3: parameters are missing • 4: too many parameters • 5: value of the parameter is incompatible • 6: AT command is unknown • 20: user data length is invalid • 30: reception timeout (for data downlink or uplink acknowledgment) <i>In case of any other value, please reach out to Kinéis technical support</i>

4. Communication protocol

Please visit <https://connect.kineis.com/transmission-strategy> to find out the best strategy to implement according to your use case requirements.

In the firmware release KIM2_v1.0 for engineering samples, no timeout was implemented in reception mode. To stop the reception, please reset the module. The downlink message should be received within 15 seconds after the transmission of the triggering uplink message.

The different scenarios implemented in the KIM2 are described below.

A. Data uplink

The data uplink service consists in data transmission only, with messages of **19 Bytes**. In this scenario, the module is not aware whether the satellite has well received the message or not. Since the module only performs a single transmission, an adapted transmission strategy should be implemented in order to maximize the probability of reception of the message by the satellite.

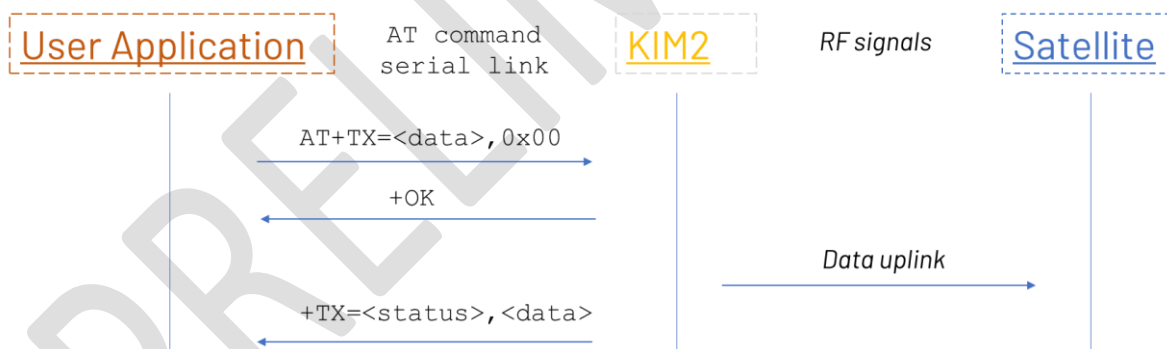

Parameter `<status>` has the value 0 if the message is well transmitted by the module (no error). Other possible values are detailed in §3 **Error responses**

B. Data uplink acknowledgement

The data uplink acknowledgement service consists in data transmission, with messages of **17 Bytes**, and reception of an acknowledgment from the satellite to confirm the correct reception of the message. After the transmission of the message, the module switches to reception mode to receive the data uplink acknowledgement.

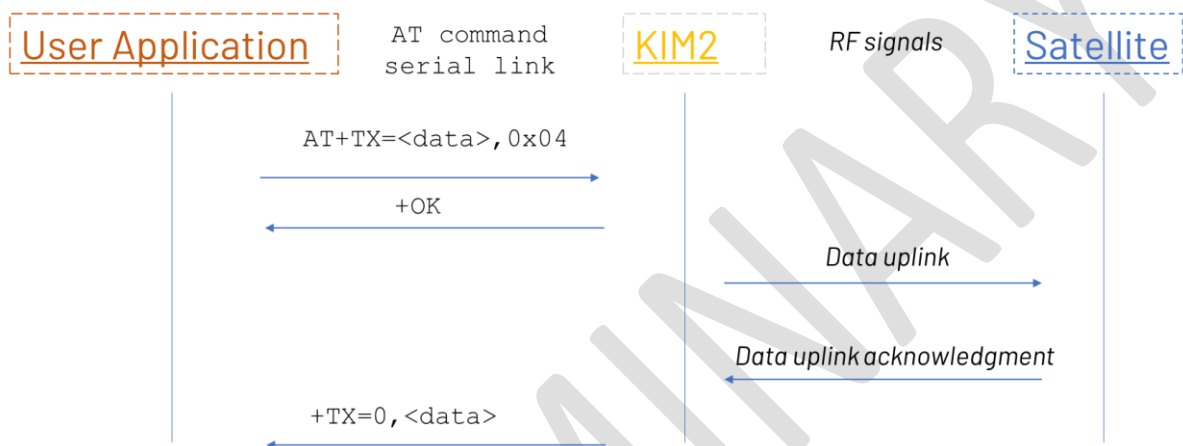

If the data uplink acknowledgement is not received by the module after the timeout period, the response from the module to the user application has the parameter `<status>` with value 30 to indicate a timeout. This situation can happen in two cases:

- When the uplink data message is not received and thus the uplink data acknowledgment not transmitted by the satellite:

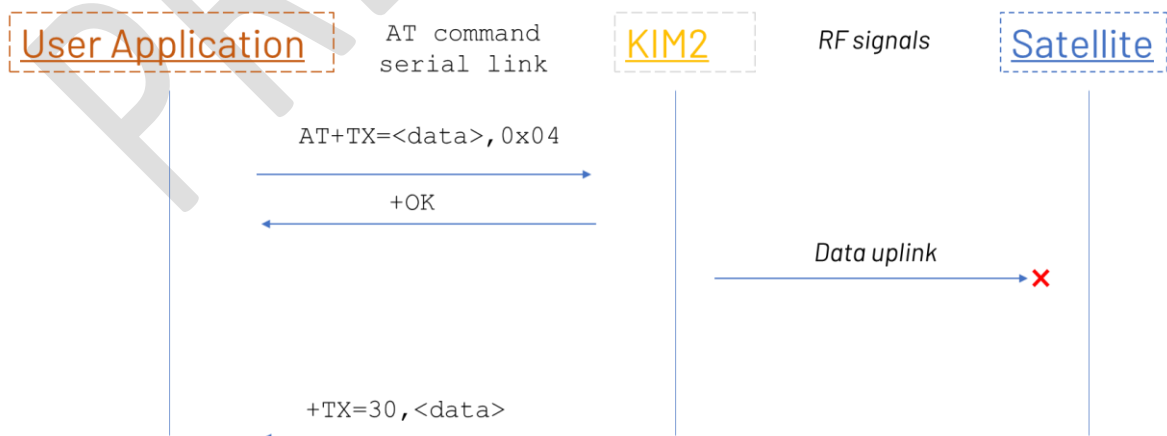

- When the uplink data message is well received by the satellite, the uplink data message acknowledgement is transmitted by the satellite but not received by the module

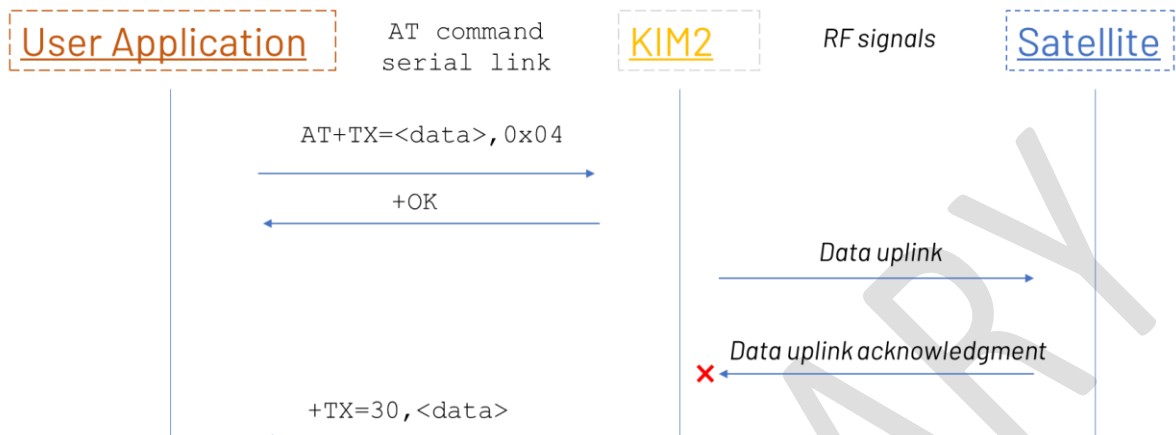

C. Data downlink

The data downlink service consists in receiving a data downlink message, previously been programmed by the end user, from the satellite. The reception of a data downlink message must be triggered by an uplink message of **17 Bytes** of user data. After the transmission of the message, the module switches to reception mode to receive the data downlink message, then back to transmission mode to transmit the data downlink acknowledgment.

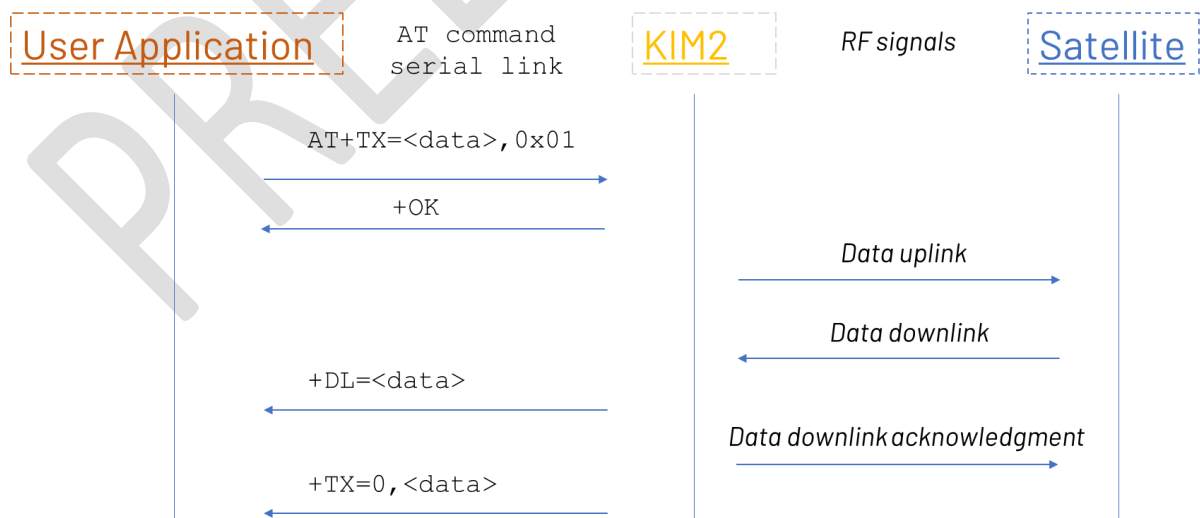

If the data downlink is not received by the module after the timeout period, the response from the module to the user application has the parameter `<status>` with value 30 to indicate a timeout. This situation can happen in two cases:

- When the uplink data message is not received and thus the downlink data message not transmitted by the satellite:

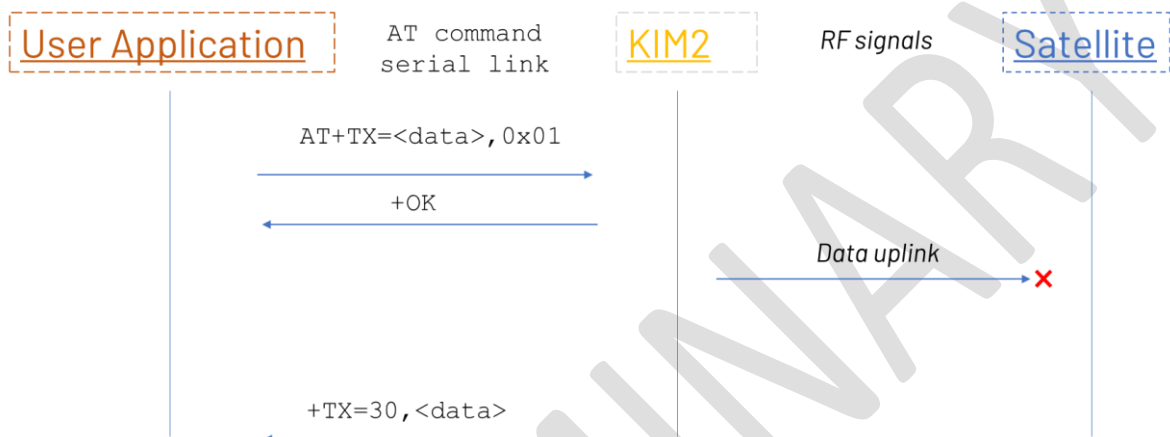

- When the uplink data message is well received by the satellite, the downlink data message is transmitted by the satellite but not received by the module:

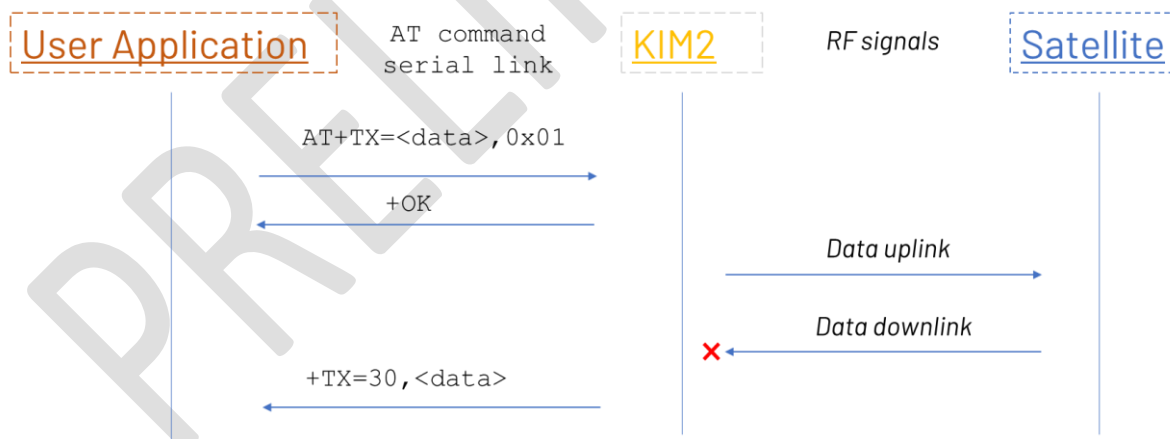

5. Additional information

A. Contact & support

Product information, technical support and commercial contact are available from Kinéis at the following link: <https://www.kineis.com/contact/>

B. Legal Notices

Kinéis reserves the right to make changes, corrections, enhancements, modifications, and improvements to their products and/or to this document at any time without notice. Information in this document supersedes and replaces information previously supplied in any prior versions of this document.

Kinéis products are warranted as per contract and general purchase condition, as long as they are used under the conditions described in the datasheet and the integration manual.

“Kinéis” and the Kinéis logo are trademarks of Kinéis SAS. For any communication or marketing needs, please contact our team.

C. Frequency Use



The frequency band 401-403MHz is designated by International Telecommunication Union (ITU) as usable for Global satellite data collection and positioning system as ARGOS.

The Centre National Etudes Spatiales (CNES) is in charge of Argos program. The CNES endorses Kinéis to operate the frequency band allocated to Argos.

This frequency band is usable with limitations. Please contact Kinéis to verify that your application with KIM2 respect those limitations.