



BIGJOE Manufacturing Company
7225 NORTH KOSTNER AVENUE • LINCOLNWOOD, IL 60646

TECHNICAL MANUAL

**WALKIE RIDER
TRUCK
MODEL WRT-40 AND
WRT-60 SERIES LIFT TRUCKS**

Contract _____
Publication Number: WRT0782

Model No. _____ Serial No. _____

Date of Issue _____

TABLE OF CONTENTS

SECTION	PAGE	SECTION	PAGE
I DESCRIPTION			
1-1	Introduction	1-1	
1-2	Description	1-1	
1-3	General	1-1	
1-4	Capabilities	1-1	
1-5	Safety Features	1-1	
II OPERATION			
2-1	General	2-1	
2-2	Operating Precautions	2-1	
2-3	Operation	2-1	
2-4	Steering Arm Controls	2-1	
2-5	Grab Handle Controls	2-2	
2-6	Starting and Driving	2-3	
2-7	Braking and Stopping	2-4	
2-8	Operating Lift and Lower	2-5	
2-9	Loading (Typical)	2-5	
2-10	Unloading	2-6	
2-11	Parking	2-6	
III MAINTENANCE AND MAINTENANCE PARTS			
3-1	General	3-1	
3-2	Part Number Identification	3-1	
3-3	Preventive Maintenance	3-1	
3-4	Inspection and Service	3-1	
3-5	Battery Care	3-3	
3-6	Lubrication	3-3	
3-7	Troubleshooting	3-6	
3-8	Adjustment and Repair	3-11	
3-9	Steering Arm	3-11	
3-10	Grab Handle Replacement	3-14	
3-11	Disc Brake	3-16	
3-12	Transmission and Drive Wheel Replacement	3-19	
3-13	Load Wheel and Bearing Replacement	3-28	
3-14	Load Wheel Housing Replacement	3-28	
3-15	Lift Linkage Repair	3-39	
3-16	Roller Removal	3-35	
3-17	Caster Bearing Replacement	3-35	
3-18	Caster Wheel Bearing Replacement	3-37	
3-19	Base and Frame	3-37	
3-20	Belly-Button Switch Adjustment	3-40	
3-21	Control Head Switch Replacement	3-41	
3-22	Control Shaft Cable Replacement	3-44	
3-23	Grab Handle Cable Replacement	3-45	
3-24	Drive Motor Removal	3-46	
3-25	Drive Motor Repair	3-48	
3-26	Pump Motor Removal	3-49	
3-27	Pump Motor Repair	3-50	
3-28	Electrical Control Panels	3-51	
3-29	Coil Replacement, All Contactors	3-51	
3-30	Contact Replacement	3-60	
3-31	Core or Return Spring Replacement	3-65	
3-32	Dead-Man Switch Adjustment	3-65	
3-33	Battery Connector Group Replacement	3-66	
3-34	Hydraulic System	3-68	
3-35	Skid Adapter and Load Backrest	3-73	
3-36	Battery Rollout Tray	3-74	

LIST OF ILLUSTRATIONS

FIGURE	PAGE	FIGURE	PAGE
1-1	Walkie Rider Truck (Models WRT-40 and WRT-60) . . .	1-0	
2-1	Steering Arm Controls	2-2	
2-2	Grab Handle Controls	2-3	
2-3	Mechanical Brake Application	2-5	
3-1	Lubrication Points	3-4	
3-2	Wiring Diagram	3-9	
3-3	Steering Arm	3-12	
3-4	Grab Handle Assembly	3-15	
3-5	Mechanical Brake Adjustment	3-16	
3-6	Disc Brake and Linkage	3-18	
3-7	Transmission and Drive Wheel	3-22	
3-8	Backrest/Fork Assembly	3-30	
3-9	Caster Assembly	3-36	
3-10	Base and Frame	3-38	
3-11	Belly-Button Safety Switch	3-40	
3-12	Control Head Assembly	3-42	
3-13	Switch Cam	3-44	
3-14	Control Shaft Cable Replacement	3-45	
3-15	Grab Handle Cable Replacement	3-46	
3-16	Drive Motor	3-47	
3-17	Pump Motor	3-51	
3-18	Electrical Control Panel (WRT-40)	3-52	
3-19	Electrical Control Panel (WRT-60)	3-56	
3-20	70-Ampere Contactor (WRT-40 and WRT-60)	3-61	
3-21	50-Ampere Contactor (WRT-60)	3-62	
3-22	Coil and End Frame Reassembly	3-63	
3-23	Dead-Man Switch Adjustment	3-66	
3-24	Battery Connector Group	3-67	
3-25	Hydraulic System	3-69	
3-26	Pump-Motor-Reservoir Assembly	3-70	
3-27	Lift Cylinder	3-72	
3-28	Skid Adapter and Load Backrest	3-73	
3-29	Battery Rollout Tray	3-74	

LIST OF TABLES

TABLE	PAGE	TABLE	PAGE
2-1	Steering Arm Controls	2-2	
2-2	Grab Handle Controls	2-3	
3-1	Inspection and Service Chart	3-2	
3-2	Recommended Lubricants	3-5	
3-3	Lubrication	3-5	
3-4	Troubleshooting Chart	3-6	
3-5	Transmission Fasteners Torque Requirements	3-27	

PREPARATION FOR USE

Remove cardboard banded to forks. Check truck for scratches and dents. Inspect for oil leaks and loose wiring connections.

Before the truck is moved, the battery must be checked, recharged if necessary, and connected. If the truck was ordered without a battery, a freshly charged battery of adequate size and proper weight must be installed. Refer to para. 3-5, Battery Care, in Section III for battery checking instructions. Connect battery quick-disconnect plug to receptacle located near battery on the frame of the truck.

Refer to section II for operating instructions to test the following controls:

- Steering Arm Return Spring
- FORWARD Speed Control
- REVERSE Speed Control
- Belly-Button Guard
- Grab Handle Controls
- Lift Controls
- Lower Controls
- Dynamic Brake Controls
- High-Speed Switch

If you do not obtain the proper results, or if improper operation occurs, refer to "Troubleshooting" and "Repair" in Section III. The adjustment and repair procedures are supplemented with illustrations and parts lists. All parts identification illustrations have been integrated with the text rather than separated into a separate section.

NOTE: This manual has been updated to reflect the latest changes for the WRT-40 and WRT-60. Revisions have been footnoted on the pages where the revisions have been made.

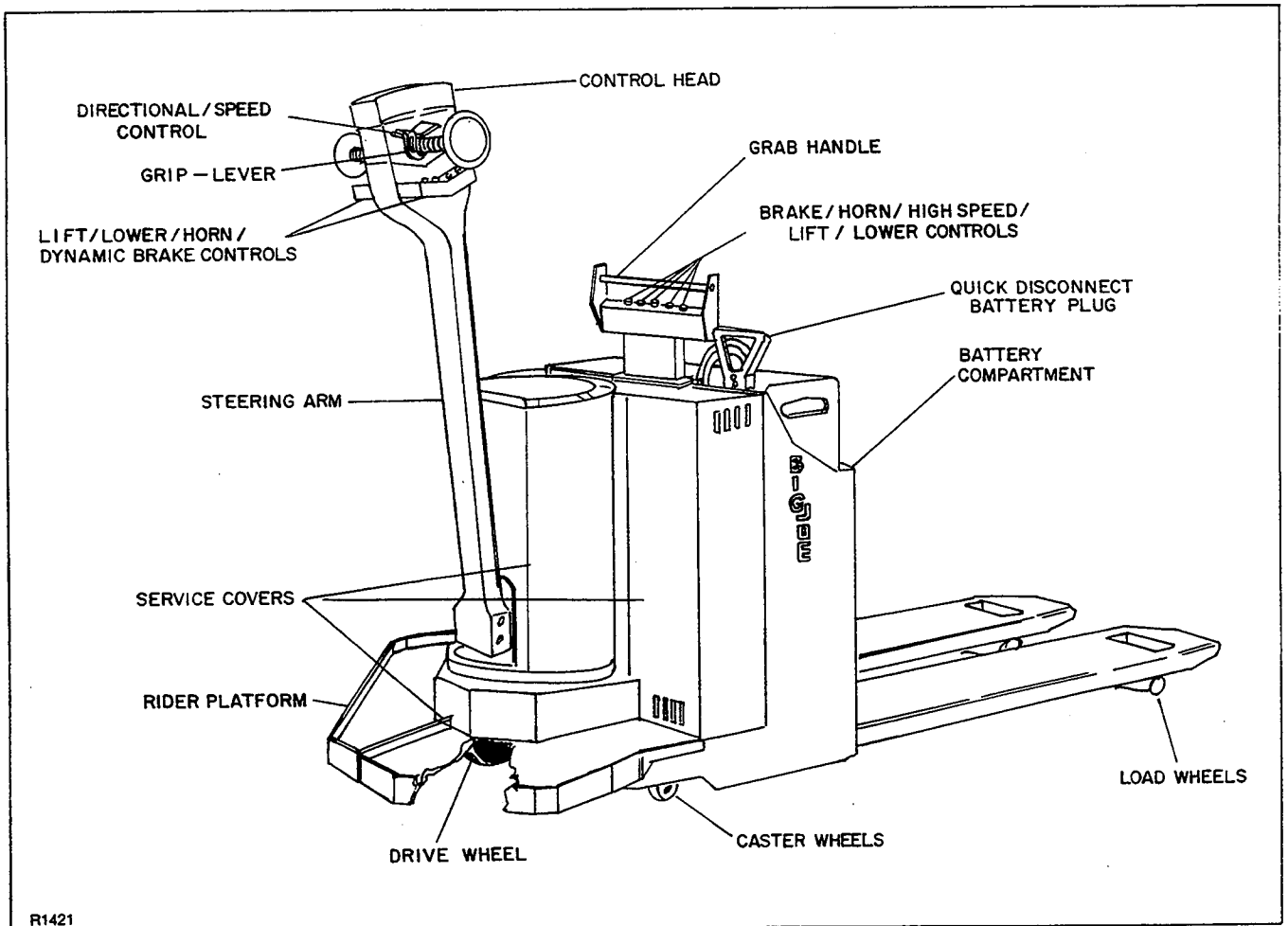

R1421

Figure 1-1. Walkie Rider Truck (WRT-40 and WRT-60)

SECTION I

DESCRIPTION

1-1. INTRODUCTION. (Figure 1-1)

This manual describes the Walkie Rider Truck (Models WRT-40 and WRT-60) manufactured by Big Joe Manufacturing Company, Lincolnwood, Illinois 60646. The WRT truck (figure 1-1) is described in detail, with instructions for operation, lubrication, adjustment, and repair.

By following the recommendations contained in this manual, you will receive many years of dependable service from your truck.

1-2. DESCRIPTION.

1-3. General.

The WRT Truck efficiently lifts and moves heavy pallet-mounted loads. By using the simple steering arm and pushbutton/rocker switches located in the control head as well as the pushbuttons on the grab handle, the operator moves, stops the truck and operates the lift/lower mechanism in both the walking and riding modes of operation.

The battery-powered truck operates quietly and without exhaust fumes, allowing operation in closed areas without special provisions for ventilation. This manual covers trucks having 12-volt or 24-volt electrical systems.

1-4. Capabilities.

The lifting capacity of the Truck is 4000 pounds for the WRT-40 and 6000 pounds for the WRT-60. The main difference in the construction of these models is in the electrical panel, the WRT-60 using larger electrical contactors. Both models are actuated by either a 12-volt battery-powered hydraulic system or a 24-volt system. The lift height of the forks is 9 inches.

1-5. Safety Features.

This Truck is designed and engineered to provide maximum safety for operator and payload. Some of the safety features incorporated into the design are:

- Steering arm automatically applies brake and cuts-off drive power when released.
- Belly-button reverses the motion of the truck switch should the operator accidentally pin himself against a wall or obstruction when backing up in the walking mode of operation.

- Skid-resistant operators platform.
- Externally accessible quick-disconnect battery plug.
- Separately fused control circuits and power circuits.
- Horn.
- High Speed pushbutton switch on 24-volt systems to control high speed when in the walking mode.
- All control functions are operable with either hand and are accessible without removing hands from the steering arm when walking and the steering arm and the grab handle when riding.

SECTION II OPERATION

2-1. GENERAL.

This section gives detailed operating instructions for the Walkie Rider Truck. The instructions are divided into the various phases of operations, such as operating lift, traveling, and stopping. Precautions are included to highlight safe operation.

2-2. OPERATING PRECAUTIONS.

Improper operation may result in operator injury, or damage to the truck and/or load. Observe the following precautions when operating the truck.

1. Do not exceed the rated capacity. Overloading may result in damage to the hydraulic, electrical and structural components.
2. Do not pick up loads on the tips of the forks.
3. Pick up loads on both forks. Do not pick up loads on only one fork.
4. Use care when moving a load. Driving the truck too quickly around a turn may upset the balance of the load.
5. Apply the mechanical brake gently except in cases of emergency.
6. Observe all operating precautions indicated on the trucks WARNING DECAL.

2-3. OPERATION.

The Walkie Rider Truck is operated from a walking position or a riding position. In the walking mode of operation, all controls needed by the operator to safely and efficiently maneuver truck and load have been designed into the control head at the end of the steering arm. In the riding mode of operation, the steering arm is used to start and stop the truck and to steer the truck, and the grab handle controls are used to brake, use the horn, control high speed, and lift or lower the backrest/fork assembly.

2-4. Steering Arm Controls. (Figure 2-1)

The switch boxes, which are located on both sides of the control head, have parallel controls to allow operation from either side. Each box has a dynamic brake, horn, and lift and lower pushbutton switches. The control head contains the forward/reverse speed control, the belly-button guard, and the high speed switch on 24 volt systems. Figure 2-1, Steering Arm Controls, illustrates the controls, and Table 2-1 lists their functions.

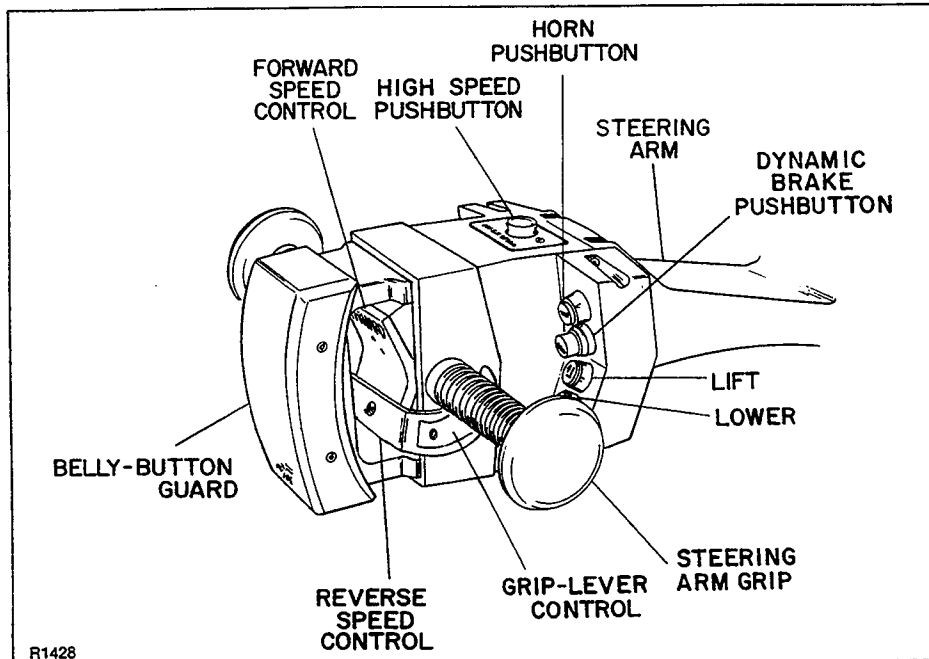

Figure 2-1. Steering Arm Controls

Table 2-1. Steering Arm Controls

CONTROL	FUNCTION
Speed Control	A switch assembly that energizes the truck motor for forward or reverse motion. 3 selectable detented speed settings are available in both forward and reverse.
Horn	A pushbutton switch that energizes the audible warning horn.
Brake	A pushbutton switch that energizes the dynamic brake circuit.
Lift	A pushbutton switch that energizes the pump motor to lift the forks.
Lower	A pushbutton switch that actuates a solenoid to allow the forks to descend.
Belly-Button Guard	Actuates a switch to quickly change direction of a truck from moving backward to moving forward in low speed.
High Speed Pushbutton (on 24V Controls)	A pushbutton switch that selects high speed while operating in the walking mode.

2-5. Grab Handle Controls. (Figure 2-2)

The switches which are located on the grab handle are used to control truck functions in the riding mode of operation. The switch box contains the dynamic brake, horn, high speed, lift and lower pushbuttons. Figure 2-2, Grab Handle Controls, illustrates the controls, and Table 2-2 lists their functions.

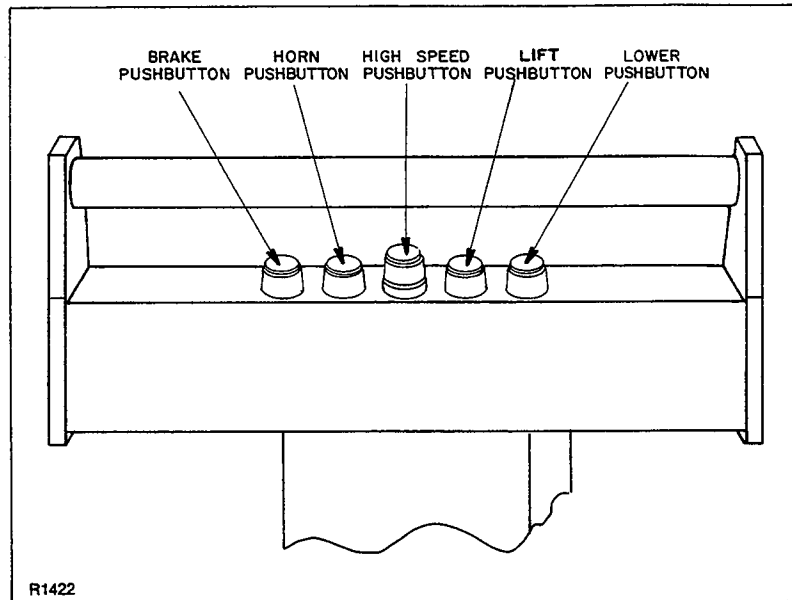

Figure 2-2. Grab Handle Controls

CONTROL	FUNCTION
Horn	A pushbutton switch that energizes the audible warning horn.
Brake	A pushbutton switch that energizes the dynamic brake circuit.
Lift	A pushbutton switch that energizes the pump motor to lift the forks.
Lower	A pushbutton switch that actuates a solenoid to allow the forks to descend.
High Speed Pushbutton	A pushbutton switch that selects high speed operation.

Table 2-2. Grab Handle Controls

2-6. Starting and Driving

The speed control (see figure 2-1) located on the control head provides fingertip control for driving the truck. As the upper portion of the speed control is pressed, it actuates microswitches for first speed and forward direction. Pressing the speed control farther actuates a switch for second speed and further pressure actuates a switch for third speed. On trucks with 24 volt electrical systems, the third speed is controlled by a High Speed pushbutton switch. These trucks will not switch into third speed unless the pushbutton switch is held in the depressed position. Release of the High Speed pushbutton will cause the truck to switch back to second speed regardless of the position of the speed control. The lower portion of the speed control governs the two reverse speeds in the same manner on 24 volt systems and three reverse speeds on 12 volt systems.

The grab handle controls (see figure 2-2) provide fingertip control for driving the truck in the rider mode of operation. The starting of the truck in forward or reverse, as well as the steering of the truck, is done with the speed control and the control head similar to the walking mode. High speed selection, dynamic braking, use of the horn and lifting or lowering of the backrest/fork assembly is controlled using the grab handle controls.

1. When carrying no load, lower the forks fully for maximum stability when traveling.
2. In the walking mode, grasp the grips of the steering arm so that the speed control can be comfortably operated by either thumb.
3. In the riding mode, keep both feet on the operator's platform and do not carry passengers. Place one hand on the steering arm grip and the other on the grab handle.
4. Lower the steering arm to disengage the mechanical brake and energize the electrical circuits.
5. To move forward, slowly press the upper (FORWARD) portion of the speed control. Press this control farther to increase speed. When in the riding mode, a Grip-Lever is provided to aid in actuating the directional/speed control (see figure 2-1).
6. To stop, release the speed control and allow the spring-loaded steering arm to return to the upright position, or gently press the steering arm down to a horizontal position. Either action applies the mechanical brake and de-energizes the electrical controls.
7. To travel in reverse, lower steering arm and slowly press lower (REVERSE) portion of speed control. Press this control farther to increase speed in reverse.

NOTE In the walking mode, the belly-button guard activates a switch which will reverse the motion of the truck should the operator accidentally pin himself against a wall or obstruction when backing up.

2-7. Braking and Stopping.

After release of the speed control, the truck will coast to a halt. For stopping on demand, each truck has two separate braking systems: the primary mechanical disc-type service brake and the dynamic brake.

a. Mechanical Brake. (Figure 2-3)

When the steering arm is moved to the vertical or horizontal position, the mechanical brake is applied (see figure 2-3). All traction power is shut off in these positions. By leaving the steering arm in the upright position, the mechanical brake acts as a parking brake. When released, the handle is raised to the upright position by spring action so that dead-man braking occurs.

b. Dynamic Brake.

CAUTION The dynamic brake pushbutton should not be held in place any longer than necessary to bring the truck to a stop. Keeping it depressed may blow the 40-Amp fuse.

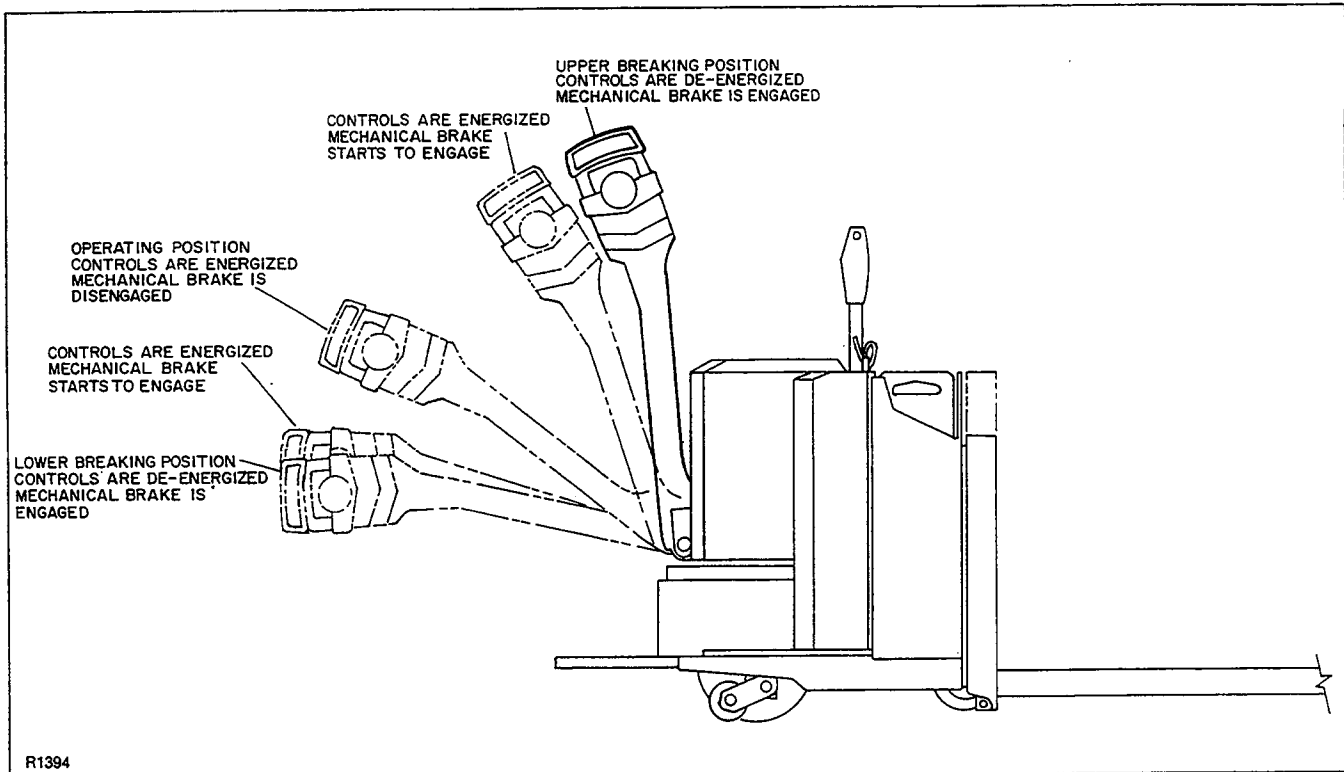

Figure 2-3. Mechanical Brake Application

The dynamic brake is a secondary braking system, completely independent from the mechanical brake, operating only when the steering arm is away from the upright or horizontal positions. Pressing the **BRAKE** pushbutton on either the left side or right side switch box or the **BRAKE** pushbutton on the grab handle applies a dc voltage across the drive motor field coils stopping the motor. The dynamic brake will bring the truck to a smooth jar-free stop, except on inclines.

2-8. Operating Lift and Lower.

The lift and lower pushbuttons regulate the lifting and lowering of the forks.

CAUTION To avoid excessive heating and aeration of hydraulic oil, always release the lift pushbutton immediately when the forks reach maximum elevation.

1. To lift the forks, depress lift pushbutton and hold it until the forks reach the desired height; then release the pushbutton.
2. To lower the forks, depress the lower pushbutton and hold it until the forks are lowered.

2-9. Loading.(typical)

1. Lower forks **ALL THE WAY DOWN**.

2. Lower steering arm and drive truck to the location where the load is to be picked up.
3. Move the truck into position so the forks are aligned with pallet openings and the load is centered over the forks.
4. Move the truck forward and enter the pallet fully. Lift the forks to raise the pallet.

2-10. Unloading.

CAUTION Avoid spilling the load. Move slowly and use extra care when turning.

1. Drive truck carefully to area where the load is to be placed.
2. Move truck to align the load with its new position.
3. When load is in position, lower the forks to the lowest position, allowing pallet to rest on the floor.
4. Slowly move truck backward, making sure that the forks do not catch on the pallet.
5. Proceed to move the next load.

2-11. Parking

1. When finished moving loads, drive truck to its maintenance or storage area.
2. To park the truck, allow steering arm to return to its upright position which de-energizes the electrical circuits and engages the mechanical brake. Refer to Section III, Maintenance and Maintenance Parts, for mechanical brake adjustment details if the mechanical brake allows the truck to move.
3. Lower forks to their fully lowered position.
4. Charge battery as necessary. Refer to battery care instructions.

SECTION III MAINTENANCE AND MAINTENANCE PARTS

3-1. GENERAL.

This section contains information and procedures for preventive and corrective maintenance of the WRT Lift Truck. Planned maintenance includes periodic inspection, service and lubrication. Corrective maintenance includes troubleshooting, adjustment, and repair.

This section also contains parts lists and illustrations identifying maintenance parts. The callouts on each illustration correspond to the index numbers in the applicable parts list. Each parts list provides the Big Joe Manufacturing Company part number, the part description and the quantity of the part required in the assembly.

When identifying each part to be ordered, visually compare the part in the illustration with the actual part needed. To assure proper identification of each part being ordered, include your truck model number, your truck serial number (check nameplate), the part number, description, and quantity of the part(s) needed.

3-2. PART NUMBER IDENTIFICATION.

To determine the part number of a replacement part, identify the assembly in which the part is used and locate the illustration of the applicable assembly. Find the index number of the part on the illustration and refer to that index number in the parts list. If the part number is NP, order the next higher assembly. If the part number is VAR, order by part name with truck model number, capacity, and serial number.

If the part is listed with more than one part number, select the proper part number by comparing the description in the parts list with the specifications of your truck. Refer to the Data Plate to determine application to your truck.

3-3. PLANNED MAINTENANCE.

3-4. Inspection and Service.

The design of the lift truck provides a long and useful life with a minimum of maintenance. It is important to follow the operating instructions carefully and not to exceed the rated capacity of the truck. Follow the maintenance and lubrication procedures presented in this chapter to keep the equipment in top operating condition.

Table 3-1 is an inspection and service chart based on normal usage of the truck during an eight hour shift, five days per week. If the truck is used in excess of forty hours per week, the frequency of inspection and service should be increased accordingly.

INTERVAL	INSPECTION OR SERVICE	SERVICE REFERENCE
Daily	Check battery.	Paragraph 3-5.
Daily	Check Horn.	
Daily	Check operation of Belly-Button switch.	Paragraph 2-6.
Daily	Check operation of mechanical and dynamic brakes.	Paragraph 2-7.
Daily	Observe performance of truck. Investigate any improper operation. Do not operate truck if it is not functioning properly.	
Weekly	Lubricate	Paragraph 3-6.
Monthly	Check transmission oil level.	Table 3-3.
Monthly	Check seals and O-rings for oil leaks	Figure 3-6.
Monthly	Check hydraulic system oil level. Check hoses and fittings for leaks.	Table 3-3.
Monthly	Check torque value of transmission bearing retainer to insure tightness.	Paragraph 3-12d.
Monthly	Check condition of drive motor commutator, brushes, and springs.	Paragraph 3-25.
Monthly	Check condition of pump motor commutator, brushes and springs.	Paragraph 3-27.
Monthly	Check mechanical brake for proper operation. Inspect brake pads and replace if required.	Paragraph 3-11.
Monthly	Check load wheels for wear.	Paragraph 3-13.
Monthly	Check drive wheel for wear.	Paragraph 3-12.
Monthly	Inspect wiring for loose connections and damaged insulation.	
Monthly	Inspect contactor tips for excessive pitting and wear.	Paragraph 3-30.
Monthly	Check dead-man switch for proper operation.	Paragraph 3-32.
Quarterly	Check lift cylinder wiper ring and packing.	Paragraph 3-34c
Quarterly	Check for excessive jerking of steering arm when starting or stopping.	Paragraph 3-12d.

Table 3-1. Inspection and Service Chart

3-5. Battery Care.

The life of the battery can be extended by giving it good care at the proper time. Perform a daily check of the battery whether or not equipment is in daily use. Check water level, and recharge to maximum capacity immediately after use rather than waiting until the next day. Perform the following procedures at end of each day.

1. Open battery cover and remove vent caps.
2. Check specific gravity of each cell. If the average specific gravity is less than 1.250, recharge the battery.

NOTE Battery specific gravity readings should agree within ± 0.025 from cell to cell. If the variation is greater, the battery may have to be repaired or replaced.

3. Add enough distilled or filtered water to cover battery plates, but do not let electrolyte level rise higher than the base of battery filler neck.
4. Charge battery, if necessary, according to the instructions packed with battery charger.
5. When battery is properly charged, return truck to operating readiness.

3-6. Lubrication. (Figure 3-1)

Refer to table 3-2 for the recommended types of grease and oil. Table 3-3 in conjunction with figure 3-1 identifies the items requiring lubrication.

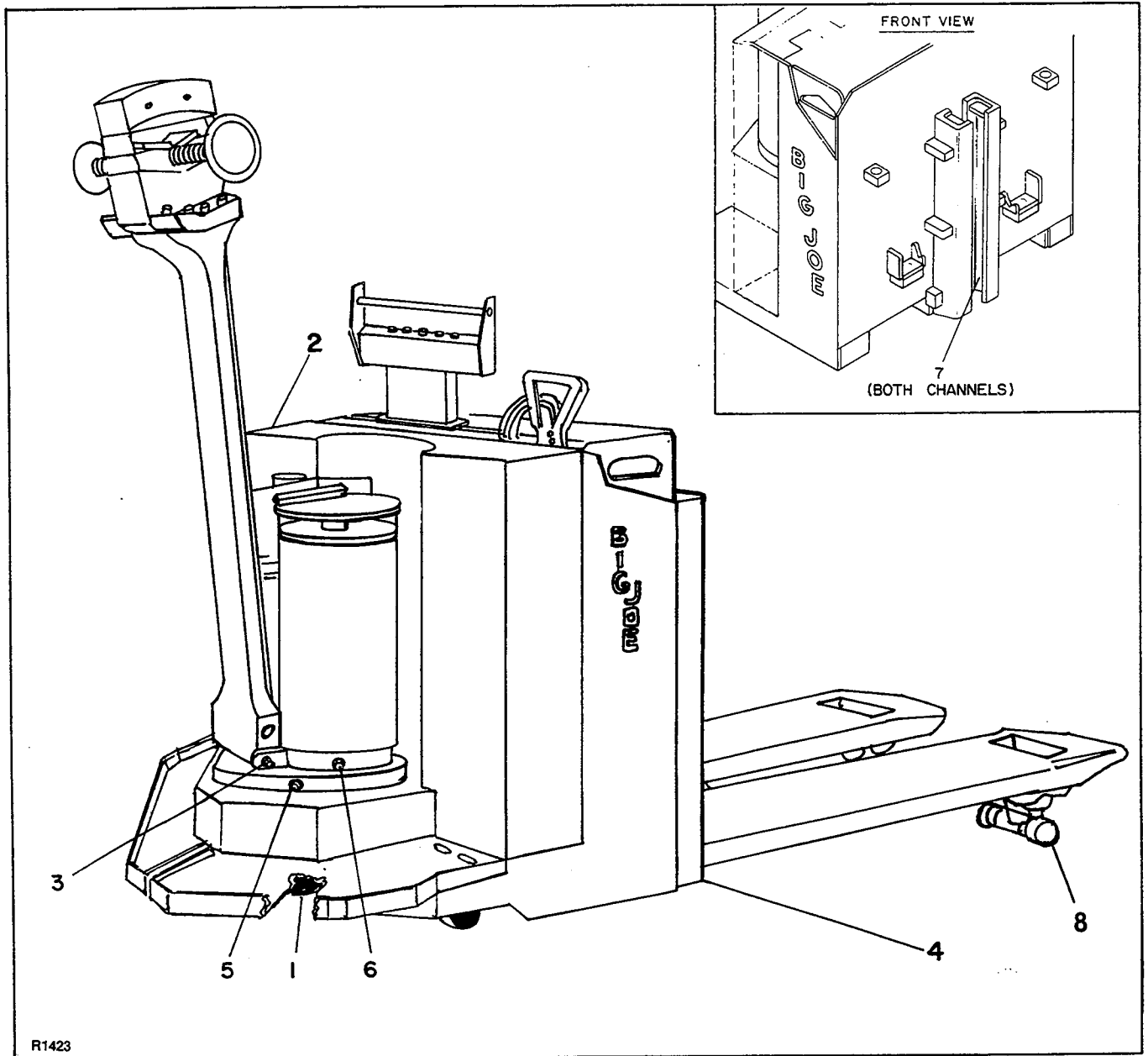

Figure 3-1. Lubrication Points

- No. 1 Transmission oil - No. 80 automotive, Part No. 055780.
- No. 2 Grease - Lithium base, general purpose.
- No. 3 Hydraulic oil - Viscosity of 150 Saybolt Universal Seconds. (In temperature below 20°F use 100 S.U.S.) oil must have foam suppressing agent, and rust and oxidation inhibitors.
- No. 4 Engine lubricating oil - No. 20.
- No. 5 Molybdenum Disulfide Grease.

Table 3-2. Recommended Lubricants (See Table 3-3)

FIG. 3-1 REF.	ITEM	METHOD OF APPLICATION	LUBRICANT (TABLE 3-2)	INTERVAL	NOTES
1	Transmission	Funnel	No. 1	Weekly	Remove plug and check level. Fill to fill line.
2	Hydraulic System	Funnel	No. 3	Weekly	Fill with hydraulic oil so that level is seen in street elbow of reservoir when forks are in lowest position.
3	Steering Arm Pivot	Can	No. 4	Weekly	1 or 2 drops.
4	Lift Mechanism	Gun	No. 2	Weekly	Grease shaft and clevis grease fittings with pressure gun
—	Drive Motor, Pump Motor, Casters	—	—	—	Bearings sealed. No lubrication required.
5	Pivot Bearing Assembly	Gun	No. 5	Weekly	Two (2) grease fittings located in outer race.
6	Transmission Pinion Assembly	Gun	No. 5	Weekly	Grease fitting located in access hole below drive motor mounting.
7	Mast Rollers and Channels	Gun	No. 2	Weekly	Remove cover over hydraulic cylinder and stick gun into two holes in top plate of channels. Grease top rollers. Raise forks to maximum height and grease lower portion of channels exposed between forks.
8	Load Wheels	Gun/Hand	No. 2	Corrosive Conditions Weekly Standard Conditions Bi-Monthly	Wheel spindles with Zerk fitting, lubricate with the gun. Wheel spindles without Zerk fitting, remove wheel nut, pull wheel and repack.

Table 3-3. Lubrication

3-7. TROUBLESHOOTING.

Table 3-4 serves as a guide to determine possible causes of trouble. The table is divided into five main categories: Truck dead; trouble with travel; trouble with braking; trouble with lifting or lowering; and miscellaneous troubles. Refer to electrical wiring diagram (figure 3-2) as a supplement to the troubleshooting chart or when tracing an electrical circuit.

MALFUNCTION	PROBABLE CAUSE	CORRECTIVE ACTION
<p>TRUCK DEAD</p> <p>Truck will not run forward or in reverse, nor will anything else operate.</p>	<p>a. 300-Amp fuse blown.</p> <p>b. Battery dead or disconnected.</p> <p>c. Defective wiring.</p> <p>d. 15-Amp control circuit fuse blown.</p>	<p>Check fuse and replace if defective.</p> <p>Check battery quick-disconnect plug. Check battery (see paragraph 3-5).</p> <p>Check for open circuit. Repair as required.</p> <p>Check fuse and replace if defective.</p>
<p>TROUBLE WITH TRAVEL</p> <p>Truck does not run forward or reverse. Everything else is normal.</p>	<p>Check all wiring. A loose connection may be the cause of malfunction.</p> <p>a. Shorted dynamic brake switch or dynamic brake solenoid.</p> <p>b. Defective dead-man brake switch.</p> <p>c. Forward or Reverse microswitch of speed control switch broken.</p>	<p>Tighten all loose connections before further troubleshooting.</p> <p>Check brake switch and solenoid and replace if defective.</p> <p>Check and replace if required.</p> <p>Check and replace switch if required.</p>
<p>Truck runs forward, but not in reverse.</p>	<p>Defective speed control switch or defective contactor.</p>	<p>Check for positive dc voltage at number 1-wire on reverse contactor. If not present when steering arm is in operating position and speed control is in reverse, speed control switch is defective. If voltage is present, contactor is defective.</p>
<p>Truck runs in reverse, but not forward.</p>	<p>Defective speed control switch or defective contactor.</p>	<p>Check for positive dc voltage at number 2-wire on forward contactor. If not present when steering arm is in operating position and speed control is in forward, speed control switch is defective. If voltage is present, contactor is defective.</p>

Table 3-4. Troubleshooting Chart

MALFUNCTION	PROBABLE CAUSE	CORRECTIVE ACTION
Truck runs forward and in reverse at slow speed; will not run at higher speeds.	Defective second and/or third speed contactors.	Check coils for continuity. Check contacts for excessive wear. (A black appearance where tips make contact is normal.) Repair or replace as required.
Oil splashes out of vent when lowering forks.	Oil level too high.	Drain, then refill reservoir when forks are in their lowest position.
Squealing sounds when forks are raised.	<ul style="list-style-type: none"> a. Oil level too low. b. Aerated oil (foamy). c. Defective bearing in pump motor or pump. 	<ul style="list-style-type: none"> Add oil to reservoir. Drain and replace oil. Replace bearing or pump.
Forks do not lift to top.	Oil level too low.	Add oil to reservoir.
No motion, slow or jerky action of hydraulic system.	<ul style="list-style-type: none"> a. Load heavier than capacity. b. Defective lift cylinders. c. Defective pump. d. Low battery charge. 	<ul style="list-style-type: none"> Refer to data plate for maximum lift capacity. Rebuild or replace. Check and repair or replace if necessary. Recharge battery.
MISCELLANEOUS		
Steering arm does not return to the upright position.	<ul style="list-style-type: none"> a. Return spring improperly adjusted. b. Binding brake linkage or electrical cable. 	<ul style="list-style-type: none"> Readjust spring tension (see paragraph 3-9). Check and free the binding item.
Truck moves forward when arm is pulled down.	<ul style="list-style-type: none"> a. Belly-button switch defective. b. Short in control head. 	<ul style="list-style-type: none"> Check for short, and repair or replace as necessary. Check wiring and repair as required.
Steering arm jerks excessively when starting or stopping the truck.	<ul style="list-style-type: none"> a. Worn steering arm pivot bearings. b. Drive wheel tire worn. c. Brake is dragging. d. Excessive play in transmission pivot bearing. 	<ul style="list-style-type: none"> Replace bearings. Replace drive wheel. Adjust brake. See paragraph 3-11. Adjust bearing. See paragraph 3-12.
Truck runs forward and in reverse at second or third speed only. Truck does not move when control is in first speed position. Everything else is normal.	Defective or open speed control resistor.	Check for clean, tight connection. Check resistor for continuity and replace or repair as required.

Table 3-4. Troubleshooting Chart (Cont.)

MALFUNCTION	PROBABLE CAUSE	CORRECTIVE ACTION
<p>Mechanical brake grabs when steering arm is in operating position.</p> <p>TROUBLE WITH LIFTING OR LOWERING</p> <p>Forks do not rise; everything else is normal.</p> <p>Forks do not lower; everything else is normal.</p> <p>Forks creep downward under load; everything else is normal.</p> <p>Oil sprays or flows from top of the lift cylinder.</p>	<p>Brake linkage overadjusted.</p> <p>a. Defect in electrical system.</p> <p>b. Defect in hydraulic system.</p> <p>Defect in hydraulic system.</p> <p>Leak in hydraulic system.</p> <p>Defective seal in lift cylinder.</p>	<p>Adjust mechanical brake (see paragraph 3-11).</p> <p>Check hydraulic oil level. Before further troubleshooting, fill hydraulic reservoir so that oil is seen in street elbow when forks are fully lowered. Tighten all electrical connections.</p> <p>If pump motor does not run when lift button is depressed, defect is in pump solenoid or pump motor. Check for positive dc voltage at pump motor to locate defect. Repair or replace defective part.</p> <p>Check that wiring harness is properly connected to lift switch. Secure all connections.</p> <p>Check lift switch. Replace if defective.</p> <p>Check for pinched hoses. Check pump for proper operation. Replace if necessary. Check for defect in lift cylinder.</p> <p>Look for obstruction in the hydraulic line. Check lower switch for proper action. Check lowering solenoid valve on pump. Repair as required.</p> <p>Look for loose fittings in the hydraulic line. Check solenoid-operated lowering valve for obstructions. Check pump for leakage back into the reservoir. Repair fittings or replace pump as required.</p> <p>Overhaul the lift cylinder and install new seal, O-rings, and wiper ring.</p>

Table 3-4. Troubleshooting Chart (Cont.)

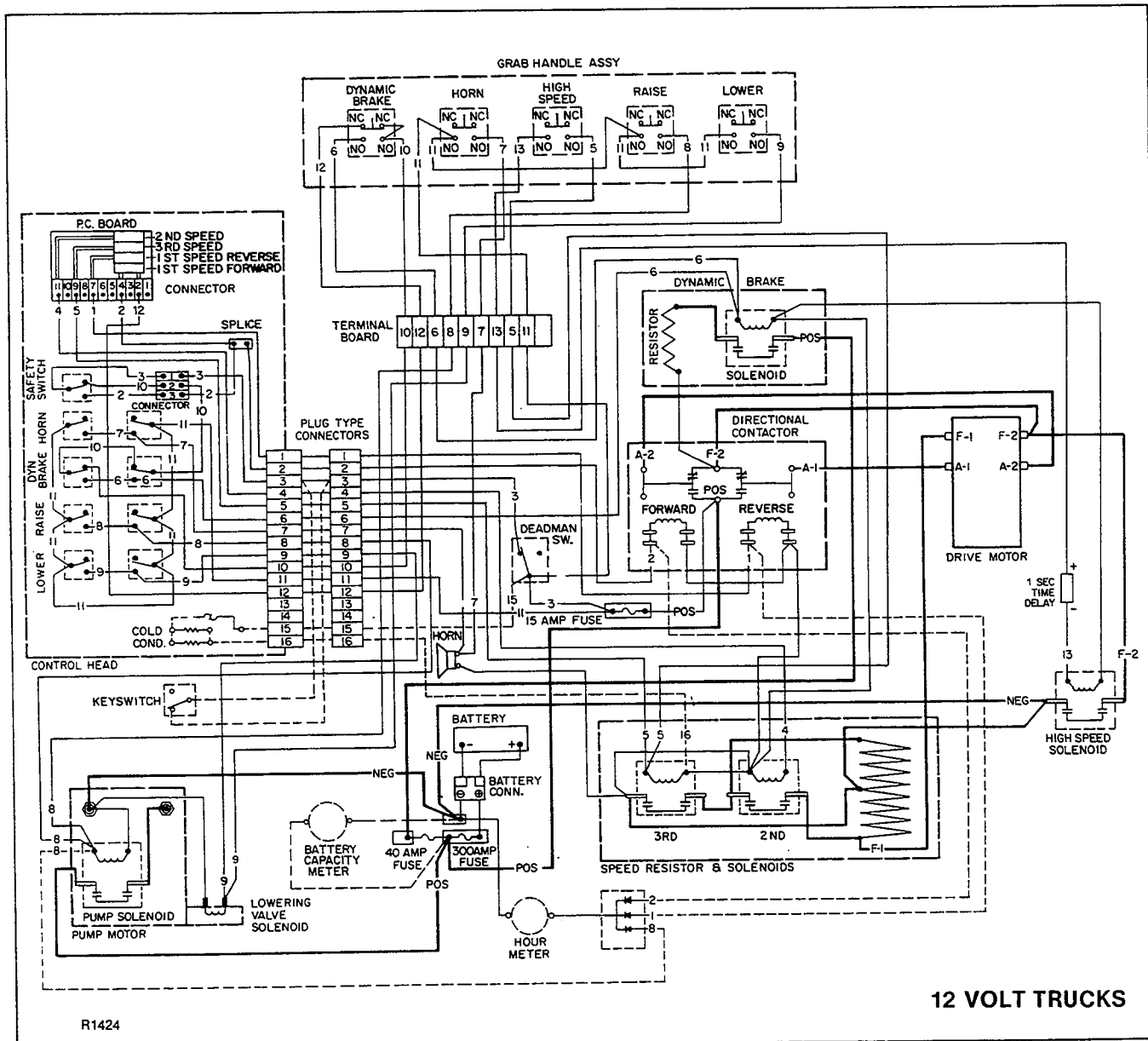
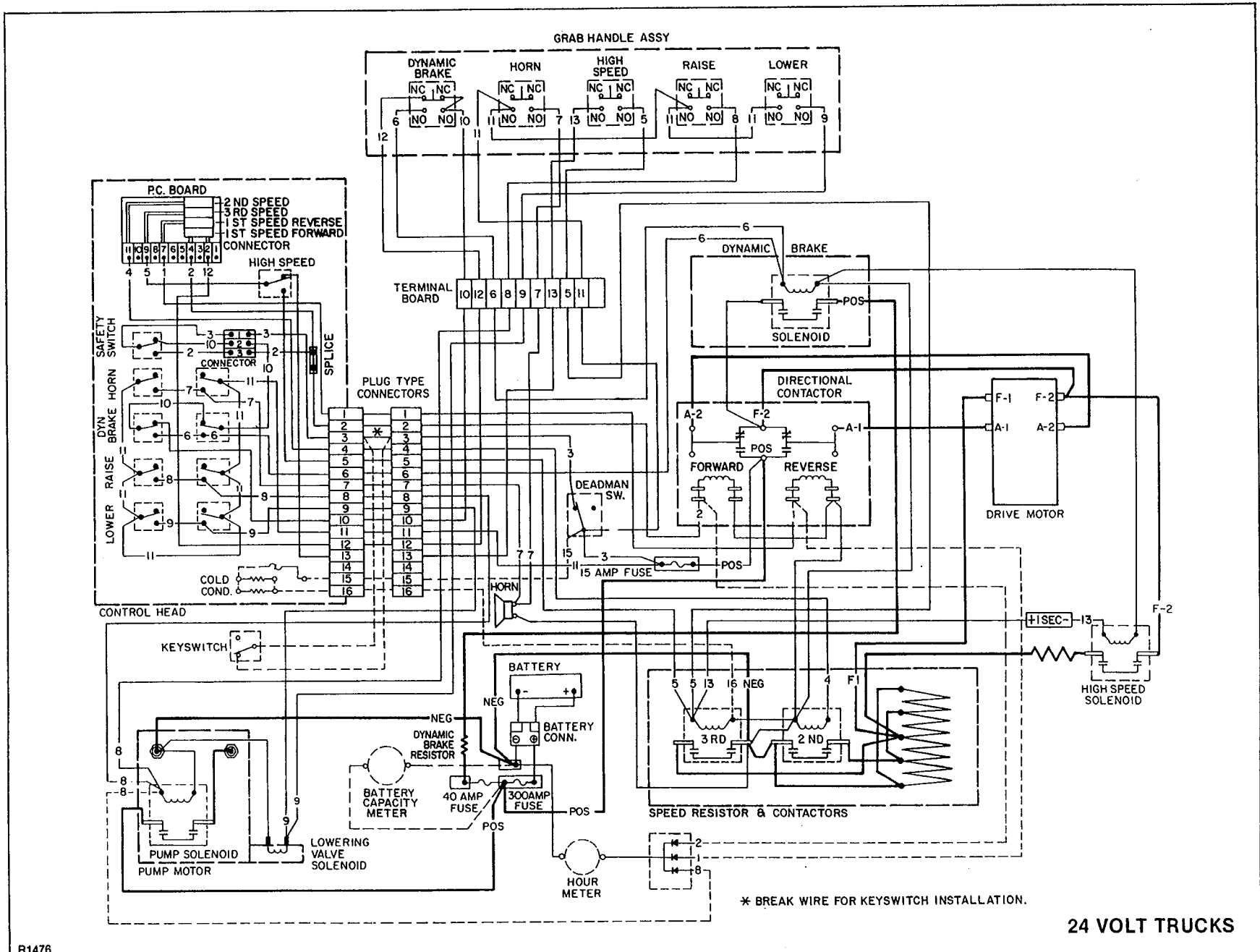

Figure 3-2. Wiring Diagram 12 Volt Trucks (Sheet 1 of 2)



R1476

Figure 3-2. Wiring Diagram 24 Volt Trucks (Sheet 2 of 2)

24 VOLT TRUCKS

3-8. ADJUSTMENT AND REPAIR.

The following procedures cover adjustments, part or assembly replacement, and repair of assemblies. The replacement procedures include reassembly where procedures are not obvious from the disassembly procedures. The procedures are independent of each other unless specifically referenced.

3-9. Steering Arm. (Figure 3-3)

a. Steering Arm Return Spring Adjustment.

The tension on the steering arm return spring should allow the arm to return gently to its upright position. Excessive tension will cause the arm to snap up and may cause damage to the electrical cable, brake linkage, or the spring itself. If the steering arm does not return fully, check for binding in the brake linkage or wiring harness before making any adjustments. If they do not bind, refer to figure 3-3 and proceed as follows to adjust the steering arm return spring tension.

1. Lower the control head assembly until it is 29.25 inches from the floor as measured from the center of the rubber handle on the control head.
2. Butt the stop-adjustment (22) against the control handle (3) and lock into place with 3/8 inch bolts (25).

NOTE The steering arm return spring torque is adjustable by means of rotating the handle shaft (15). The handle shaft end is 1/2-inch square and is accessible on the left side of the steering arm.

3. Fit a torque wrench with a 1/2-inch socket over the exposed left end of the handle shaft (15).
4. Place the control handle (3) in vertical position, and torque handle shaft from 52 to 54 foot/pounds.

CAUTION Excessive torque on the handle shaft (15) will cause overstress on the return spring (19). If the handle does not return to upright position properly at this amount of torque, the assembly should be checked for interference.

b. Steering Arm Return Spring Replacement.

When replacing the return spring, begin with the steering arm in the upright position.

1. Disconnect battery.
2. Remove service cover (2, figure 3-10) by removing three flathead screws (3).

CAUTION The steering arm has a tendency to fall downward when the tension on the return spring is released.

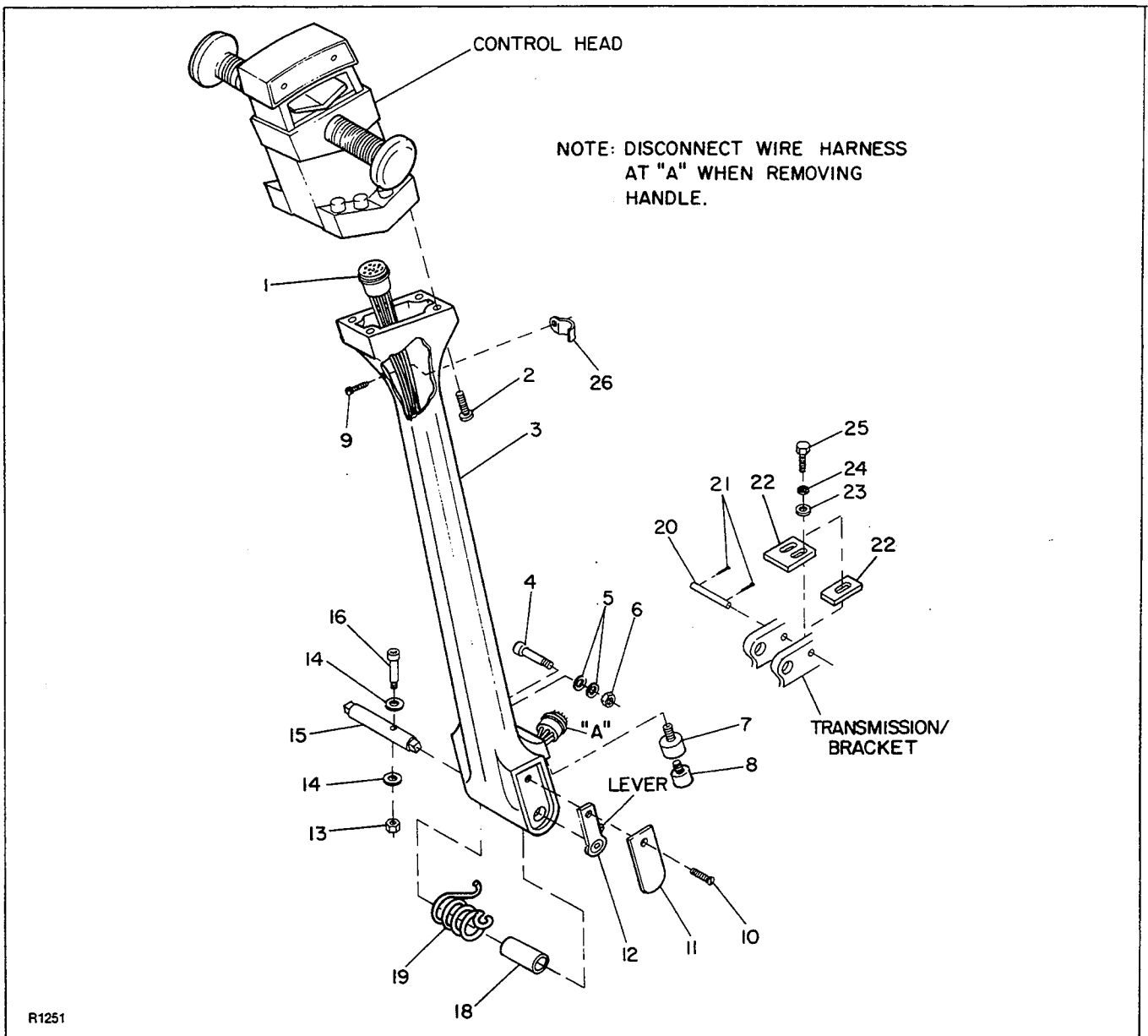

Figure 3-3. Steering Arm

INDEX NO.	PART NO.	PART NAME	NO. REQD.
1	023084	Wire Harness Assembly	1
2	065481	Screw, Socket Hd. Cap, 1/4-20 UNC X 1	4
3	800243	Control Handle	1
4	052772-02	Shoulder Bolt, 1-1/2 Lg.	REF
5	077024	Washer, Bottom 3/8	REF
6	059625	Nut, Self-Locking, 1/4-20 UNC	REF
7	401467	Stop, Bumper	2
8	053038	Bumper, Rubber	2
9	069478	Screw, Mach, Flt. Ph. 1/4-20 x 3/4	1
10	069481	Flat Hd., 1/4-20 UNC x 1-1/4	1
11	401474	Cover, Ratchet	1
12	800242	Handle Ratchet	1
13	059630	Locknut, 10-24 UNC 3B, Plated	1
14	077119	Washer, 1/4 Flat	2

Δ Used on trucks serial number 309021 and lower

INDEX NO.	PART NO.	PART NAME	NO. REQD.
15	401529	Handle Shaft	1
16	052773-01	Bolt, Shoulder	1
17	---	Not Used	
18	401455	Sleeve, Pivot Pin	1
19	075083	Spring, Handle Return	1
20	401470	Pin, Spring	1
20	402070 *	Pin-Spring	1
21	060417	Pin, Cotter, 3/32 x 3/4	2
22	401468 Δ	Arm Stop, Adjustable	REF
22	402068 *	Bracket	1
23	077056	Washer, 7/16	REF
24	077211	Lock Washer, 3/8, Split	REF
25	063603	Screw, Hex. Cap, 3/8-16 x 3/4	REF
25	063602 *	Bolt, Hex Hd. 3/8-16 x 5/8	REF
26	502474	Clamp, Wire, Speed Nut Assembly	1

* Used on truck serial number 309022 and higher

3. Hold steering arm in upright position, making sure the arm cannot fall.
4. Remove screw (10, figure 3-3) and handle ratchet cover (11).
5. Fit a 1/2-inch wrench (socket-type preferred) on the exposed left end of the handle shaft (15).

WARNING The steering arm return spring will rapidly rotate the handle shaft and any attached tools approximately 180° if the ratchet lever suddenly is released. Make sure the movement is kept under control.

6. Actuate the lever protruding from the handle ratchet (12) and allow the handle shaft to rotate slowly counterclockwise until spring tension has been released.

NOTE At this time, the steering arm should be swung down and supported. Bumper stops (7) may be removed to allow more room to perform the following steps.

7. Remove bumper stops (7) and disconnect wire harness.
8. Lift out the handle ratchet (12).
9. Extract screw (16), washers (14) and locknut (13) that attaches the end of the spring (19) to the handle shaft (15).

CAUTION The steering arm may fall from the truck when the handle shaft is removed. Make sure support for the steering arm is adequate and secure before proceeding.

10. Drive the handle shaft out of the steering arm through the side hole, and remove sleeve (18).
11. Remove two cotter pins (21) from spring pin (20) and remove spring pin from the transmission.
12. Remove the steering arm return spring (19).
13. Reinstall the handle shaft and sleeve while placing a new steering arm return spring in the position formerly occupied by the old spring.
14. Rotate the handle shaft (15) until the small hole lines up with the hooked end of the steering arm return spring (19).
15. Reinstall the screw (16), washers (14) and locknut (13) in the steering arm return spring hooked end and into the handle shaft hole.
16. Reinstall spring pin (20) and cotter pins (21), and hook end of spring on pin.
17. Reinstall the handle ratchet (12) removed in step 8.
18. Reinstall bumper stops (7) if removed.
19. Position the handle ratchet lever to allow clockwise movement (viewed from steering arm left side), and adjust the steering arm return spring tension as described in paragraph 3-9a.

c. Handle Stop Adjustment.

To avoid unnecessary strains on the brake linkage, the adjustment stop (22, figure 3-3) should halt steering arm downward movement. The adjustment stop can be moved back and forth, and set to absorb the shock of steering arm over-travel.

1. Remove service cover (refer to 2, figure 3-10).
2. Refer to paragraph 3-9a and perform steps 1 and 2.
3. Reinstall the service cover.

3-10. Grab Handle Replacement. (Figure 3-4)

The handle may be replaced if accidentally damaged using the following procedure.

1. Disconnect battery.
2. Remove the switch box cover (6) by removing four screws (5).
3. Unscrew the five locknuts (8) and remove the five pushbuttons, the bezels (7) and spacer (11).
4. Remove two screws (18), nuts (17), and bar (19), and slide the grab handle assembly over the wiring harness.

NOTE Replace grab handle assembly by performing steps 1 through 4 in reverse.

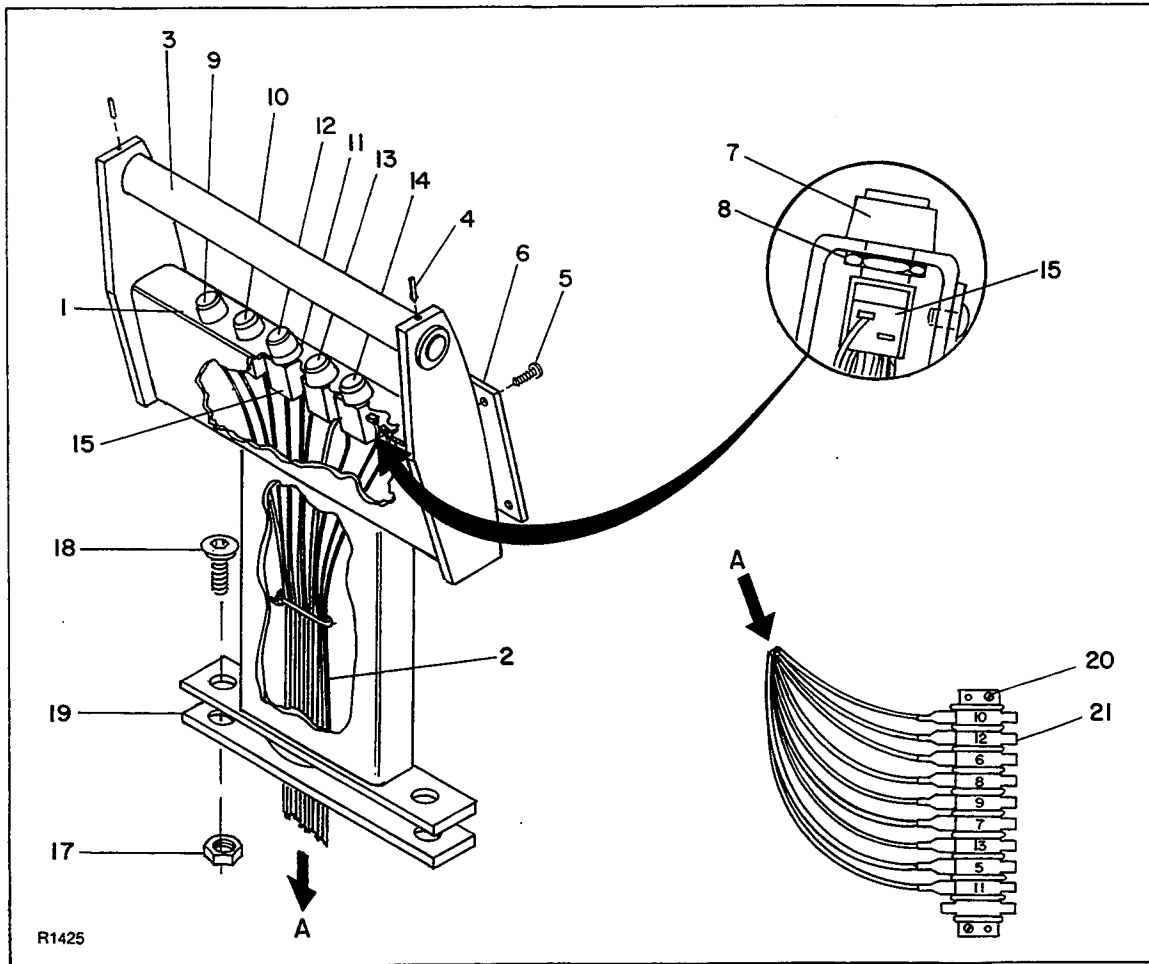

R1425

Figure 3-4. Grab Handle Assembly

INDEX NO.	PART NO.	PART NAME	NO. REQD.
	503970	Grab Handle Assembly	1
1	503968	Weldment, Handle	1
2	023093	Wire Harness	1
3	401594	Tube Handle	1
4	060970	Roll Pin	2
5	071376	Screw, Ph. Mach. Truss 10-32 X1/2	4
6	401597	Cover, Switch Box	1
7	023087	Bezel	5
8	---	Locknut (Part of switch	5
9	056584	Pushbutton, Brake	1
10	056583	Pushbutton, Horn	1

INDEX NO.	PART NO.	PART NAME	NO. REQD.
11	077054	Spacer	1
12	056597	Pushbutton, High Speed	1
13	056581	Pushbutton, Raise	1
14	056582	Pushbutton, Lower	1
15	023095	Switch, Momentary With Nut	5
16	052895	Plunger, Switch	5
17	059429	Nut	2
18	069713	Screw-Sock. Flt. Hd.	2
19	401547	Bar	1
20	068231	Screw	2
21	021227	Block, Terminal	1

3-11. Disc Brake.

a. Disc Brake Adjustment. (Figure 3-5)

1. Disconnect battery.
2. Remove service cover (refer to 2, figure 3-10).
3. With the steering arm in the vertical position, turn brake disc by hand (3, figure 3-6). If brake disc rotates, tighten locknuts (figure 3-5) until brake disc is secure and will not rotate. Lower handle to operating position (refer to figure 3-5) and brake disc should rotate freely.
4. Lower steering arm to lowest position and repeat procedures in step 3, adjusting locknuts on opposite end of brake rod (refer to figures 3-5 and 3-6).
5. Reinstall service cover and reconnect battery to return truck to service.

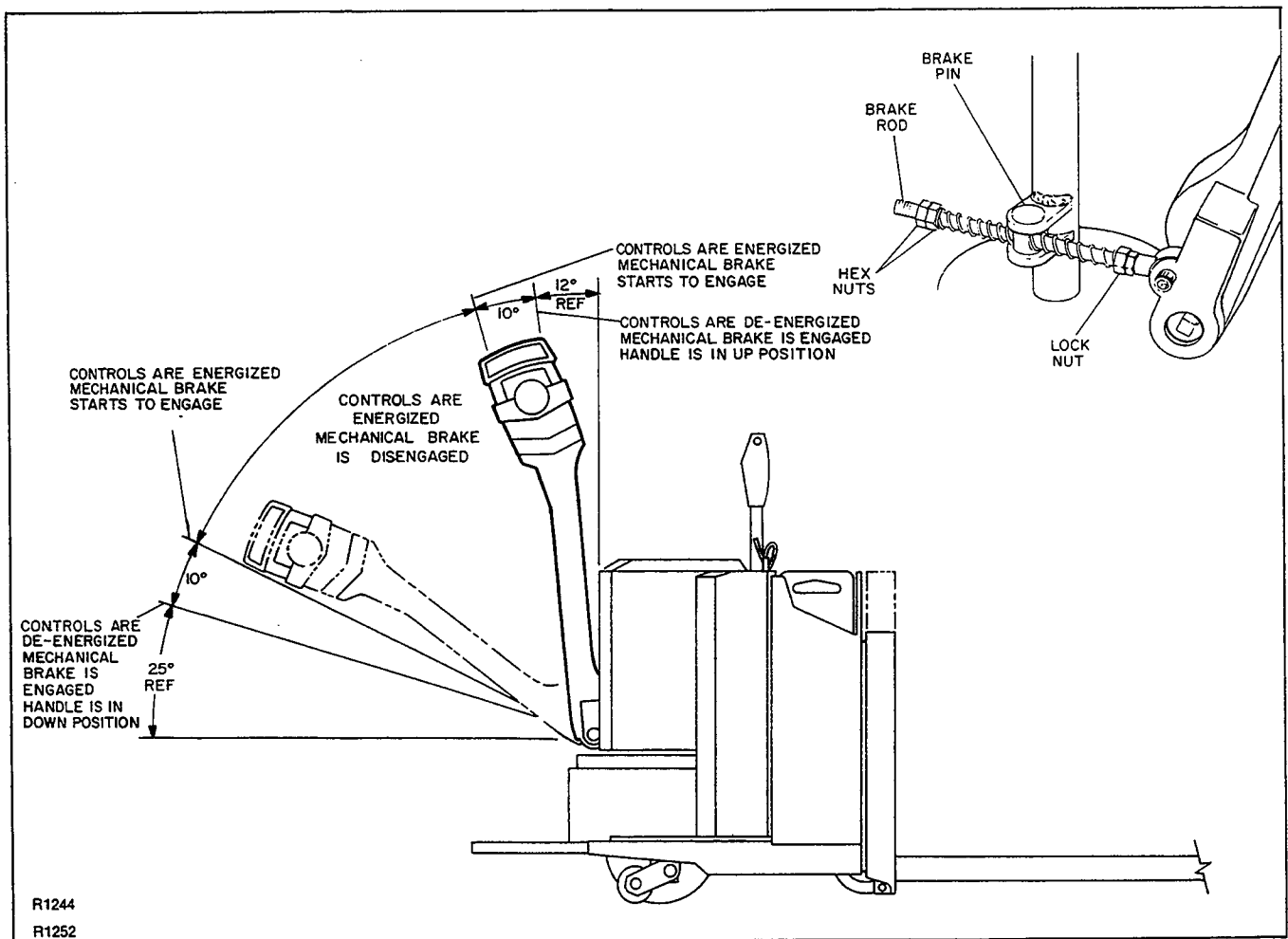

Figure 3-5. Mechanical Brake Adjustment

b. Replacement of Disc Brake Parts. (Figure 3-6)

1. Disconnect battery.
2. Block the wheels to prevent the truck from moving.
3. Remove service cover.
4. Remove shoulder bolt (33) from rod end (14) of control handle to disassemble brake.
5. Remove shoulder bolt (24) from brake link (22) and brake lever arm.
6. Remove two bolts and nuts on brake caliper assembly (25) to release brake pads.
7. Insert replacement brake pads in clamp assembly, one pad on each side of disc with linings toward the disc, and secure pads and clamp with two bolts and nuts.

NOTE Brake disc should be centered between new brake pads. Shims (7) and (9) are available in three thicknesses and may be added or deleted as necessary.

8. Check clearance between brake pads and brake disc and obtain sufficient shims to center the brake disc between the brake pads.
9. If brake disc is closer to one brake pad than the others, perform the following steps to adjust the clearance.
 - (a) Remove nut (1) and washer (2).
 - (b) Remove bolts and nuts installed in step 6.
 - (c) Lift brake disc (3), key (4), and shim (7) off motor shaft.
 - (d) Add to or remove existing shims (7) or (9) as necessary.
 - (e) Reinstall brake disc (3), key (4), washer (2), and nut (1).
 - (f) Install bolts and nuts removed in step 9(b) and check clearance between brake disc and brake pads by rotating disc by hand. Repeat steps 8 and 9 if clearance is incorrect.

CAUTION Overtightening of nuts on brake caliper assembly will restrict movement of brake pads and impair brake performance. Both upper and lower brake pads must move freely toward brake disc to engage brake properly.

10. Install shoulder bolt (24) in brake link (22) and brake lever arm. Reinstall rod end (14) in control handle and reassemble with shoulder bolt (33).
11. Release steering arm.
12. Refer to paragraph 3-11a and adjust brake.

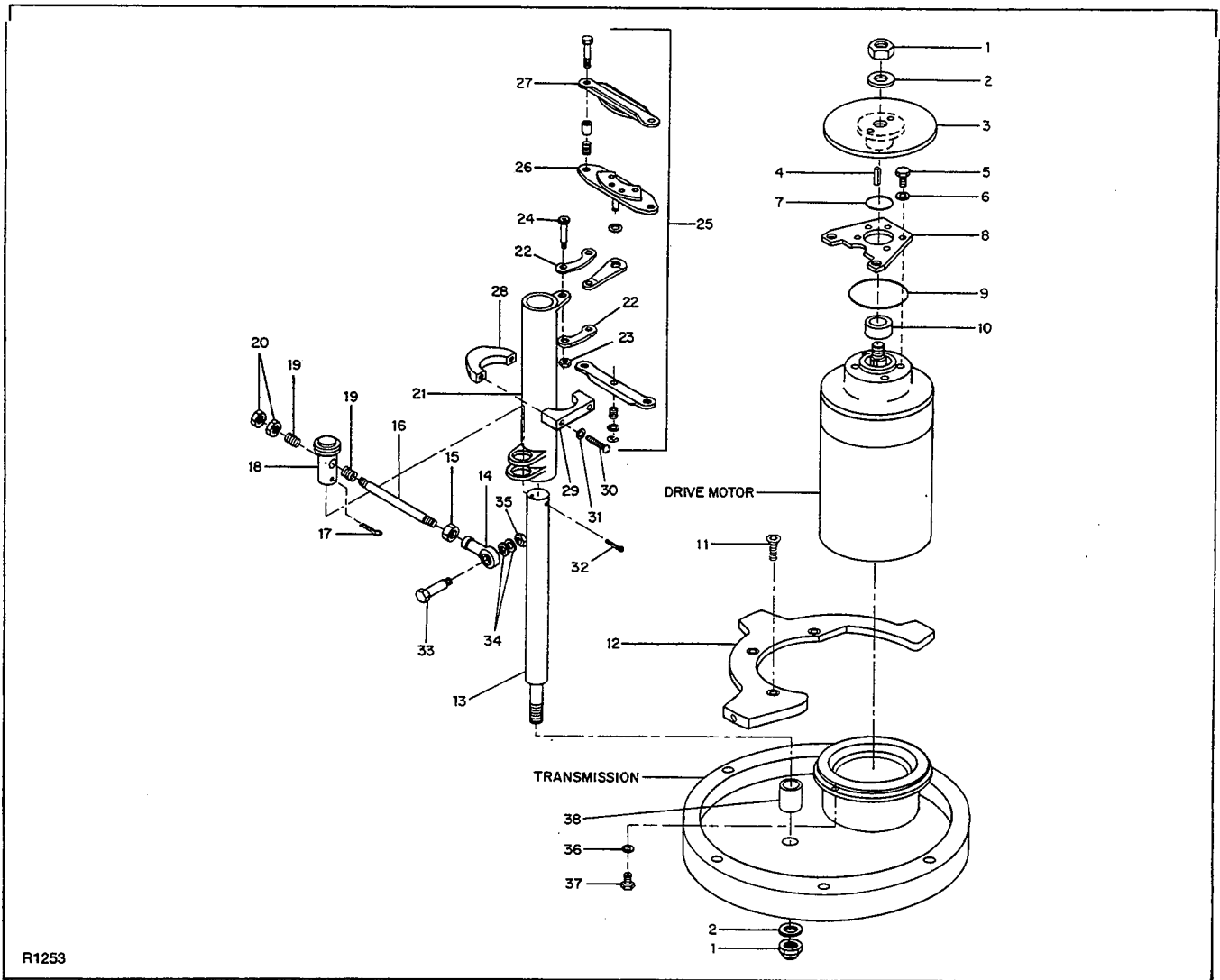

R1253

Figure 3-6. Disc Brake and Linkage

INDEX NO.	PART NO.	PART NAME	NO. REQD.	INDEX NO.	PART NO.	PART NAME	NO. REQD.
1	059645	Locknut, 5/8-18	2	19	075082	Brake Spring	2
2	077096	Washer, 5/8 ID	2	20	059427	Nut, Hex., 5/16-24	2
3	052892	Brake Disc Assembly	1	21	503949	Brake Tube Weldment	1
4	057900-01	Key, 1/4 X 1/4 X 3/4	1	22	058358	Brake Link	2
5	063553	Screw, Hex. Cap, 5/16-18 X 3/4	5	23	059625	Locknut, 1/4-20	2
6	077210	Lock Washer, 5/16 Split	5	24	052772-01	Shoulder Bolt, 5/16 Dia x 5/8 Lg.	2
7	074328-01	Shim, 0.010 (Brown)	A/R	25	052880	Brake Caliper Assembly	1
7	074328-02	Shim, 0.020 (Pink)	A/R	26	900561	Brake Pad, Rib Side	1
7	074328-03	Shim, 0.030 (Coral)	A/R	27	900560	Brake Pad, Cam Side	1
8	061322	Brake Mounting Plate	1	28	401466	Cam, Dead-man	1
9	074327-01	Shim, 0.015 (Pink)	A/R	29	056132	Clamp	1
9	074327-02	Shim, 0.030 (Coral)	A/R	30	071380	Screw, Mach, Ph Tr #10-32 UNF X 1-1/2	2
10	401577	Spacer, Disc	1	31	077208	Washer, Lock Split #10	2
11	069713	Screw, Socket Hd., 3/8-16 X 1-1/4	3	32	060448	Cotter Pin	1
12	401487	Motor Cover Mounting Rim	1	33	052772-02	Shoulder Bolt	1
13	401396	Shaft, Brake Pivot	1	34	077024	Washer	2
14	062353	Rod End	1	35	059625	Locknut, 1/4-20	1
15	059627	Locknut, 5/16-24	1	36	077117-02	Washer, Lock 1/4	5
16	062352	Brake Rod	1	37	065480	Screw, Socket Hd 1/4-20X1	5
17	060425	Cotter Pin, 1/8 X 1	1	38	402063	Spacer	1
18	055185	Brake Pin	1				

3-12. Transmission And Drive Wheel Repair.

a. Transmission Removal and Disassembly. (Figure 3-7)

Removal and disassembly of the transmission facilitates inspection and replacement of parts.

1. Disconnect battery.
2. Securely block load wheels so truck cannot move, and remove service cover (2, figure 3-10).
3. Make sure the cables between the battery disconnect plug and the electrical control panel are labeled according to their destinations before they are disconnected.
4. Label the wire connecting the 40-ampere fuse to the dynamic brake and disconnect.
5. Label the wires that lead to the pump and lowering valve solenoids and disconnect.
6. Remove access cover (20, figure 3-10) directly behind the drive wheel by removing the four flat socket head screws.
7. Remove the four screws (17, figure 3-10), lock washers (18) and cable guard weldment (16).
8. Remove the six hex head screws and lock washer that secure the outer bearing race (22, figure 3-7).

NOTE Eye bolts may be installed in the four 1/2-13 tapped holes on the top surface of outer bearing race (22) to lift the complete transmission from the frame.

CAUTION The transmission may snag on adjacent electrical cables during the lifting operation. Hoist the transmission slowly and check that it clears all nearby parts.

9. Lift transmission from frame and place in a vertical position for inspection or repair by either putting blocks under pivot bearing or placing on a holding frame.
10. Make sure the four cables to the drive motor are properly labeled A1, A2, F1, and F2; then disconnect the cables from the drive motor.
11. Remove the hex head cap screw and lock washer that hold the wiring harness and its mounting bracket to the transmission.
12. Remove the four hex head cap screws and lock washers that secure the electrical control panel, and lift off the control panel.
13. Disconnect the mechanical brake by removing the shoulder bolt (24, figure 3-6) and lock nut (23) that secure the brake caliper (25) to the links (22).

14. Remove drain plugs (27, figure 3-7) and drain the transmission oil into a suitable container.
15. Remove the five socket head cap screws (54) and lock washers (55) and lift out the motor, making sure the splined coupling (53) is not misplaced. Lay motor and brake parts aside until reassembly.
16. Remove eight screws (25), transmission cover (23) and gasket (51).
17. Remove eight screws (47) and lock washers (48) and pull off drive wheel.

NOTE Observe the torque requirements listed in table 3-5 when reassembling the transmission.

b. Spiral Bevel Pinion Gear Replacement.

1. Remove and disassemble the transmission, as discussed in paragraph 3-12a.
2. Remove the four socket head screws (4, figure 3-7) and lock washers (5) and remove bearing cap and oil seal.

NOTE Shim (50) may be lost during disassembly unless special care is taken.

3. Remove spiral bevel pinion assembly and attached parts, making sure to retain shim (50) for use during reassembly.
4. Remove roll pin (7) from bearing locknut (6), this action permitting complete disassembly.

NOTE If spiral bevel pinion (12) requires replacement, the spiral bevel gear (28) also will require replacement. *They must be replaced as a matched set.*

5. Reassemble the spiral bevel pinion gear assembly in the reverse order of disassembly with the following instructions.
 - (a) Pregrease the upper and lower bearing cones (11) with molybdenum disulfide grease, and place shim into bore first then spiral bevel pinion assembly.
 - (b) Make sure the spacer shield (39) is installed with the chamfer side down, facing the back face of the spiral pinion.
 - (c) Tighten the bearing locknut (6) to seven inch/pounds torque before locking in place with roll pin (7).

(d) After reassembly the spiral bevel gear must turn freely. If there is a binding, spiral bevel gear (28) must be removed by removing roll pin from locknut and shims added until gear rotates freely. If there is excessive backlash then the shim must be reduced until the gear rotates freely. Reassemble locknut and tighten to a torque value of twelve (12) inch/pounds. Reinstall 3/16 inch roll pin into aligning holes.

c. Spur Pinion, Internal Gear and Bearing Set Replacement.

To replace a spur pinion, internal gear or bearing set proceed as follows: (Fig. 3-7)

1. Remove adjustable clamp and transmission seal (37, 38)

NOTE Use care in removing seal so as not to damage material sealing lip.

2. Remove 3/16" roll pin, bearing locknut, spiral bevel gear (28) and shim.
3. Remove four 3/8-16 hex head cap screws and bearing retainer (30).
4. Remove bearing retainer with "O" ring (46) to remove bearing locknut (44) locking tab on bearing lockwasher must be bent outward to allow locknut to be removed.
5. Remove internal spur gear (40) and wheel load bearings. Spur pinion (33) and bearings cannot be removed by applying pressure from wheel hub side. When reassembling, spiral bevel gear (28) must rotate freely with spiral bevel pinion and shims will have to be added or deducted (29) to accomplish this. Reassemble locknut and tighten to a torque value of twelve (12) inch/pounds torque. Reinstall 3/16" roll pin into aligning holes.

After re-assembling internal gear assembly (40) locknut (44) must be tightened to set the end play at zero (0) to .005 end play. Then locking tab on lockwasher (45) bent down into notch on locknut (44) to keep it from rotating loose. Reinstall bearing retainer and "O" ring. Light coating of petroleum jelly should be applied to "O" ring for ease of assembly.

Replace transmission seal and clamp (37, 38) on main housing. The clamp should be tightened only enough to keep seal from rotating on main housing. It is possible with too much torque on locking screw to strip the notched area of clamp.

d. Transmission Pivot Bearing Adjustment. (Figure 3-7)

NOTE A special spanner wrench for setting bearing preload may be obtained from Big Joe parts and service department. Wrench part number is 900880.

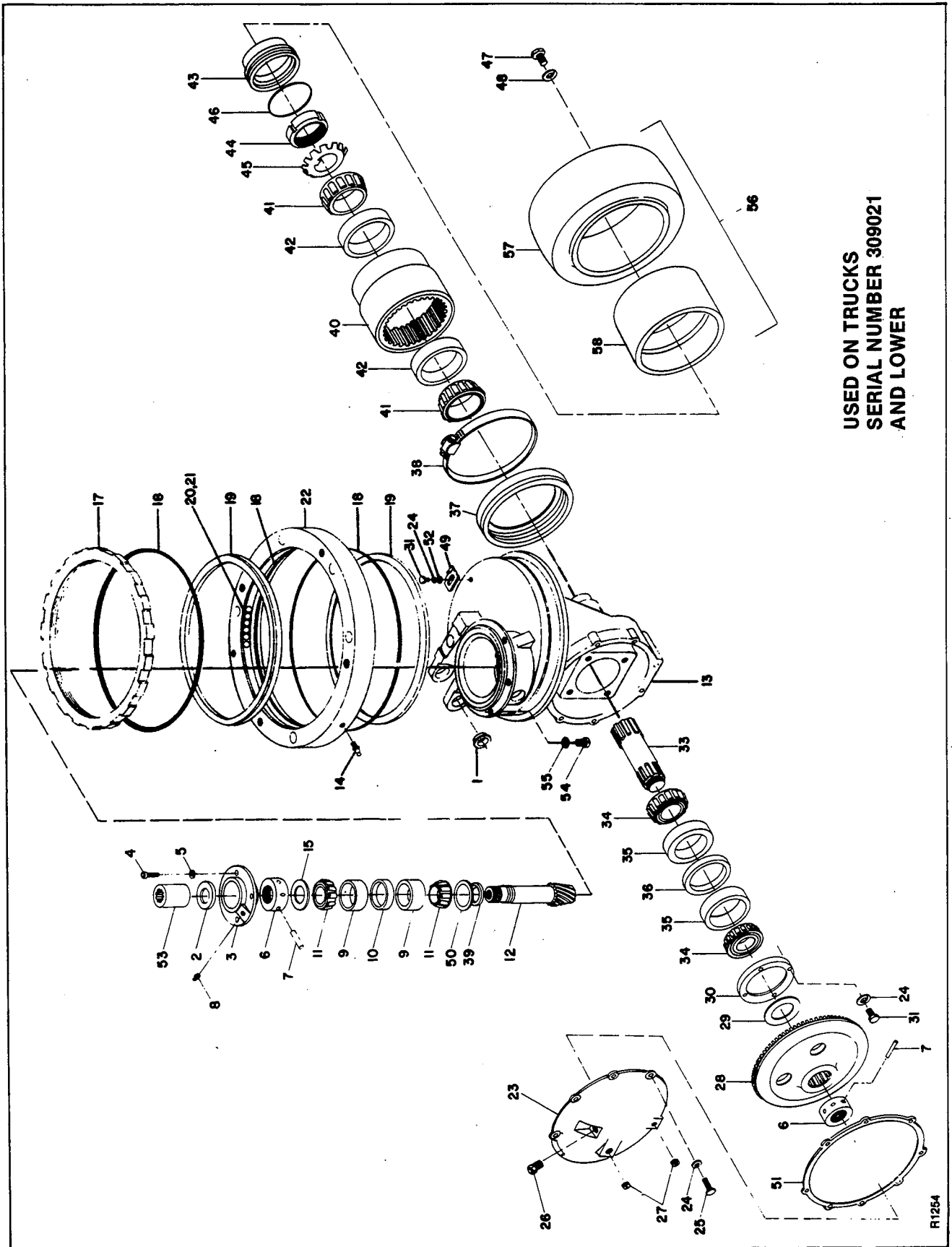

USED ON TRUCKS
 SERIAL NUMBER 309021
 AND LOWER

Figure 3-7. Transmission and Drive Wheel (Sheet 1 of 2)

R1254

INDEX NO.	PART NO.	PART NAME	NO. REQD.	INDEX NO.	PART NO.	PART NAME	NO. REQD.
1	504021-01	Transmission Assembly	1	30	401392	Bearing Retainer	1
1	053040-01	Flanged Bearing	2	31	064605	Screw, Hex. Cap, 3/8-16 UNC x 1	4
1	053041-01**	Flanged Bearing	2	32	---	Not Used	---
2	043129	Oil Seal	1	33	057269	Spur, Pinion	1
3	800237	Bearing Cap	1	34	051229	Cone, Bearing	2
4	065555	Screw, Socket Hd., 5/16-18 UNC x 1	4	35	051228	Cup, Bearing	2
5	077117-01	Lock Washer, Hi-Collar, 5/16	4	36	075080	Spacer, Bearing Cup	1
6	059548	Locknut, Bearing	4	37	073519	Seal, Special Transmission	1
7	060977	Roll Pin, 3/16 x 1-3/4	2	38	056134	Clamp, Adjustable	1
8	025705	Grease Fitting	2	39	075079	Spacer, Shield	1
9	051227	Cup, Bearing	1	40	057270	Internal Spur Gear	1
10	075078	Spacer, Bearing Cup	2	41	051231	Cone, Bearing	2
11	051226	Cone, Bearing	1	42	051230	Cup, Bearing	2
12	057264	Pinion, Spiral Bevel	1	43	800241	Bearing Retainer	1
13	800236	Main Housing, Transmission	1	44	059682	Locknut, Bearing	1
14	025704	Grease Fitting	2	45	077597	Lock Washer, Bearing	1
15	077118	Washer, Flat 1-1/8	1	46	042116	O-ring, 3.5 ID	1
16	---	Not Used	---	47	064711	Screw, Hex. Cap, 1/2-13 UNC x 1-3/4	---
17	800239	Bearing Retainer	1	48	077213	Lock Washer, 1/2 Split	8
18	057189	Felt Strip	A/R	49	401473	Retaining Clip	8
19	055183	Raceway, Bearing	1	50	074324	Shim Pack	1
20	051232	Ball, 7/16 Dia., Plain	43	51	057514	Gasket, Cover	A/R
21	051233	Ball, 27/64 Dia., Blk. Oxide	43	52	077056	Washer, Flat 7/16	1
22	401393	Outer Bearing Race	1	53	057268	Splined Coupling	1
23	800238	Cover, Transmission	1	54	065480	Screw, Socket Hd. Cap, 1/4-20 UNC x 1	1
24	077211	Lock Washer, 3/8	13	55	077117-02	Lockwasher, 1/4 Hi Collar	---
25	064607	Screw, Hex., Cap, 3/8-16 UNC x 1-1/4	8	56	503936 *	Drive Wheel Assembly	5
26	076701	Breather	1	57	502281	Wheel, Rubber	1
27	026310	Plug, Socket Hex., 3/8 NPT	2	58	502280	Wheel, Poly	1
28	057266	Gear, Spiral Bevel	1		800256	Hub	1
29	074321-01	Shim, 0.020 (Yellow)	A/R				
29	074321-02	Shim, 0.010 (Brown)	A/R				
29	074321-03	Shim, 0.004 (Tan)	A/R				
29	074321-04	Shim, 0.003 (Green)	A/R				
29	074321-05	Shim, 0.002 (Red)	A/R				

* Specify 503936-02 for rubber drive wheel assembly or 503936-01 for poly drive wheel assembly.

** Used on trucks serial number 307942 and higher.

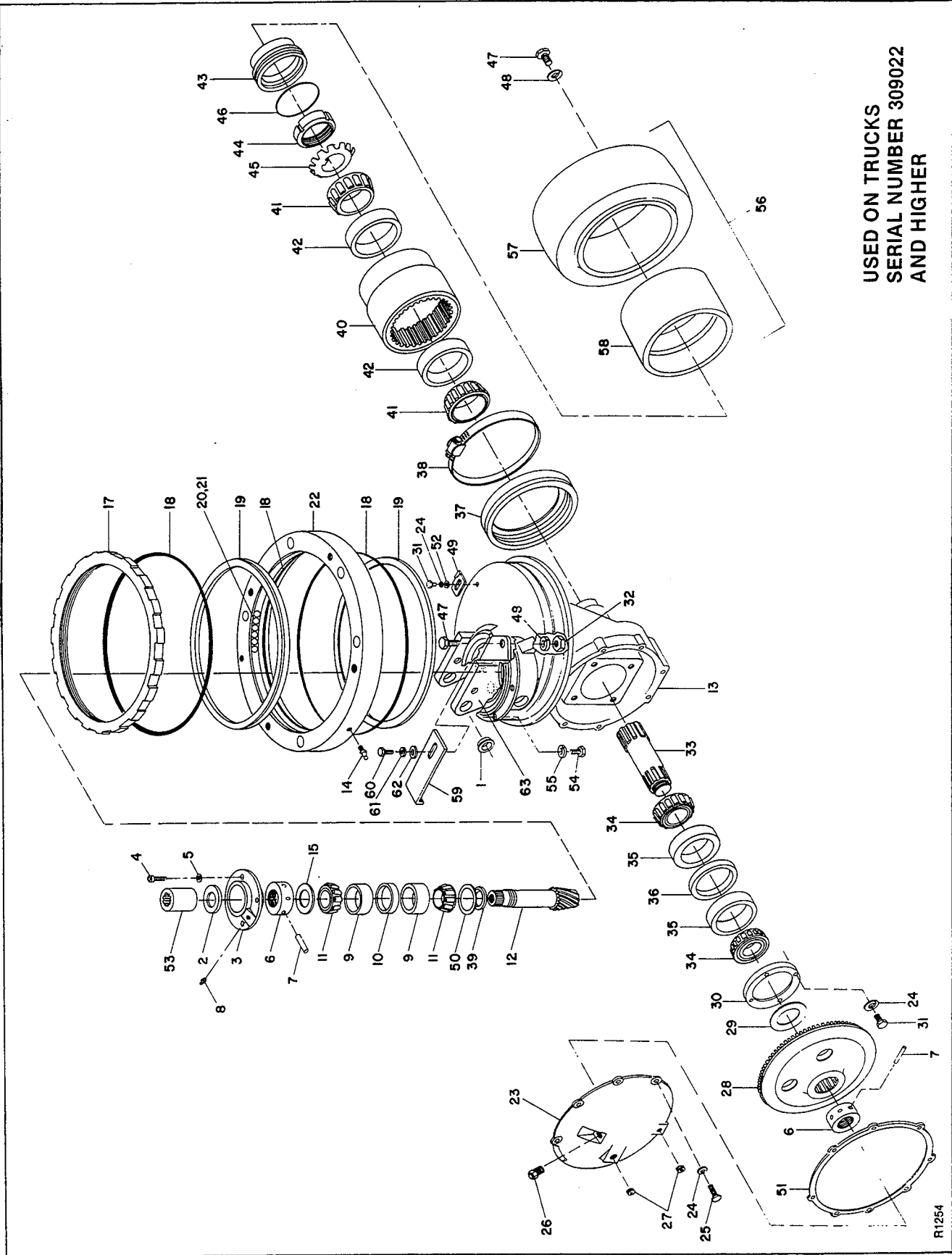

USED ON TRUCKS
SERIAL NUMBER 309022
AND HIGHER

Figure 3-7. Transmission and Drive Wheel (Sheet 2 of 2)

R1254

INDEX NO.	PART NO.	PART NAME	NO. REQD.	INDEX NO.	PART NO.	PART NAME	NO. REQD.
1	504021-01	Transmission Assembly	1	32	059437	Nut, Hex 1/2-13	3
2	053040-01	Flanged Bearing	2	33	057269	Spur, Pinion	1
3	043129	Oil Seal	1	34	051229	Cone, Bearing	2
4	800237	Bearing Cap	1	35	051228	Cup, Bearing	2
5	065555	Screw, Socket Hd., 5/16-18 UNC X 1	4	36	075080	Spacer, Bearing Cup	1
6	077117-01	Lock Washer, Hi-Collar, 5/16	4	37	073519	Seal, Special Transmission	1
7	059548	Locknut, Bearing	2	38	056134	Clamp, Adjustable	1
8	060977	Roll Pin, 3/16 X 1-3/4	2	39	075079	Spacer, Shield	1
9	025705	Grease Fitting	2	40	057270	Internal Spur Gear	1
10	051227	Cup, Bearing	1	41	051231	Cone, Bearing	2
11	075078	Spacer, Bearing Cup	2	42	051230	Cup, Bearing	2
12	051226	Cone, Bearing	1	43	800241	Bearing Retainer	1
13	057264	Pinion, Spiral Bevel	2	44	059682	Locknut, Bearing	1
14	800236	Main Housing, Transmission	1	45	077597	Lock Washer, Bearing	1
15	025704	Grease Fitting	1	46	042116	O-ring, 3.5 ID	1
16	077118	Washer, Flat 1-1/8	2	47	064711	Screw, Hex. Cap, 1/2-13 UNC X 1-3/4	8
17	800239	Not Used	1	48	077213	Lock Washer, 1/2 Split	8
18	057189	Bearing Retainer	1	49	401473	Retaining Clip	1
19	055183	Felt Strip	A/R	50	074324	Shim Pack	A/R
20	051232	Raceway, Bearing	1	51	057514	Gasket, Cover	1
21	051233	Ball, 7/16 Dia., Plain	43	52	077056	Spacer	1
22	051393	Ball, 27/64 Dia., Blk. Oxide	43	53	057268	Splined Coupling	1
23	401393	Outer Bearing Race	1	54	065480	Screw, Socket Hd. Cap, 1/4-20 UNC X 1	5
24	800238	Cover, Transmission	1	55	077117-02	Lockwasher, 1/4 Hi Collar	5
25	077211	Lock Washer, 3/8	13	56	503936*	Drive Wheel Assembly	1
26	064607	Screw, Hex., Cap, 3/8-16 UNC X 1-1/4	8	57	502281	Wheel, Rubber	1
27	076701	Breather	1	57	502280	Wheel, Poly	1
28	026310	Plug, Socket Hex., 3/8 NPT	2	58	800256	Hub	1
29	057266	Gear, Spiral Bevel	1	59	402068	Bracket	1
30	074321-01	Shim, 0.020 (Yellow)	A/R	60	063602	Bolt, Hex Hd., 3/8-16 x 58	1
31	074321-02	Shim, 0.010 (Brown)	A/R	61	077211	Lockwasher	1
32	074321-03	Shim, 0.004 (Tan)	A/R	62	077056	Spacer	1
33	074321-04	Shim, 0.003 (Green)	A/R	63	504419	Bracket	1
34	074321-05	Shim, 0.002 (Red)	A/R				
35	401392	Bearing Retainer	1				
36	064605	Screw, Hex. Cap, 3/8-16 UNC X 1	4				

*Specify 503936-02 for rubber drive wheel assembly or 503936-01 for poly drive wheel assembly.

1. Remove scerw (31), lock washer (24), flat washer (52) and retainer clip (49).

NOTE A few of the 1/2-13 hex head screws that hold the pivot bearing to the frame (33, figure 3-10) and associated lock washers (32) will have to be removed to provide spanner wrench clearance.

CAUTION Makeshift disassembly procedures may damage the transmission and make accurate preload adjustment impossible. Do not attempt to tighten or loosen the bearing retainers with such methods as hammering against the raised lugs. Use the official Big Joe spanner wrench, part number 900880.

2. Using the special spanner wrench, set the pivot bearing preload to 140 foot-pounds torque.
3. Place the retaining clip (49, figure 3-7) into the most convenient notch of the locknut (17) and secure with screw (31), lock washer (24), and flat washer (52).
4. Apply molybdenum disulfide grease with a low pressure grease gun to the two grease fittings (14) in the pivot bearing outer race (22).

e. Transmission Pivot Bearing Replacement.

NOTE A special spanner wrench for setting bearing preload may be obtained from Big Joe parts and service department. Wrench part number is 900880.

1. Remove steering arm (paragraph 3-10).
2. Remove electrical panel assembly and drive motor assembly (paragraph 3-12a, steps 1 through 12).
3. Block the drive wheel so that it cannot turn left or right.
4. Remove screw (31), lock washer (24), flat washer (52) and retaining clip (49).

NOTE Makeshift disassembly procedures may damage the transmission and make accurate preload adjustment impossible. Do not attempt to tighten or loosen the bearing retainer by such methods as hammering against the raised lugs. Use the official Big Joe spanner wrench, part number 900880.

CAUTION Ball bearings (20 and 21) may fall out of raceway (19) when bearing retainer (17) is removed. Take special care to catch ball bearings during disassembly.

5. Using the special spanner wrench, remove bearing retainer (17) and felt strips (18).
6. Remove bearing raceway (19) and ball bearings (20 and 21). Outer race (22) now may be removed.

7. Reassemble the pivot bearing in reverse order of disassembly with the following instructions.
- (a) When installing the steel ball bearings (20 and 21), they must be alternated by type, for example, one plain (20) followed by one black oxide (21) followed by one plain, etc.
 - (b) Prepack ball bearings with molybdenum disulfide grease and install with bearing raceway (19).
 - (c) Set pivot bearing preload to 140 foot/pounds torque as discussed in paragraph 3-12d. See table 3-5.

Table 3-5. Transmission Fasteners Torque Requirements

FASTENER	INDEX NO.	TORQUE
Hex Head Screw (Wheel)	47*	90 foot/pounds
Hex Head Screw (Bearing Retainer)	31	35 foot/pounds
Bearing Lockout (Gear)	6	12 inch/pounds
Hex Head Screw (Cover)	25	35 foot/pounds
Socket Head Cap Screws (Bearing Retainer)	4	30 foot/pounds
Bearing Retainer	17	140 foot/pounds
Socket Head Cap Screws (Motor)	54	16 foot/pounds
Bearing Locknut Spiral Bevel Pinion Assembly	6	7 inch/pounds

*Index numbers of figure 3-7.

f. Drive Wheel Replacement

1. Disconnect battery.
2. Securely block the load wheels to prevent the truck from moving.
3. Use a jack to raise the rear of the lift truck so that the drive wheel clears the ground.
4. Lower the truck on blocks, making certain the drive wheel is still clear of the ground.
5. Remove four screws (13, figure 3-10) and access cover (20).
6. Remove two flat head screws (25) and transmission stop (19).

CAUTION If a wheel puller is used, many have pointed center screws which may puncture the bearing retainer and cause oil leakage. Protect the bearing retainer by placing a piece of metal between the wheel puller center point and the bearing retainer.

8. Remove the eight hex head cap screws (47, figure 3-7) and lock washers (48) that secure the drive wheel to the internal spur gear (40) and then pull off the wheel.
9. Reverse the above procedure to install new drive wheel, making sure the hex head screws (47) are tightened to a torque setting of 90 foot/pounds.

3-13. Load Wheel and Bearing Replacement. (Figure 3-8)

1. Raise forks with hydraulic cylinder.
2. Disconnect battery.
3. Block the drive wheel to prevent the truck from moving.
4. Place a hydraulic jack under each fork at reinforced section behind the load wheel (6) and under the pull rod. Raise the forks until the load wheels clear the floor.
5. Remove locknut (13) securing load wheel to axle shaft.
6. Install new or repaired load wheel assembly.

NOTE Bearings and spacers are matched sets within the load wheel assembly and should not be mixed with other sets.

CAUTION Lubricate wheels when reassembling.

7. Reassemble by following steps 1 through 6 in reverse order. For wheel spindles with Zerk fittings lubricate with gun. For wheel spindles without Zerk fittings, repack bearing before installing.

NOTE Torque locknut (13) to 100 foot/pounds.

3-14. Load Wheel Housing Replacement. (Figure 3-8)

In order to perform the following procedure, the truck must be placed in a service position, either securely held off the floor, or carefully tipped on its side. If proper hoists or jacks are available, lower the forks as far as they will go, raise the truck off the floor and proceed with the service.

1. Place truck in service position. If tipping the truck is necessary, perform the following:
 - (a) Lower the forks all the way, and then disconnect and remove the battery.
 - (b) Plug the hydraulic reservoir breather vent with 3/8 NPT pipe plug.
 - (c) Disconnect the high-pressure hydraulic hose at the pump and place the free end of hose in a clean container to catch the oil that may drain from lift cylinders.
 - (d) Carefully tip truck onto its side.
2. Loosen nuts (22) away from spring plate (23) to release spring tension from pull rod assembly.
3. Disconnect the extension spring (21).
4. Remove roll pin (18) securing wheel housing pivot shaft (36) and pull shaft out of fork.
5. Remove snap ring (16) and exit roller (15) thrust washer (3) from shaft (14).
6. Remove roll pin (18) securing shaft (14) to wheel housing and pull shaft out of housing.
7. Disassemble load wheel housing assembly (6) as shown in figure 3-8.
8. Install new or repaired load wheel housing assembly by following steps 1 through 7 in reverse sequence.
9. Adjust pull rod length as described in paragraph 3-15a if necessary.

NOTE If load wheel is disassembled from housing (7), reassemble using torque setting of 100 foot-pounds on locknut (13).

3-15. Lift Linkage Repair.

In order to perform the following procedures, the truck must be placed in a service position, either securely held off the floor, or carefully tipped on its side. If proper hoists or jacks are available, lower the forks as far as they will go, raise the truck off the floor and proceed with the service. If you must tip the truck, perform the following steps.

1. Lower the forks all the way, and then disconnect and remove the battery.
2. Plug the hydraulic reservoir breather vent with 3/8 NPT pipe plug.
3. Disconnect the high-pressure hydraulic hose at the pump and place the free end of hose in a clean container to catch the oil that may drain from lift cylinder.
4. Carefully tip truck onto its side.

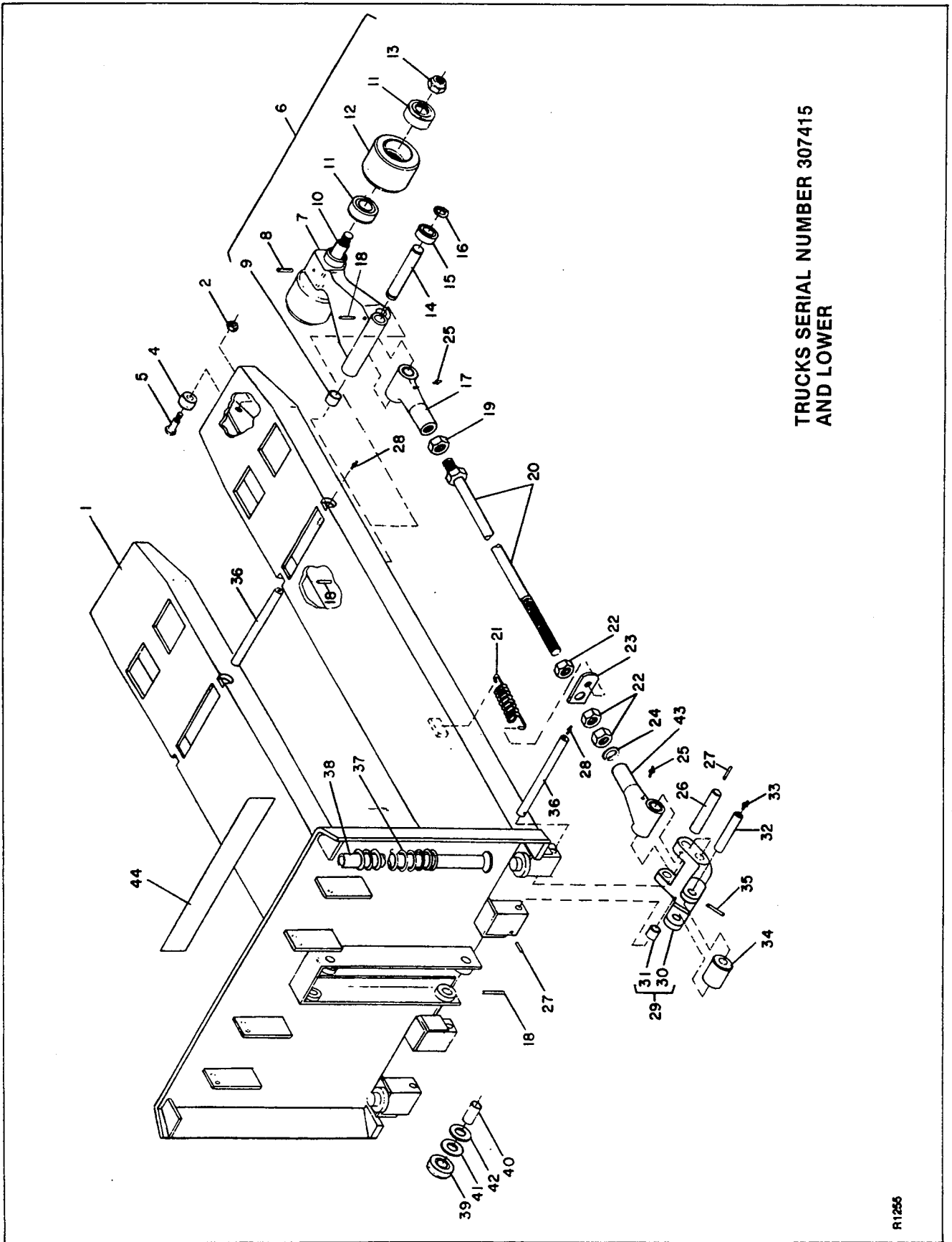
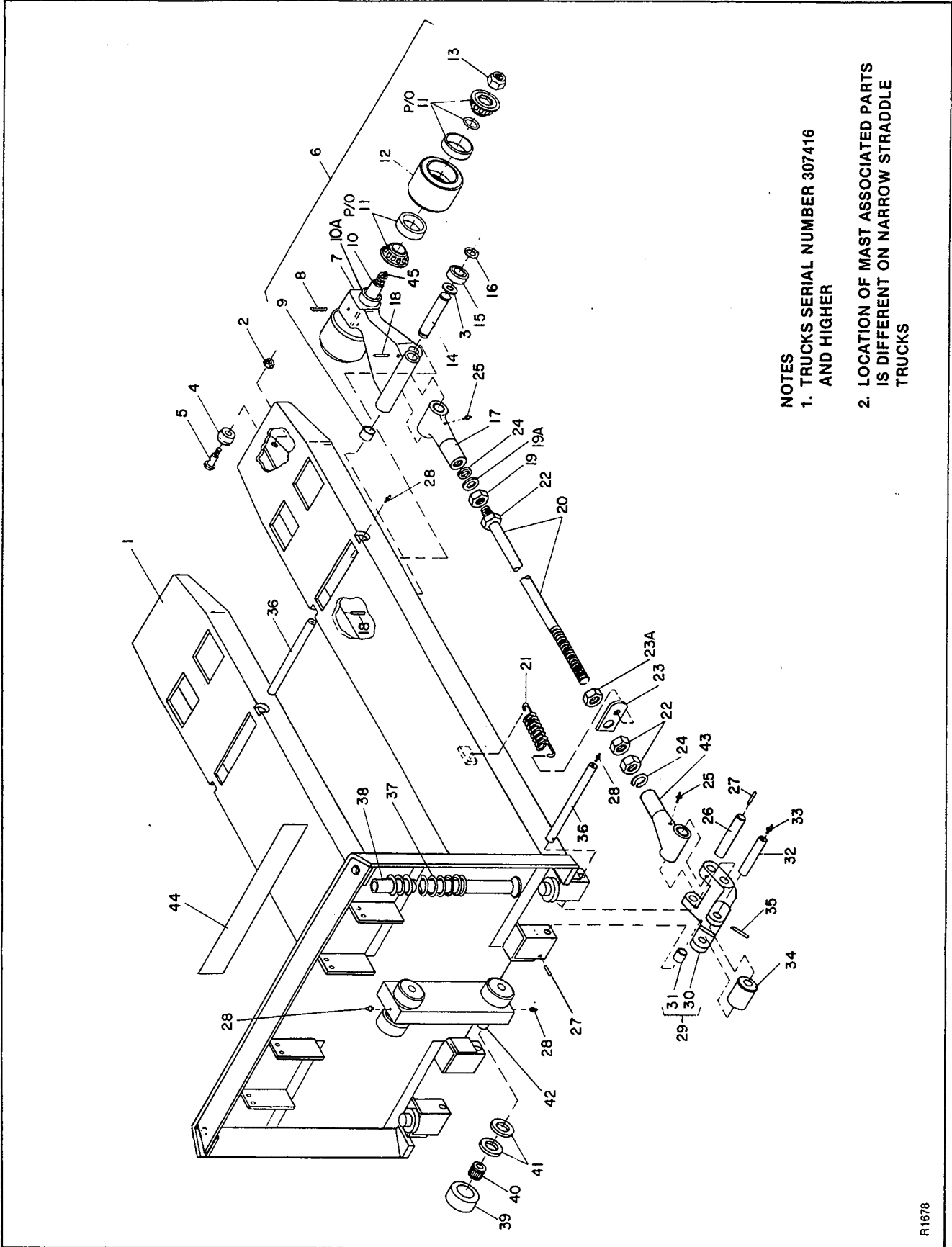

Figure 3-8. Backrest/Fork Assembly (Sheet 1 of 2)

INDEX NO.	PART NO.	PART NAME	NO. REQD.	INDEX NO.	PART NO.	PART NAME	NO. REQD.
1	504010*	Backrest/Fork Assembly	1	26	401504	Shaft	2
2	503960*	Fork and Backrest Weldment	1	27	061006	Roll Pin, 1/4 X 1-1/4	4
3	059645	Nut, Lock 5/8-18 UNF	6	28	025704	Grease Fitting	4
4	503955-01	Not Used	6	29	503958	Pull Link Assembly	2
5	401503	Roller Assembly	6	30	800232	Pull Link	1
6	503963	Shoulder Bolt	6	31	052941-01	Bearing, Sleeve	2
7	800229	Load Wheel and Housing Assembly	2	32	401505	Pin, Roller, 0.625 OD X 3-3/8	2
8	061010	Load Wheel Housing	1	33	025701	Grease Fitting, 90°	2
9	052941-01	Roll Pin, 1/4 X 1-3/4	1	34	503962	Roller Assembly	2
10	401506	Bearing	2	35	060974	Roll Pin, 3/16 X 1-1/4	2
11	051225**	Shaft, Load Wheel	1	36	401497	Shaft, Pivot	4
12	078264**	Bearing Set	2	37	075077	Spring, Compression	2
13	059130	Load Wheel	2	38	057614	Spring Guide, Tube	2
14	401496	Locknut, Hex., Thin 7/8-14 UNF-3B	2	39	503956	Roller Assembly, Mast	4
15	503955-02	Shaft	2	40	401498	Shaft, Mast Roller	4
16	061719	Roller Assembly	4	41	077116	Thrust Washer, 0.8905 ID X 1/6 Thk	4
17	503957-02	Snap Ring, Ext. 3/4	4	42	074312-01	Shim, 0.010	A/R
18	061008	Clevis Assembly	2	42	074312-02	Shim, 0.020	A/R
19	059452	Roll Pin, 1/4 X 1-1/2	8	42	074312-03	Shim, 0.030	A/R
20	503952*	Nut, 7/8-14 UNF, Left Hand Thread	2	43	503957-01	Clevis Assembly	2
21	075084	Pull Rod	2	44	056499	Decal, NO RIDING	1
22	059451	Spring, Extension	2				
23	401399	Nut, 7/8-14 UNF, Right Hand Thread	6				
24	077221	Plate, Spring	2				
25	025702	Lock Washer, 7/8 Split Grease Fitting	2				

* Add "-06" to part number for 60-inch backrest/fork, add "-05" to part number for 54-inch backrest/fork, add "-03" to part number for 48-inch backrest/fork, add "-02" to part number for 42-inch backrest/fork and "-01" to part number for 36-inch backrest/fork.

** Order load wheel and bearing together as a matched set using part number 504146.



- NOTES**
1. TRUCKS SERIAL NUMBER 307416 AND HIGHER
 2. LOCATION OF MAST ASSOCIATED PARTS IS DIFFERENT ON NARROW STRADDLE TRUCKS

Figure 3-8. Backrest/Fork Assembly (Sheet 2 of 2)

R1678

INDEX NO.	PART NO.	PART NAME	PART NO.	PART NAME	NO. REQD.
31	052941-01	Bearing, Sleeve			2
32	401505	Pin, Roller, 0.625 OD X 3-3/8			2
33	025701††	Grease Fitting, 90°			2
33	025704††	Grease Fitting			2
34	503962††	Roller Assembly			2
34	504356†	Roller Assembly			2
35	060974	Roll Pin, 3/16 X 1-1/4			2
36	401497††	Shaft, Pivot			4
36	401710†	Shaft			4
37	075077	Spring, Compression			2
38	057614	Spring Guide, Tube			2
—	500166	Roller Bearing Assy			4
39	243401	Roller			4
40	051145	Bearing			4
41	053012	Roller Spacer, 3/16 in. thick			A/R
41	053013	Roller Spacer, 3/32 in. thick			A/R
42	236001	Spindle, 1-1/4 in. dia.			4
43	503957-01	Clevis Assembly			2
44	056499	Decal, NO RIDING			1
45	025713	Grease Fitting			4

* USE APPROPRIATE PART.

CHART 1

FORK END ASSEMBLY NO.	DASH NO.	BACKREST WLDMNT NO.	FORK AND BACKREST DASH NO.	PULL ROD ASSEMBLY NO.	DASH NO.	LENGTH
504372	-01	504370	-01	504376	-01	36
504372	-02	504370	-02	504376	-02	42
504372	-03	504370	-03	504376	-03	48
504372	-04	504370	-04	504376	-04	50,56
504372	-05	504370	-05	504376	-05	54
504372	-06	504370	-06	504376	-06	60
504375	-01	504370	-07	504376	-05	64
504375	-02	504370	-08	504376	-06	76
504375	-03	504370	-09	504376	-07	84

CHART 2

FORK END ASSEMBLY NO.	DASH NO.	BACKREST WLDMNT NO.	FORK AND BACKREST DASH NO.	PULL ROD ASSEMBLY NO.	DASH NO.	LENGTH
504379	-01	504352	-01	504376	-01	36
504379	-02	504352	-02	504376	-02	42
504379	-03	504352	-03	504376	-03	48
504379	-04	504352	-04	504376	-05	54
504379	-05	504352	-05	504376	-06	60

† Parts for narrow straddle assy only.
 †† Parts for standard straddle assy only.

INDEX NO.	PART NO.	PART NAME	NO. REQD.
	504372*	Backrest/Fork Assembly (See Chart 1)	1
	504379†	Backrest/Fork Assembly (See Chart 2)	2
1	504370*	Fork and Backrest Weldment (See Chart 1)	1
	504352*	Fork and Backrest Weldment (See Chart 2)	2
2	059645	Nut, Lock 5/8-18 UNF	6
3	077115	Thrust Washer	10
4	503955-01	Roller Assembly	6
5	401503	Shoulder Bolt	6
6	503963††	Load Wheel and Housing Assembly	2
6	504105†	Load Wheel and Housing Assembly	2
7	800229††	Load Wheel Housing	1
7	800249†	Load Wheel Housing	1
8	061010	Roll Pin, 1/4 X 1-3/4	1
9	052941-01	Bearing	2
10	401506††	Shaft, Load Wheel	1
10	401714†	Shaft, Load Wheel	1
10A	401713†	Spacer	1
11	051225	Bearing Set	2
12	078264††	Load Wheel	2
12	078267†	Load Wheel	2
13	059130	Locknut, Hex., Thin 7/8-14 UNF-3B	2
14	401496	Shaft	2
15	503955-02	Roller Assembly	2
16	061719	Snap Ring, Ext. 3/4	4
17	503957-02	Clevis Assembly	4
18	061008††	Roll Pin, 1/4 X 1-1/2	2
18	061006†	Roll Pin, 1/4 X 1-1/4	4
19	059452	Nut, 7/8-14 UNF, Left Hand Thread	1
20	504376*††	Pull Rod (See Chart 1)	2
	504376†	Pull Rod (See Chart 2)	2
21	075084††	Spring, Extension	2
21	075085†	Spring, Extension	2
22	059451	Nut, 7/8-14 UNF, Right Hand Thread	2
23	401399	Plate, Spring	6
23	401707†	Bracket	2
23a	401708	Nut, Spring Retainer	2
24	077221	Lock Washer, 7/8 Split	4
25	025702	Grease Fitting	4
26	401504	Shaft	4
27	061006	Roll Pin, 1/4 X 1-1/4	2
28	025704	Grease Fitting	4
29	503958	Pull Link Assembly	6
30	800232	Pull Link	2

a. Adjustment of Pull Rod. (Figure 3-8)

NOTE There can be no upward forces on the backrest/fork when making pull rod adjustments. The backrest/fork must be freely suspended from the frame for the correct adjustment to be made.

To insure even raising and lowering of forks and correct lowered height of forks, the pull rods must be properly adjusted. Follow this procedure to adjust the pull rods.

1. Place the truck in a service position.
2. Loosen nuts (22) away from spring plate (23) to release spring tension on the pull rod assembly.
3. Disconnect the extension spring (21).
4. Loosen jam nuts (22 and 19) from against the clevises (17 and 43).
5. Turn the pull rod (20) so that wheel housing assembly (6) backs up against the underside of the fork.

NOTE A large C-clamp may be used to hold the wheel housing assembly against the underside of the fork.

6. Lock the wheel housing assembly against the underside of the fork.
7. Turn pull rod in the opposite direction until roller (34) rests snugly against the roller pad portion of the frame (under the battery compartment). Do not overtighten.
8. Replace tension spring and spring plate, and tighten jam nuts (22 and 19) against clevises (17 and 43).
9. Repeat the procedure for the other pull rod.
10. Return truck to normal operating position and restore it to operating condition. Add hydraulic oil if necessary.
11. Select a relatively smooth, flat area free of debris to test the adjustment.
12. Without a load, raise and lower forks several times and watch for rocking or tilting of truck or uneven lifting of forks.
13. Correct lowered height of truck should be approximately 3-1/8 inches. If lowered height exceeds 3-3/8 inches, adjust pull rods following instructions for adjustment of pull rod given in steps 1 through 11.

b. Removal of Pull Rod. (Figure 3-8)

1. Place truck in a service position.
2. Loosen nuts (22) beside spring plate (23) to release spring tension.
3. Disconnect the spring (21).

NOTE Pull rod (20) has a right-hand thread on one end and a left-hand on the other end.

4. Loosen nut (22) and left-hand nut (19) from against clevises (17 and 43).
5. Unscrew pull rod from the front clevis by turning clockwise.
6. Unscrew pull rod from the rear clevis by turning counterclockwise.

c. Installation of Replacement Pull Rod Assembly.

Before a new pull rod is installed, inspect old wheel housing shafts (36, figure 3-8) for wear, and replace if necessary. New roll pins should be used to insure snug fit.

To install pull rod assembly refer to figure 3-8, and follow this procedure.

NOTE Pull rod (20) has a right-hand thread on one end and a left-hand thread on the other end.

1. Place the truck in a service position.
2. Install jam nut (19) on the front (left-hand thread) end of the pull rod.
3. Screw to front end of the pull rod into the front clevis (17).
4. Install the following on the pull rod rear end, one nut (22), spring plate (23), two more nuts (22) and lock washer (24).
5. Install pull rod rear end into rear clevis (43)
6. Connect the spring plate to the boss welded to the underside of the fork with the extension spring (21).
7. Adjust pull rod length as described in paragraph 3-15a.

3-16 Roller Removal

1. Raise the forks.
2. Block the drive wheel to prevent the truck from moving.
3. Provide adequate support for the forks.
4. Disconnect the battery.
5. To remove an entry roller, remove the associated shoulder bolt (5, figure 3-8), roller (4), and nut (2).
6. To remove and exit roller, follow instructions for load wheel housing replacement, paragraph 3-14, steps 1 through 5.

3-17. Caster Bearing Replacement. (Figures 3-9 and 3-10)

1. Block the load wheel to prevent truck from moving.
2. Disconnect the battery.
3. Raise the rear of the truck with a jack or a second lift truck and place supports under the frame approximately six inches in front of the caster assemblies.
4. Lower the truck onto the supports.

5. Remove the platforms (44, figure 3-10) by removing screws (42) and washers (32 and 43).
6. Remove the four screws (13) and remove the caster assembly (14) and bearing housing (15).
7. Remove snap ring (1, figure 3-9) and spacer (2) and pull bearing housing off caster assembly.
8. Press out and discard damaged bearing (3) after removing retainer ring (14).
9. Reassemble and reinstall caster assembly with new bearing in place by performing steps 1 through 8 in reverse sequence.

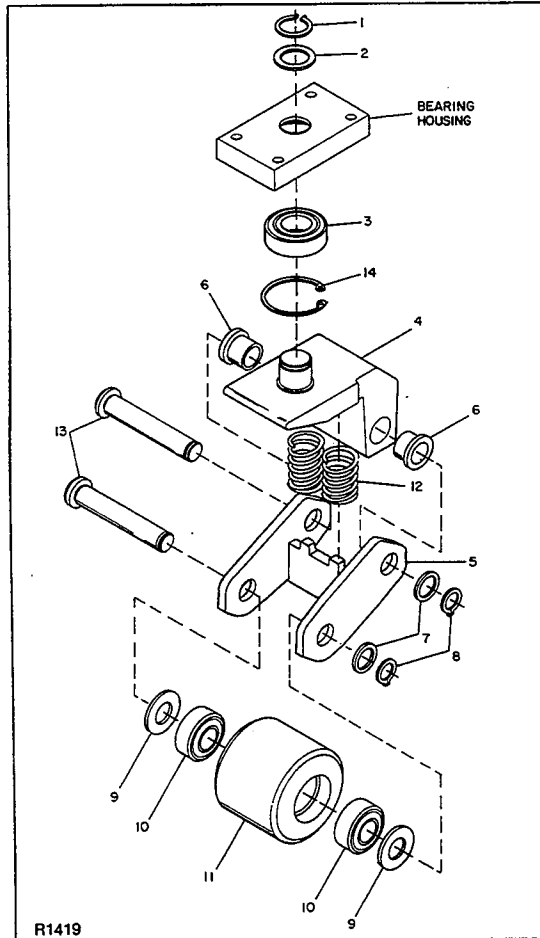

Figure 3-9. Caster Assembly

INDEX NO.	PART NO.	PART NAME	NO. REQD.
	503891-01†	Caster Assembly (14, Figure 3-10)	REF
	503841-04††	Caster Assembly	
1	061725	Snap Ring, Ext. 1"	1
2	401318	Spacer	1
3	051153	Bearing	1
4	800227	Base	1
5	800226	Arm	1
6	052940	Bushing	2
7	401323	Spacer	2

INDEX NO.	PART NO.	PART NAME	NO. REQD.
8	061719	Snap Ring, Ext. 3/4"	2
9	051154	Thrust Bearing	2
10	051152	Bearing	2
11	078263	Wheel	1
12	075075†	Spring	2
	075086††	Spring	2
13	401319	Axle	2
14	061745	Snap Ring	1

†For battery weight under 800 lbs.

††For battery weight over 800 lbs.

3-18. Caster Wheel Bearing Replacement. (Figure 3-9)

1. Block load wheels to prevent the truck from moving.
2. Disconnect the battery.
3. Raise the rear of the truck with jack or a second lift truck and place supports under the frame approximately six inches in front of the caster assemblies.
4. Lower the lift truck onto the supports.
5. Remove snap ring (8) from wheel axle (13). Remove spacer (7) and slide out axle so wheel (11) can be removed.
6. Remove wheel, retaining thrust bearing (9) for inspection and possible reuse.
7. Press out damaged bearing(s) (10) and install new bearing(s).
8. Reassemble and reinstall the caster assembly by performing steps 1 through 7 in reverse sequence.

3-19. Base and Frame. (Figure 3-10)

Figure 3-10 identifies and locates parts associated with the base and frame. No special procedures are required, except the following, which explains removal of the backrest/fork assembly.

In order to perform the following procedures, the truck must be placed in a service position, either securely held off the floor, or carefully tipped on its side. If proper hoists or jacks are available, lower the forks as far as they will go, raise the truck off the floor and proceed with the service.

WARNING Before disconnecting any hydraulic lines, make sure the hydraulic system is not under pressure.

1. Place truck in service position. If the truck must be tipped, perform the following:
 - (a) Lower the forks all the way, and then disconnect and remove the battery.
 - (b) Plug the hydraulic reservoir breather vent with 3/8 NPT pipe plug.
 - (c) Disconnect the high-pressure hydraulic hose at the pump and place the free end of hose in a clean container to catch the oil that may drain from lift cylinders.
 - (d) Carefully tip truck onto its side.
2. Disconnect the hydraulic hose (9, figure 3-25) where it joins swivel connector (12) under the battery compartment.
3. Remove truck from service position and set on floor.
4. Slightly raise the backrest/fork.
5. Install jacks or other adequate supports beneath each fork.
6. Remove the two screws (4, figure 3-10) that fasten the hydraulic compartment cover (5) to the truck and remove the hydraulic compartment cover.
7. Remove the eight screws (3, figure 3-25) and lock washers (4) from the backrest/fork brackets above the lift cylinders, and remove the mounting bar (5).

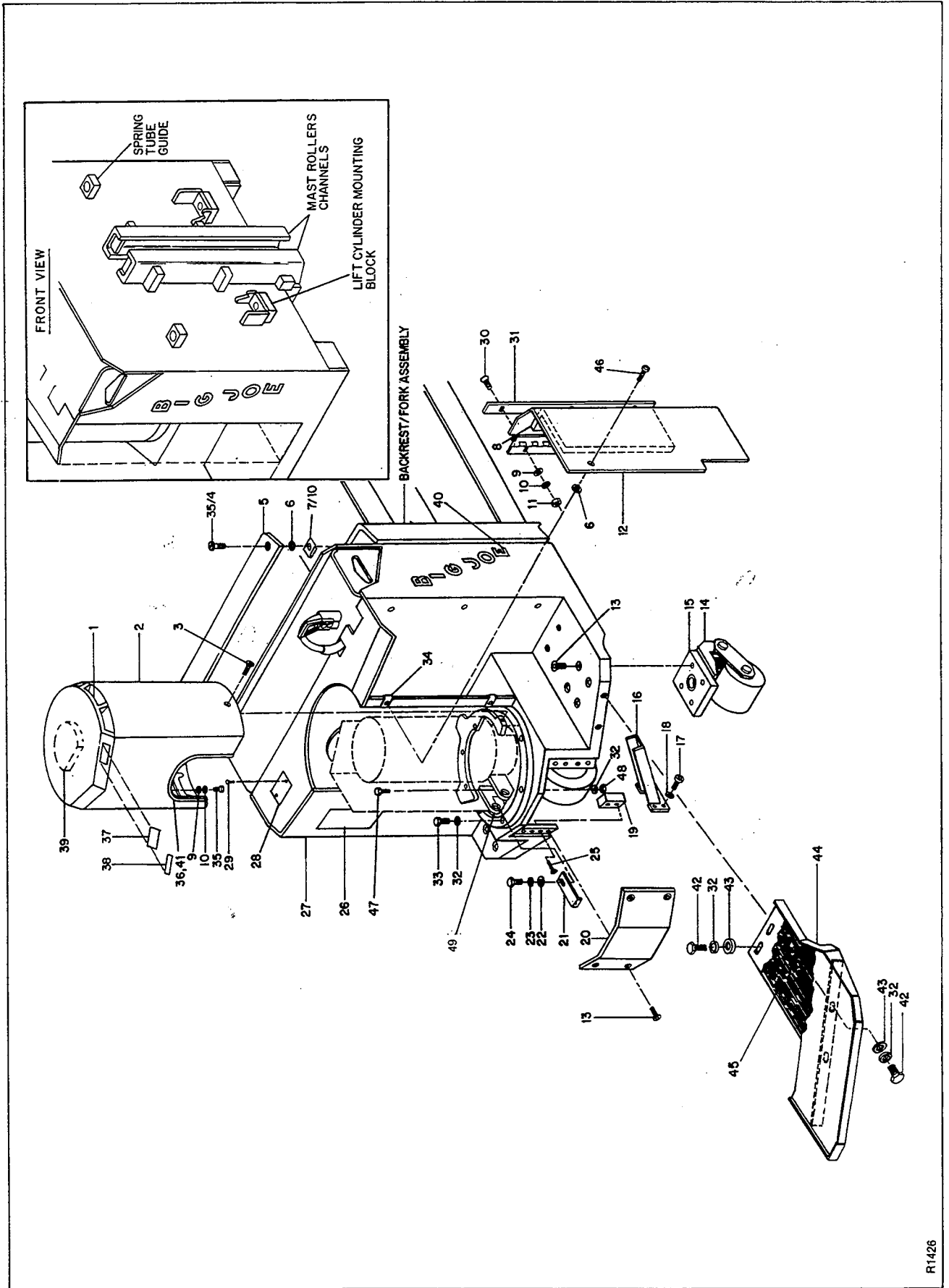

Figure 3-10. Base and Frame

INDEX NO.	PART NO.	PART NAME	NO. REQD.
1	800235	Cover	1
2	503917	Motor Cover Weldment	1
3	069715	Screw, Flat Ph Hd., 1/4-20 UNC X 3/4 w/nylok	3
4	067403 Δ Δ	Screw, Fastener #12	2
5	402014	Cover, Hydraulic Compartment	1
6	402030 Δ	Cover, Hydraulic Compartment	1
7	067404	Retainer, Screw	4
8	067406 Δ Δ	Clip, U-type	2
9	060105	Soundproofing Pad	2
10	077031	Washer, Flat 1/4	11
11	077209	Lockwasher, 1/4 Split	11
12	059421	Nut, Hex., 1/4-20 UNC	6
13	503972	Door Weldment, Right Side	1
14	069706	Screw, Hex. Socket Flat Hd., Selflock 1/2-13 UNC X 1	12
15	503891-01††	Caster Assembly (See Figure 3-9)	1
16	503891-04††	Caster Assembly (See Figure 3-9)	2
17	401481	Bearing Housing	2
18	503951	Cable Guard Weldment	1
19	065451	Screw, Socket Hd., 10-32 UNF X 3/8 Lg.	4
20	077208	Lockwasher, No. 10	4
21	401600	Transmission Stop	1
22	401441	Access Door	1
23	401468 Δ Δ	Stop, Adjustable	1
24	402068**	Bracket	1
25	402071 Δ Δ	Spacer	1
26	077056**	Washer	1
27	077211	Lockwasher, 3/8	1
28	063602**	Bolt, Hex. Hd, 3/8-16 X 5/8	1
29	069712	Screw, Socket Flat Hd., Selflock 3/8-16 UNC X 3/4	2
30	056601	Decal, Operating Instructions	1
31	503971	Door Weldment, Left Side	1
32	061300	Name Plate	1

†For battery weight under 800 lbs.

††For battery weight over 800 lbs.

**For trucks, serial no. 309022 and higher

Δ For narrow configuration

Δ Δ Used on trucks serial number 309021 and lower

INDEX NO.	PART NO.	PART NAME	NO. REQD.
29	066050	Drive Screw, 3/32 X 1/4 Lg.	2
30	069483	Screw, Flat Ph. Hd., 1/4-20 UNC X 1-1/2	6
31	401482	Hinge Spacer	2
32	077213	Lockwasher, 1/2 Split	17
33	063715	Screw, Hex. Hd., 1/2-13 X 2-1/4	6
34	067405	Clip, U-type	4
35	063478	Screw, Hex. Cap, 1/4-20 X 3/4	7
36	052896	Rubber Guard	A/R
37	056595	Decor Logo	1
38	056596-03	Decal, Model Number Insert WRT-40	1
39	060104	Decal, Model Number Insert WRT-60	1
40	056516	Soundproofing Pad	1
41	— —	Decal	2
42	063705	Adhesive for part 36	REF
43	077104	Screw, Hex. Hd. 1/2-13 X 1 Washer, Flat	8
44	504001	Platform, Weldment RH	1
45	504000	Platform, Weldment LH	1
46	318508	Mat, Floor RH	1
47	318509	Mat, Floor LH	1
48	067402	Screw, Fastener	4
49	064711**	Screw, Hex Hd 1/2-13 x 1-3/4 lg	3
50	059437**	Nut, Hex 1/2-13	3
51	504419**	Bracket Assembly	1

8. Remove the lift cylinders (6) and hose assemblies from the lift cylinder mounting blocks which are welded to the frame.

WARNING The lift truck frame weighs in excess of 700 pounds without the battery. Make sure the hoist or jacks chosen to lift it clear are of sufficient capacity to provide an adequate margin of safety.

9. Lift the base and frame clear of the backrest/fork and set aside.

CAUTION When reassembling, make sure that the lift cylinders fit into the lift cylinder mounting blocks, that the mast roller assemblies (39, figure 3-8) fit inside the mast roller channels, and that the spring tubes (37) slide into the spring tube guides (38).

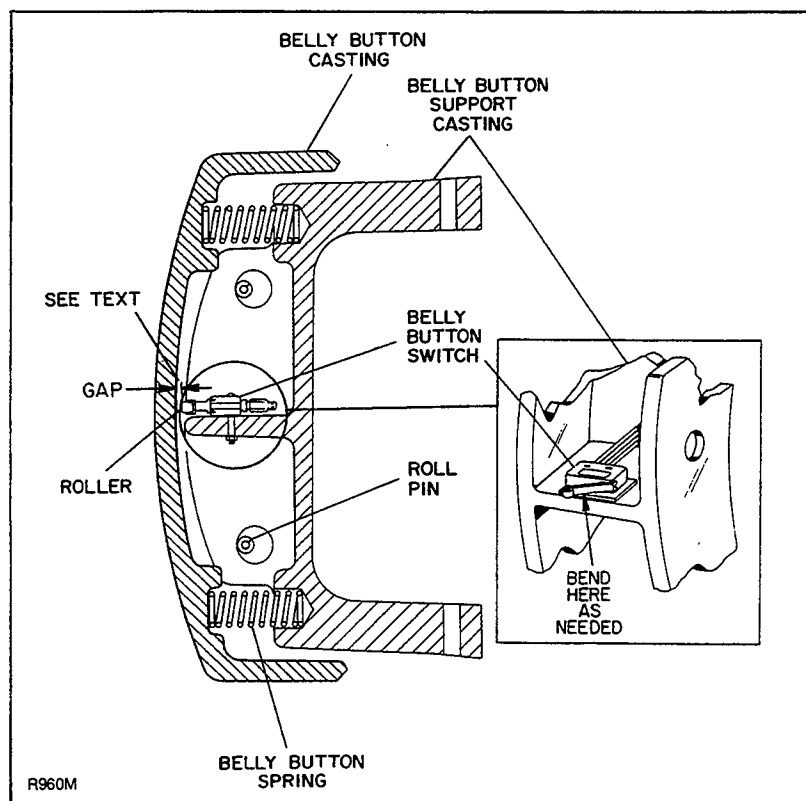

Figure 3-11. Belly-Button Safety Switch

3-20. Belly-Button Switch Adjustment. (Figures 3-11 and 3-12)

Adjust the actuator gap of the belly-button safety switch according to the following procedure:

1. Disconnect the battery.

NOTE While removing the belly-button casting, two springs (needed for reassembly) will fall free.

2. Being careful to catch and retain the springs (42, figure 3-12) that will fall from the belly-button support casting (47) as the belly-button casting is removed, drive out the roll pins (40) that secure the belly-button casting.

NOTE Be sure to drive roll pins (40) out the side of the belly-button casting as shown in figure 3-12; the holes are larger on that side of the belly-button casting.

CAUTION Too small a gap between belly-button switch actuator roller and the belly-button casting may cause the belly-button switch to be actuated constantly.

3. Bend actuator lever of belly-button switch to adjust gap between roller and belly-button casting as required (see figure 3-11).
4. Reinstall belly-button casting, making certain all parts are back in place.
5. Check operation of the belly-button switch by pressing the belly-button casting while listening for the "click" that indicates that the switch has actuated.

NOTE The click should be heard when the belly-button casting has moved about 50 per cent of its normal travel distance. If the click is heard at the beginning of travel, the switch may actuate at inappropriate times. If the click is heard near the end of travel, it could be unreliable and may not switch in some instances.

6. Repeat steps 2 through 5 until pressing the belly-button casting actuates the switch properly.
7. Reconnect the battery.

WARNING Testing of belly-button switch should be limited to areas clear of obstacles against which an operator could be pinned.

3-21. Control Head Lubrication and Switch Replacement. (Figure 3-12)

a. Control Head Lubrication

The parts requiring lubrication are the return spring, Figure 3-12) (Inset A) and the switch cam, (Inset B). Lubricate whenever, spring, cam or PC board is replaced.

CAUTION Use grease sparingly. Grease only surfaces specified, using a moly grease (MoS).

1. Coat the return spring, (Inset A) on all contact surfaces as shown. Separate the coils slightly to assure grease penetration.
2. Lightly coat the switch cam, (Inset B) only on the surfaces where contact with switch rollers occurs. Wipe off any excess grease.

CAUTION Do not allow any grease to drop on the printed circuit board or into switches.

b. Switch Replacement

1. Disconnect the battery.

NOTE Access to belly-button switch is provided by removal of belly-button casting, access to lift, lower, brake and horn switches is provided by removal of right and left side switch boxes.

2. Remove belly-button casting (41) by performing steps 1 and 2 in paragraph 3-20 if necessary to gain access to defective belly-button switch.

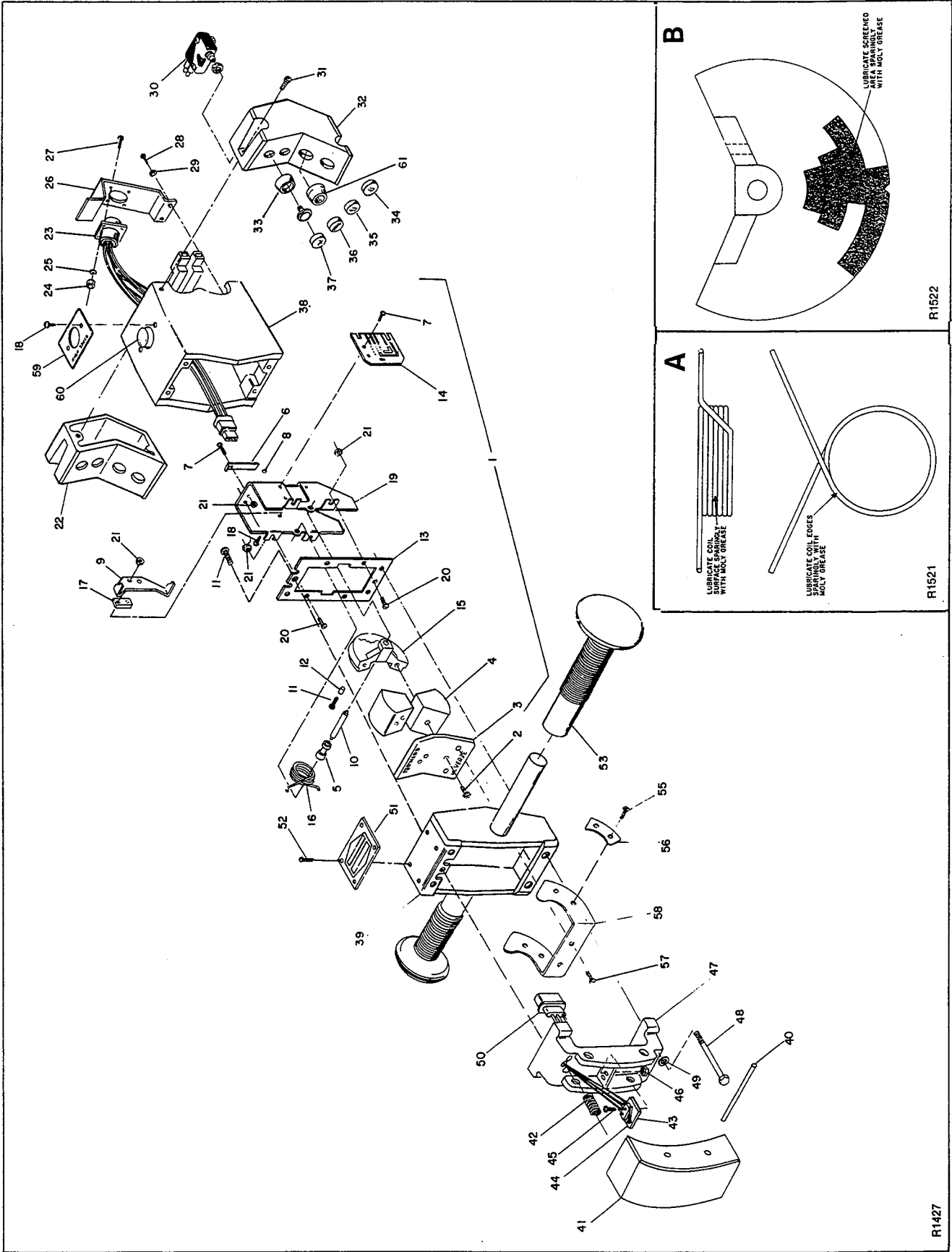

R1522

R1521

R1427

Figure 3-12. Control Head Assembly

INDEX NO.	PART NO.	PART NAME	NO. REQD.
1	504041	Control Head Assembly, 12V	1
2	504078	Control Head Assembly, 24V	1
3	072413	Speed Control Switch	3
4	800245	Screw, Flat Hd. Thread Cutting 5-40 UNC X 1/2	1
5	055516	Switch Cover	2
6	074708	Spacer	1
7	075074	Ball Retainer	1
8	067412	Screw, Pan Head 5-40 UNC X 1/4	4
9	053367	Ball Bearing, 3/16 Dia.	1
10	052813	Spring Retainer	1
11	074710	Pivot Shaft	1
12	072415	Screw, Pan Head, 4-40 UNC X 5/8	4
13	074711	Spacer	2
14	052818	Switch Plate	1
15	018203	PC Board and Switch Assembly	1
16	055517	Switch Cam	1
17	075073	Return Spring	1
18	052819	Spacer, Spring Retainer	1
19	067413	Screw, Pan Head 5-40 UNC X 1/2	4
20	052812	Switch Enclosure, Speed Control Switch	1
21	069461	Screw, Flat Head 5-40 UNC X 1/2	4
22	059632	Nut, Hex., With NYLOC Insert 5-40 UNC	7
23	800209	Switch Box, Left Side	1
24	023091	Speed Control Harness	1
25	059410	Nut, Hex. 5-40	4
26	077203	Washer, Lock No. 5, Split	4
27	052820	Connector Mounting Plate	1
28	068177	Screw, Mach. Rnd. Hd., 5-40 UNC X 3/8	4
29	067414	Screw, Pan Head 10-24 UNC X 3/8	4
	077207	Washer, Lock No. 10 Split	4
30	023086	Switch, Pushbutton	8
31	065454	Screw, Socket Head Cap 10-24 UNC X 5/8	4
32	800210	Switch Box, Right Side	1
33	023087	Bezel, Switch	8
34	056582	Pushbutton, Lower	2
35	056581	Pushbutton, Raise	2
36	056584	Pushbutton, BRAKE	2
37	056583	Pushbutton, Horn	2
38	052895	Plunger, Switch (used with pushbuttons)	8
39	800211	Handle	1
40	503912	Handle Bracket	1
41	061018	Pin, Roll 1/4-3-1/2 Lg.	2
42	800215	Belly-Button Casting	1
43	075510	Spring	2
44	018202	Insulator	1
45	503795	Belly-Button Switch and Harness	1
46	070486	Screw, Rnd. Hd. 2-56 UNC X 1	2
47	059633	Nut, Hex. With Nyloc Insert 2-56	2
48	800216	Belly-Button Support Casting	1
49	063491	Screw, Hex. Cap, 1/4-20 UNC X 3-1/2	4
50	077209	Washer, Lock 1/4 Split	4
51	005647	Connector	1
52	056594	Decal, FORWARD REVERSE	1
53	066051	Screw, Drive Rnd. Hd., 3/16 Lg.	4
54	057502	Handle Grip, Rubber	2
55	077054	Spacer, Nylon	2
56	068340	Screw, But. Hd. 8-32 X 5/16	4
57	055636	Grip-Lever, Control RH	1
58	055637	Grip-Lever, Control LH	1
59	068338	Screw, Fl. Hd. 8-32 X 1/4	2
60	401580	Lever Control, Side	1
61	056602	Decal, High Speed Switch (24V)	1
	023106	Switch, High Speed (24V)	1
	077054	Spacer, Nylon (Spacer Under Bezel on Brake Only)	2

3. Remove socket head screws (2, figure 3-3) to detach control head and gain access to speed control harness (23, figure 3-12).
4. Disconnect and remove connector mounting plate (26) and speed control harness.
5. Disconnect pushbutton switch (30), and remove switch box (22 and/or 32).

NOTE PC board and switch assembly (14) on the speed control switch (1) are actuated by switch cam (15) in the sequence indicated in figure 3-13, Switch Cam.

6. Check that the speed control switch is actuated properly by the switch cam as shown in figure 3-13 (area F1 actuates first speed forward and so forth). At this time, check that the high speed pushbutton switch on the control head of 24 volt electrical systems works properly.
7. Replace the speed control switch (1, figure 3-12), belly-button switch (44), horn switch (30), dynamic brake switch (30) or high speed switch (60) as required.

NOTE If the belly-button switch is replaced, adjust it in accordance with paragraph 3-20 before using truck.

8. After replacing defective switch(es), reinstall switch box and/or belly-button casting, as required, making certain that all parts are put back in place.
9. Reconnect electrical connectors and connect battery.

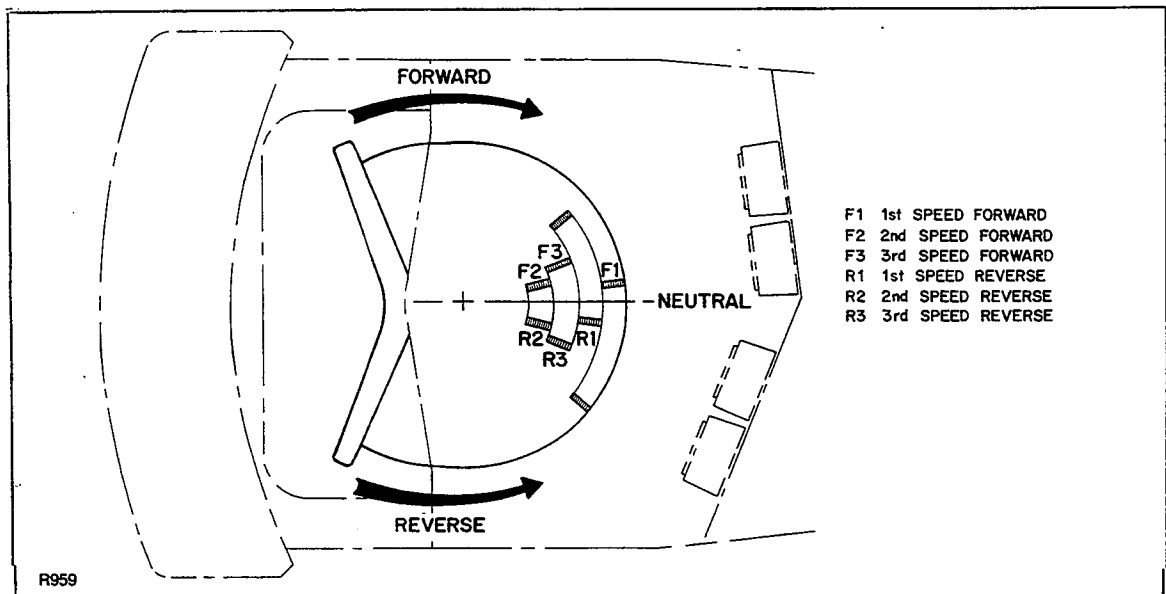

Figure 3-13. Switch Cam

3-22. Electrical Shaft Cable Replacement. (Figure 3-14)

1. Disconnect battery.
2. Remove 4 screws that fasten control head to steering arm.
3. Disconnect the exposed connectors to disconnect speed control harness.
4. If speed control harness is to be replaced, disassemble the control head as outlined in paragraph 3-21, and disconnect speed control harness from individual control head switches.

5. If steering arm wiring harness is to be replaced, remove service cover, and disconnect the wiring harness connector at the base of the steering arm.

CAUTION Incorrect wiring connections will impair lift truck performance. Carefully label or otherwise note individual wire destinations.

6. If main wiring harness is to be replaced, make note of the main wiring harness individual wire destinations and disconnect and remove the main wiring harness. Remove screw and clamp.

7. Reassemble with new wiring harness(es) installed by reversing the disassembly procedure.

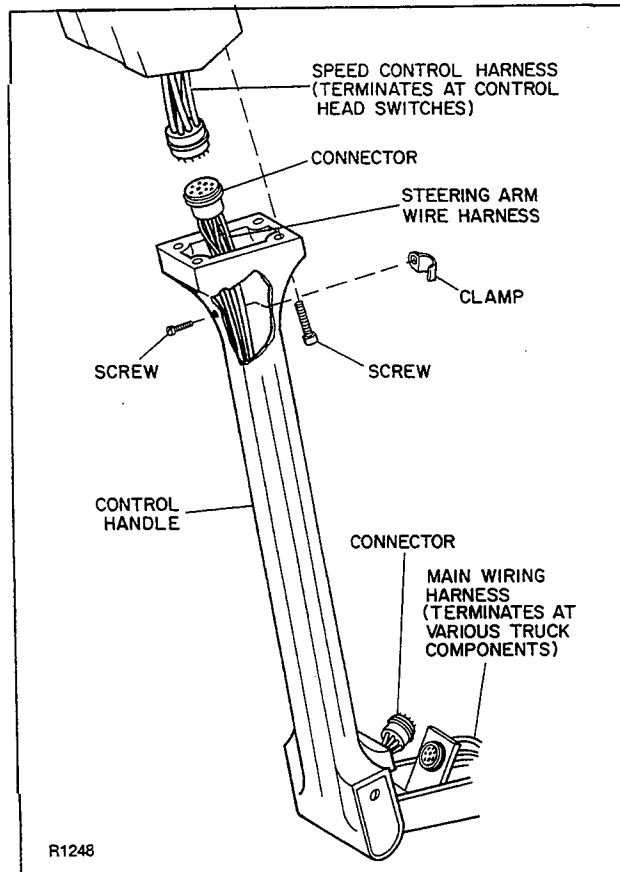

Figure 3-14. Control Shaft Cable Replacement

3-23. Grab Handle Cable Replacement. (Figure 3-15)

1. Disconnect battery.
2. Remove switch cover, switches, and pushbuttons as outlined in paragraph 3-10.
3. Disconnect the terminals of the cable assembly from the terminal block.
4. Slide the cable through the body of the grab handle.
5. Unsolder the cable wires from the terminal studs on the switches noting the wire numbers that are connected to each of the five switches.
6. Install a new grab handle cable by following steps 1 through 5 in reverse order, making sure to match the wire numbers of the quick disconnect terminals with those on the terminal block and to match the wire numbers with those on the switches as noted during disassembly.

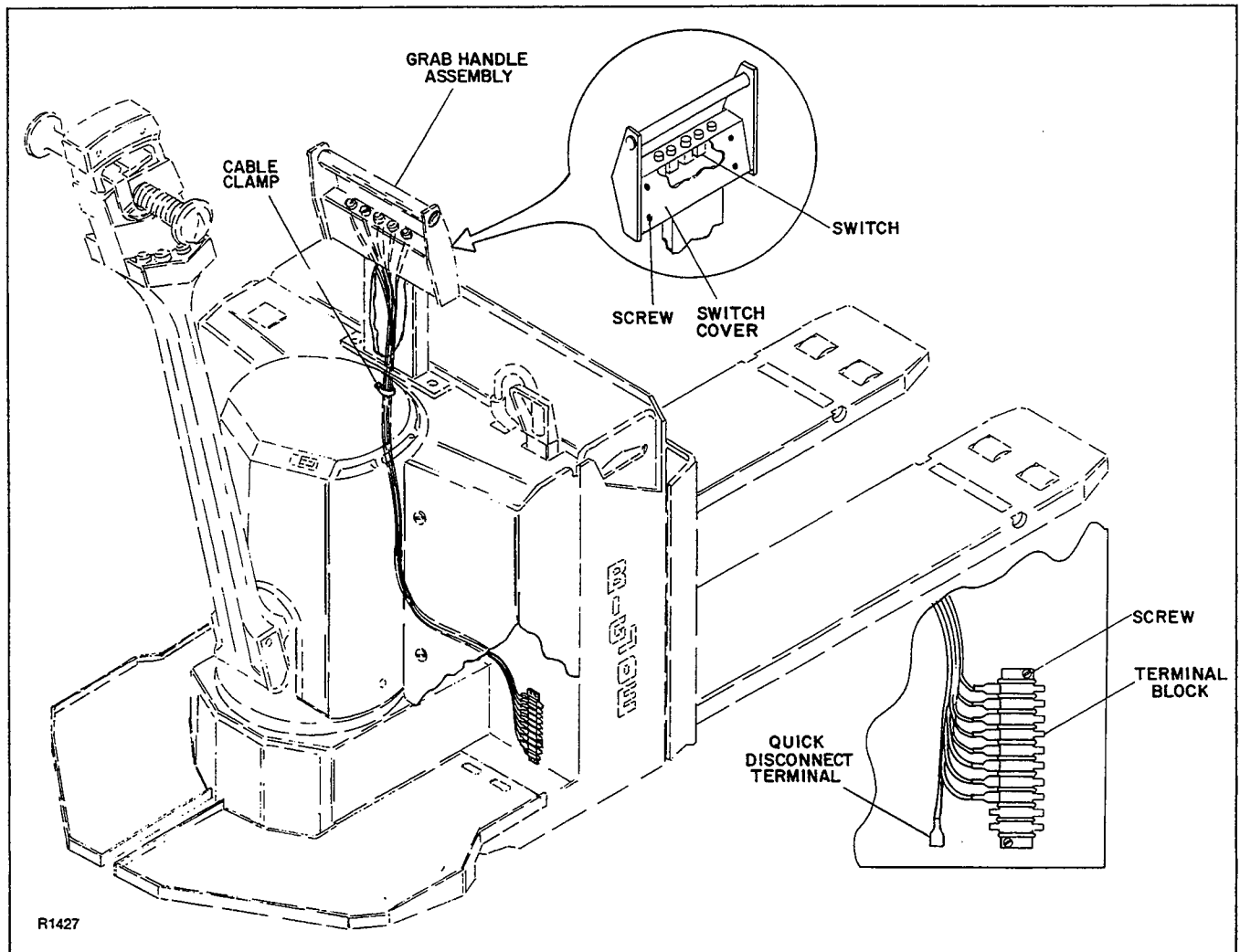

Figure 3-15. Grab Handle Cable Replacement

3-24. Drive Motor Removal.

If the motor is to be disassembled, remove it from the transmission as follows:

1. Disconnect battery.
2. Remove brake unit by removing pads (paragraph 3-11b).
3. Make sure the four cables to the drive motor are properly labeled A1, A2, F1, and F2; then disconnect the cables from the drive motor.
4. Remove the five socket head cap screws and lock washers which secure the motor to the transmission housing.
5. Transfer motor and attached brake parts to suitable workbench.
6. Continue disassembly of motor, using figure 3-16 as a guide.

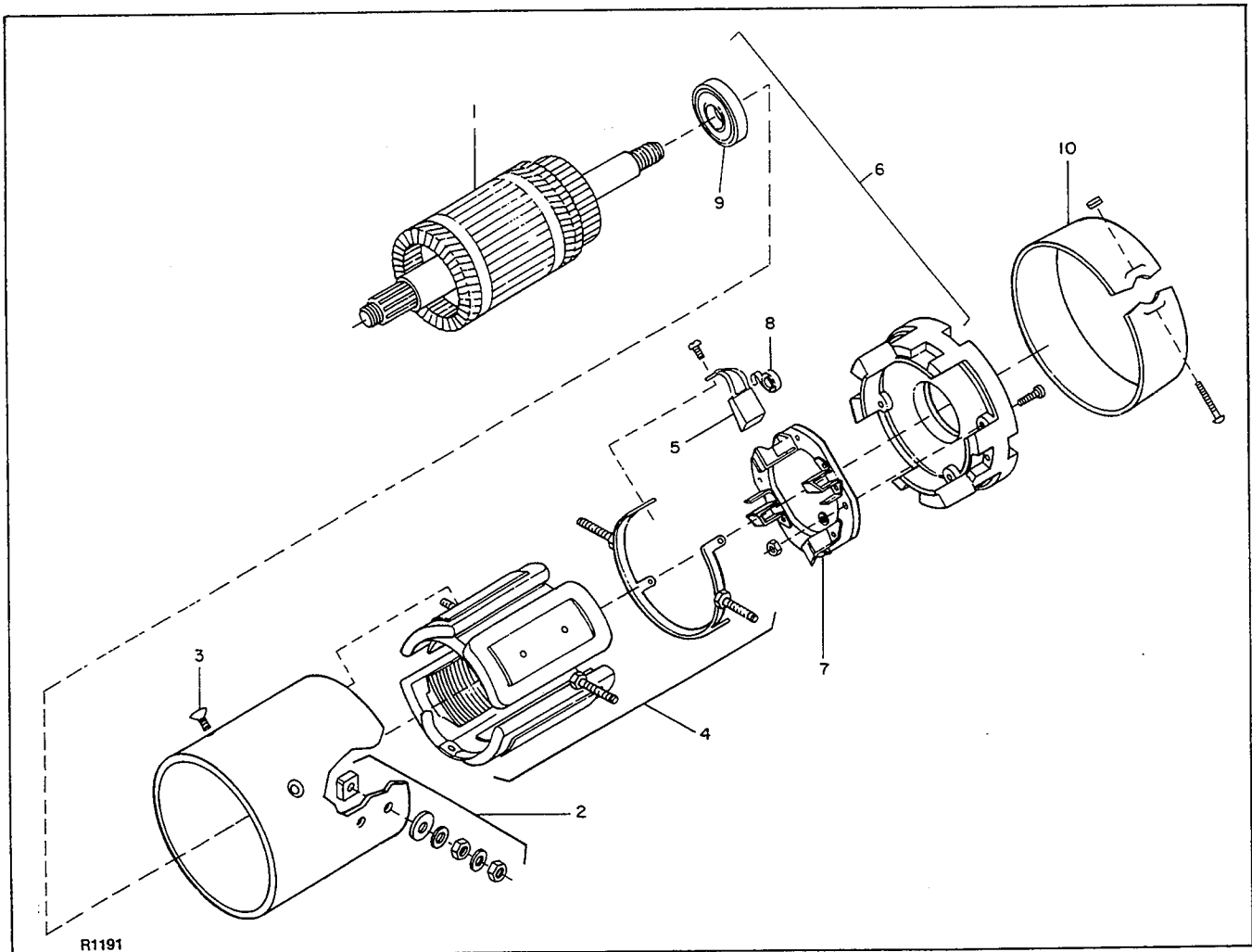

Figure 3-16. Drive Motor

12 VOLT MOTOR

24 VOLT MOTOR

INDEX NO.	PART NO.	PART NAME	NO. REQD.
	016001	Drive Motor, 12-Volt	1
1	900857	Armature	1
2	900133	Terminal Stud Package (Hdwe. Incl.)	1
3	900859	Pole Shoe Screw Package	1
4	900134	Field Coil Package	1
	---	Insulation, Field Connection	1
	---	Connector and Stud Assembly	1
	---	Connector and Stud Assembly	1
	---	Stud, Hex. Hd., 5/16-18	2
5	900787	Brush Set, Service	1
6	900788*	Head Assembly, Commutator End	1
7	900559	Brush Holder Kit	1
8	900953	Spring Set, Brush	1
9	051161	Bearing, Ball, Sealed	1
10	900954	Band, Cover	1
11	900783	Cable Tie Package	1
12	900860	Nut and Washer Package, Armature	1

INDEX NO.	PART NO.	PART NAME	NO. REQD.
	016000	Drive Motor, 24-Volt	1
1	900858	Armature	1
2	900133	Terminal Stud Package (Hdwe. Incl.)	1
3	900859	Pole Shoe Screw Package	1
4	900790	Field Coil Package	1
	---	Insulation, Field Connection	1
	---	Connector and Stud Assembly	1
	---	Connector and Stud Assembly	1
	---	Stud, Hex. Hd., 5/16-18	2
5	900791	Brush Set, Service	1
6	900792*	Head Assembly, Commutator End	1
7	900955	Brush Holder Kit	1
8	900188	Spring Set, Brush	1
9	051161	Bearing, Ball, Sealed	1
10	900954	Band, Cover	1
11	900783	Cable Tie Package	1
12	900860	Nut and Washer Package, Armature	1

* Includes retainer (Truarc #N5002-244)

* Includes retainer (Truarc #N5002-244)

3-25. Drive Motor Repair. (Figure 3-16)

The drive motor requires no periodic maintenance. However, in case the truck does not move and the drive motor is at fault, test procedures have been devised to isolate the problem to the brushes, brush springs, commutator, field coil, and/or armature. Disconnect the battery; remove drive motor cover band; and inspect brushes, brush springs, and commutator.

a. Cleaning.

1. Prior to any testing or inspection, clean the motor components, except bearings and armature, with a good grade petroleum base cleaning solvent and dry with compressed air.
2. Use compressed air to remove brush dust and dirt from around the commutator and windings of the armature.

CAUTION Never submerge bearings in a solvent. Submerging bearings in solvent will deteriorate internal lubrication which cannot be replaced.

3. Wipe bearings clean with a clean, lint-free cloth.

b. Brushes.

Brushes should have a maximum length of 1.38 inches and a minimum length of 0.57 inches. Replace brushes if length approaches the minimum value.

c. Brush Springs.

Correct brush spring tension is between 16 ounces and 36 ounces. The maximum value is for new brushes or brushes near maximum length. The minimum specified tension is for brushes near the minimum acceptable length. Measure spring tension with a spring scale hooked under the brush spring at the brush. Pull the scale on a line opposite the line of force exerted by the brush spring, and take the reading just as the spring leaves the brush.

d. Commutator.

Clean the commutator of rough spots with a fine sandpaper, and remove accumulation of loose particles. The diameter of the commutator should be checked after cleaning. If the diameter is 2.935 inches or larger, reslotting and refinishing is recommended. If diameter is less than 2.875 inches, replacement is required.

e. Electrical Measurements.

1. Measure Field Coil resistance between terminals S1 and S2 with a bridge. Resistance should be 0.0062 ohms to 0.0070 ohms.
2. The armature of the motor can be tested for shorts using a standard growler and metal strip or hacksaw blade.

3-26. Pump Motor Removal.

1. Open the left side cabinet door for access to the pump-motor-reservoir assembly.

CAUTION Incorrect reconnections of the pump motor wiring will adversely affect lift truck performance. Be sure to note and/or label all wire destinations before disconnecting.

3. Label all wires leading to the pump motor and note their destinations.
4. Electrically disconnect the pump motor.

WARNING Before disconnecting hydraulic lines, make certain that the system is not under pressure.

5. Unscrew breather cap, and drain the hydraulic oil from the reservoir into a clean bucket or suitable container.

NOTE A few feet of 1/2-inch hose will facilitate draining oil from the reservoir.

6. Remove hydraulic line from pump.
7. Remove assembly from truck by removing the screws and lock washers that secure it and its mounting bracket to the left vertical bar of the base and frame.
8. Remove pump-motor-reservoir mounting plate (20, figure 3-25) by removing the two mounting screws (19).
9. Remove reservoir (see figure 3-26) for access to the four screws that hold the motor to the pump-motor-reservoir assembly.
10. Remove the motor attaching hardware and remove motor for repair or replacement. Refer to paragraph 3-27 for motor repair procedures.
11. Install new or repaired motor by performing steps 1 through 10 in reverse sequence.

3-27. Pump Motor Repair. (Figure 3-17)

The pump motor requires no periodic maintenance. However, in case the backrest/fork does not lift and the pump motor is at fault, test procedures have been devised to isolate the problem to the brushes, brush springs, commutator, field coil, and/or armature. Disconnect the battery; remove motor cover band; and inspect brushes, brush springs and commutator. Refer to figure 3-17 as a guide to disassembly and reassembly, if required.

a. Cleaning.

1. Prior to any testing or inspection, clean the motor components, except bearings and armature, with a good grade petroleum base cleaning solvent and dry with compressed air.
2. Use compressed air to remove brush dust and dirt from around the commutator and windings of the armature.

CAUTION Never submerge bearings in a solvent. Submerging bearings in a solvent will deteriorate internal lubrication which cannot be replaced.

3. Wipe bearings clean with a clean, lint-free cloth.

b. Brushes.

Brushes should have a minimum length of 0.25 inch. Replace brushes if length approaches the minimum value.

c. Brush Springs.

Correct brush spring tension is between 32 ounces and 40 ounces. These values are for new brushes or brushes near maximum length. Measure spring tension with a spring scale hooked under the brush spring at the brush. Pull the scale on a line opposite the line of force exerted by the brush spring, and take the reading just as the spring leaves the brush.

d. Commutator.

Clean the commutator of rough spots with a fine sandpaper, and remove accumulation of loose particles. If the commutator is excessively damaged or worn, replacement of the armature or complete pump motor is recommended.

e. Armature Test.

The armature of the motor can be tested for shorts using a standard growler and metal strip or hacksaw blade.

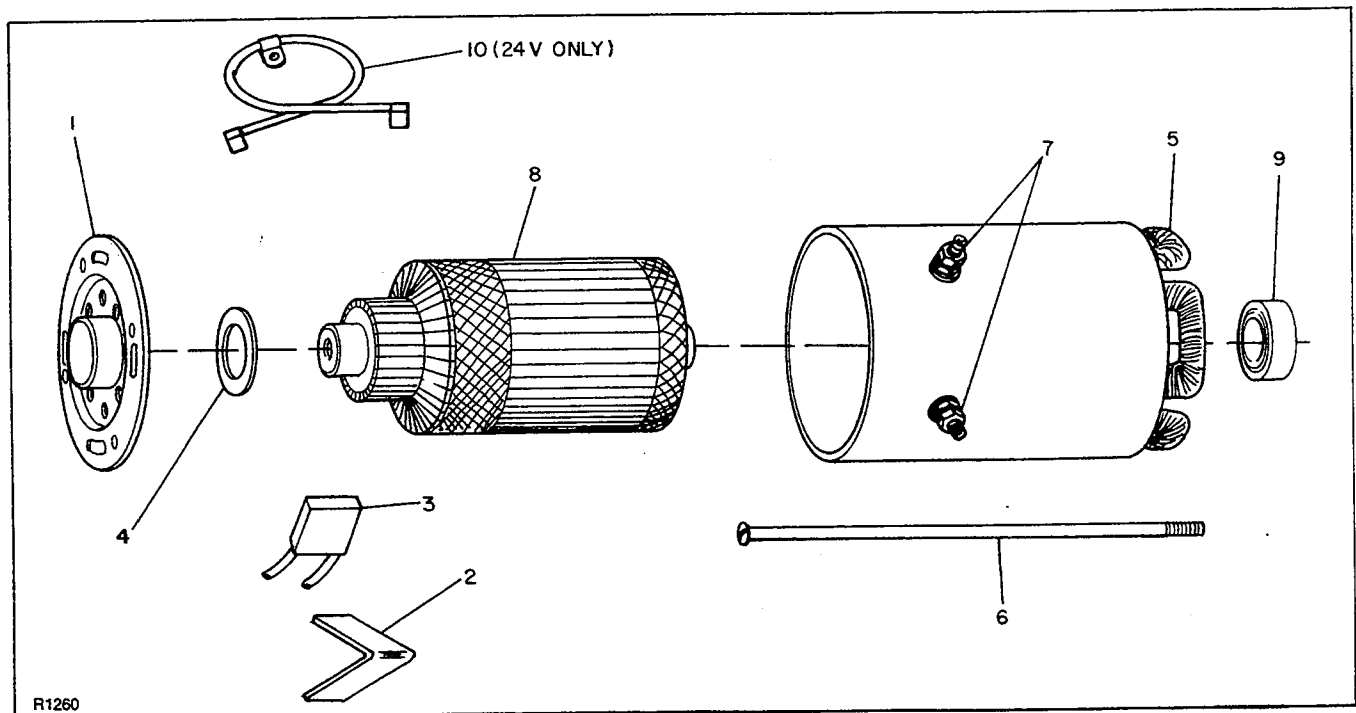

Figure 3-17. Pump Motor

12 VOLT MOTOR

INDEX NO.	PART NO.	PART NAME	NO. REQD.
1	900271	Pump Motor, 12V	1
2	009305	Commutator End Head	1
3	003501	Brush Spring & Holder Package	1
4	003702	Brush Set	1
5	900172	Thrust Washer	1
6	900171	Field Coil Package	1
7	900170	Thru Bolt Package	1
8	900173	Terminal Stud Package	2
9	001501	Armature	1
10	900495	Drive End Bearing	1

24 VOLT MOTOR

INDEX NO.	PART NO.	PART NAME	NO. REQD.
1	900426	Pump Motor, 24V	1
2	009305	Commutator End Head	1
3	003501	Brush Spring & Holder Package	1
4	003702	Brush Set	1
5	900430	Thrust Washer	1
6	900574	Field Coil Package	1
7	900432	Thru Bolt Package	1
8	900433	Terminal Stud Package	1
9	900434	Armature	1
10	900495	Drive End Bearing	1
11	900503	Lead Assembly (24V Only)	1

3-28. Electrical Control Panels.

Figures 3-18 and 3-19 locate and identify parts associated with the complete electrical control panel assemblies. Paragraphs 3-29, 3-30, 3-31, 3-32 and 3-33 cover contactor maintenance and dead-man switch maintenance.

3-29. Coil Replacement, All Contactors.

The item reference numbers used in the coil replacement text apply to figures 3-20 and 3-21 for 70- and 50-Ampere contactors.

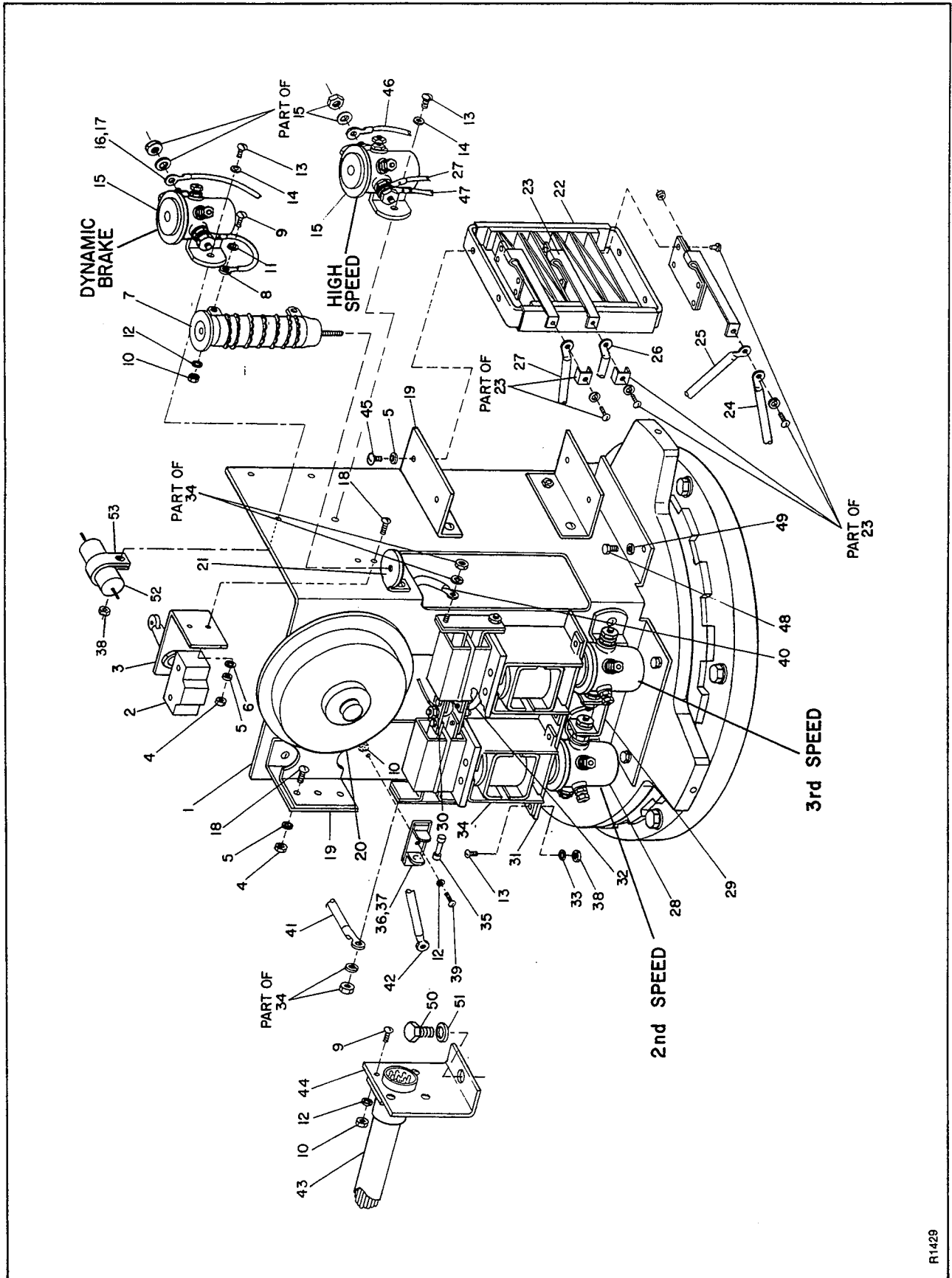

Figure 3-18. Electrical Control Panel 12V WRT-40 (Sheet 1 of 2)

INDEX NO.	PART NO.	PART NAME	PART NO.	PART NAME	NO. REQD.
27	503965-04	Cable Assembly			2
28	020419	Solenoid			2
29	401200	Bus Bar			1
30	021238	Terminal			1
31	401483	Bracket			1
32	503965-11	Cable Assembly			1
33	077208	Washer, Lock #10 Split			4
34	005638	Contact (See figure 3-20)			1
35	008910	Fuse, 15 Amp			1
36	008904	Fuse Block			1
37	056504	Decal			1
38	059416	Nut, Hex Hd. 10-32			5
39	068179	Screw, Rnd. Hd., 5-40 UNC X 5/8			1
40	503965-06	Cable Assembly			1
41	503965-25	Cable Assembly			1
42	503965-03	Cable Assembly			1
43	023092	Wire Harness			1
44	401507	Bracket, Mounting			1
45	070475	Screw, Ph. Rnd. Hd., 1/4-20 UNC X 3/8			4
46	503965-26	Cable Assembly			1
47	503965-27	Cable Assembly			1
48	063477	Screw, Hex. Cap, 1/4-20 UNC X 5/8			4
49	077209	Washer, Lock 1/4 Split			4
50	063603	Screw, Hex. Hd., 3/8-16 X 3/4			1
51	077211	Washer, Lock 3/8 Split			1
52	504066-09	Time Delay Assy-1 sec			1
53	056121	Clamp			1

INDEX NO.	PART NO.	PART NAME	NO. REQD.
1	504045	Electrical Panel Assembly, 12V	1
2	401449	Electrical Panel	1
3	020673	Dead-Man Switch	1
4	401502	Bracket	1
5	059421	Nut, Hex., 1/4-20 UNC	13
6	077209	Washer, Lock 1/4 Split	17
7	077030	Washer, Flat #10	2
8	018907	Brake Resistor	1
9	021237	Terminal	2
10	068177	Screw, Rnd. Hd., 5-40 UNC X 3/8	6
11	059410	Nut, Hex. 5-40 UNC	7
12	077007	Washer, Flat 5/32	2
13	077203	Washer, Lock #5 Split	7
14	071376	Screw, Ph. Truss Hd., 10-32 UNF X 1/2	12
15	077407	Washer, Lock Ext. Tooth, #10	8
16	020719	Solenoid	2
17	021239	Terminal	3
18	023036	Wire, #10 Ga.	A/R
19	070477	Screw, Ph. Rnd. Hd., 1/4-20 UNC X 5/8	13
20	401478	Bracket only	3
21	009600	Horn	1
22	401477	Bracket, Brake Resistor	1
23	018904	Speed Control Resistor	1
24	021221	Terminal	3
25	503965-02	Cable Assembly	1
26	503965-07	Cable Assembly	1
27	503965-05	Cable Assembly	1

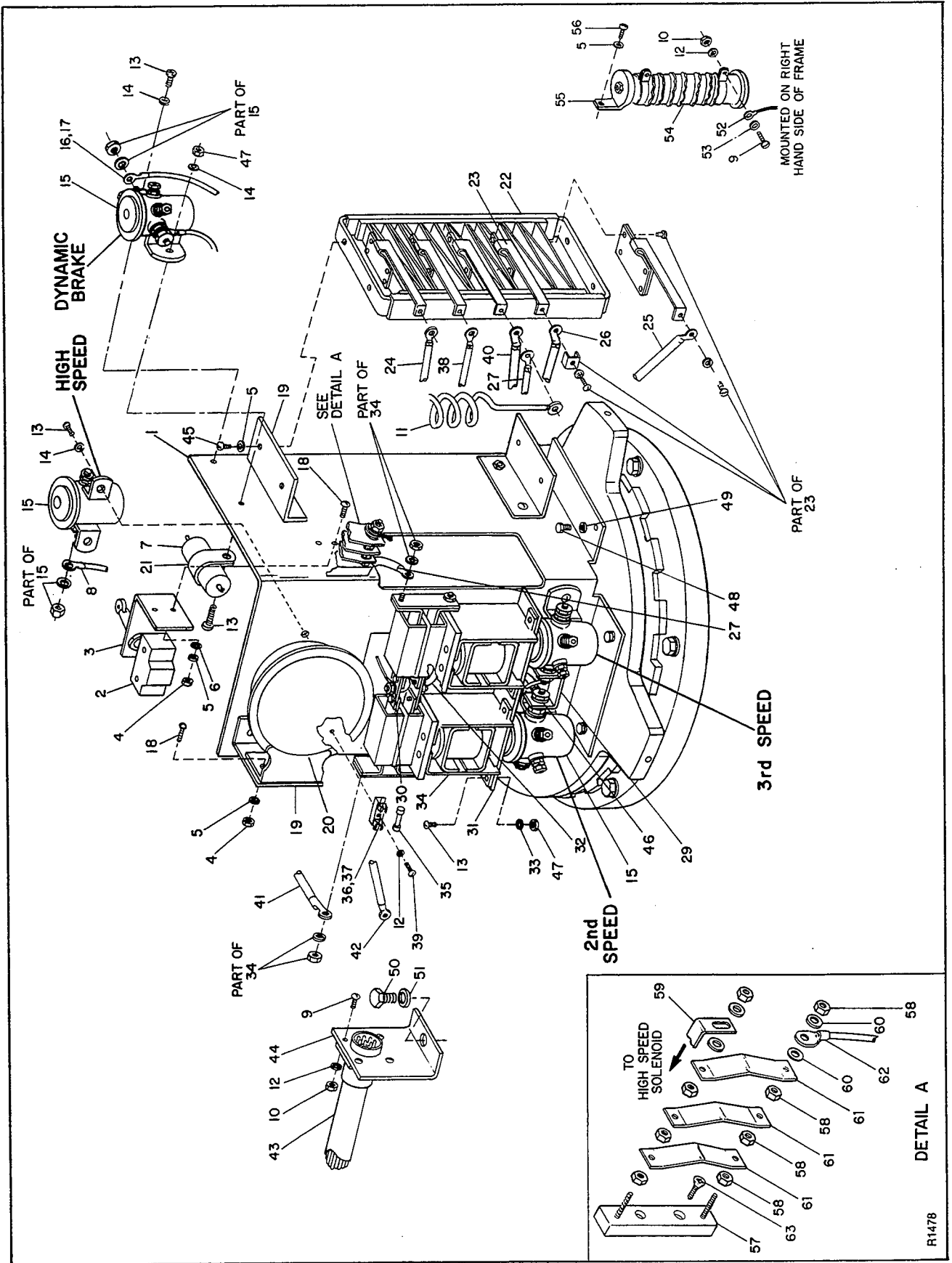

Figure 3-18. Electrical Control Panel 24V WRT-40 (Sheet 2 of 2)

INDEX NO.	PART NO.	PART NAME	NO. REQD.	INDEX NO.	PART NO.	PART NAME	NO. REQD.
1	504049	Electrical Panel Assembly, 24V	1	32	503965-11	Cable Assembly	1
2	401449	Electrical Panel	1	33	077208	Washer, Lock #10 Split	4
3	020673	Dead-Man Switch	1	34	005639	Contact (See figure 3-20)	1
4	401502	Bracket	1	35	008910	Fuse, 15 Amp	1
5	059421	Nut, Hex., 1/4-20 UNC	13	36	008904	Fuse Block	1
6	077209	Washer, Lock 1/4 Split	18	37	056504	Decal	1
7	077030	Washer, Flat #10	2	38	503965-33	Cable Assembly	1
8	504066-05	Delay Assembly, 1 Sec	1	39	068179	Screw, Rnd. Hd., 5-40 UNC x 5/8	1
9	503965-32	Cable Assembly	1	40	503965-07	Cable Assembly	1
10	068177	Screw, Rnd. Hd., 5-40 UNC x 3/8	6	41	503965-25	Cable Assembly	1
11	059410	Nut, Hex. 5-40 UNC	7	42	503965-03	Cable Assembly	1
12	023105	Coil Assembly	1	43	023103	Wire Harness	1
13	077203	Washer, Lock #5 Split	7	44	401507	Bracket, Mounting	1
14	071376	Screw, Ph. Truss Hd., 10-32 UNF x 1/2	12	45	070475	Screw, Ph. Rnd. Hd., 1/4-20 UNC x 3/8	4
15	077407	Washer, Lock Ext. Tooth, #10	8	46	503965-10	Cable Assembly	1
16	020715	Solenoid	4	47	059416	Nut, Hex. Hd. 10-32	5
17	021239	Terminal	3	48	063477	Screw, Hex. Cap, 1/4-20 UNC x 5/8	4
18	023036	Wire, #10 Ga.	A/R	49	077209	Washer, Lock 1/4 Split	4
19	070477	Screw, Ph. Rnd. Hd., 1/4-20 UNC x 5/8	13	50	063603	Screw, Hex. Hd., 3/8-16 x 3/4	1
20	401478	Bracket only	3	51	077211	Washer, Lock 3/8 Split	1
21	009602	Horn, 24V	1	52	021237	Terminal	2
22	056121	Clamp	1	53	077007	Washer	2
23	018900	Speed Control Resistor	1	54	018913	Resistor-Brake	1
24	021221	Terminal	5	55	401477	BRKT-MTG	1
25	503965-31	Cable Assembly	1	56	065476	SCR. 1/4-20 x 1/2	1
26	503965-34	Cable Assembly	1	57	008902	Fuse Block	1
27	503965-12	Cable Assembly	1	58	059428	Nut, Brass, 5/16-18	8
28	503965-06	Cable Assembly	1	59	402160	Bus Bar	1
29	401200	Bus Bar	2	60	077105	Washer, Flat, Bronze	4
30	021238	Terminal	1	61	018914	Element-Resistor	3
31	401483	Bracket	1	62	503965-02	Cable Assembly	1
				63	069478	Screw, Phillips Hd. 1/4-20 x 3/4	2

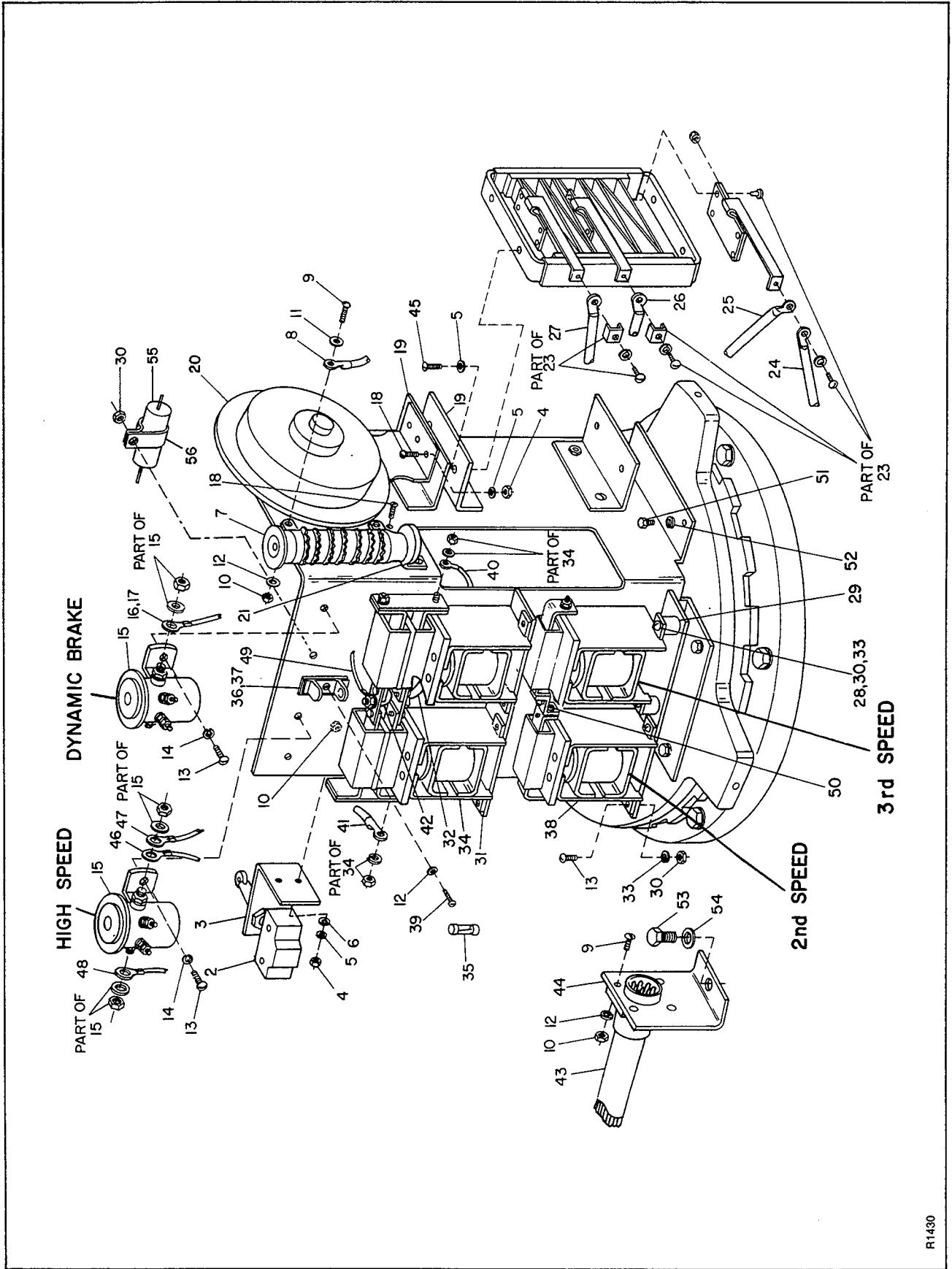

Figure 3-19. Electrical Control Panel 12V (WRT-60) (Sheet 1 of 2)

INDEX NO.	PART NO.	PART NAME	NO. REQD.
1	504047	Electrical Panel Assembly 12V	1
2	401628	Electrical Panel	1
3	020673	Dead-Man Switch	1
4	401502	Bracket	1
5	059421	Nut, Hex., 1/4-20 UNC	13
6	077209	Washer, Lock 1/4 Split	17
7	077030	Washer, Flat #10	2
8	018907	Brake Resistor	1
9	021237	Terminal	2
10	068177	Screw, Rnd. Hd., 5-40 UNC X 3/8	6
11	059410	Nut, Hex. 5-40 UNC	7
12	077007	Washer, Flat 5/32	2
13	077203	Washer, Lock, #5 Split	7
14	071376	Screw, Ph. Truss Hd., 10-32 UNF X 1/2	10
15	077407	Washer, Lock Ext. Tooth, #10	4
16	020719	Solenoid	2
17	021239	Terminal	3
18	023036	Wire, #10 Ga.	A/R
19	070477	Screw, Ph. Rnd. Hd., 1/4-20 UNC X 5/8	13
20	401478	Bracket only	3
21	009600	Horn	1
22	401477	Bracket, Brake Resistor	1
23	018904	Speed Control Resistor	1
24	021221	Terminal	3
25	503965-20	Cable Assembly	1
26	503965-07	Cable Assembly	1
27	503965-21	Cable Assembly	1
28	503965-23	Cable Assembly	1
	071380	Screw	2

INDEX NO.	PART NO.	PART NAME	NO. REQD.
29	401629	Spacer	2
30	059416	Nut	9
31	401483	Bracket	2
32	503965-11	Cable Assembly	1
33	077208	Washer, Lock #10 Split	8
34	005638	Contactor (See figure 3-20)	1
35	008910	Fuse, 15 Amp	1
36	008904	Fuse Block	1
37	056504	Decal	1
38	005635	Contactor, (See figure 3-21)	2
39	068179	Screw, Rnd. Hd., 5-40 UNC X 5/8	1
40	503965-06	Cable Assembly	1
41	503965-25	Cable Assembly	1
42	503965-22	Cable Assembly	1
43	023094	Wire Harness	1
44	401507	Bracket, Mounting	1
45	070475	Screw, Ph. Rnd. Hd., 1/4-20 UNC X 3/8	4
46	503965-05	Cable Assembly	1
47	503965-29	Cable Assembly	1
48	503965-28	Cable Assembly	1
49	021238	Terminal	1
50	401630	Bus Bar	1
51	063477	Screw, Hex. Cap, 1/4-20 UNC X 5/8	4
52	077209	Washer, Lock 1/4 Split	4
53	063603	Screw, Hex. Hd. 3/8-16 X 3/4	4
54	077211	Washer, Lock 3/8 Split	1
55	504066-09	Time Delay Assy-1 sec	1
56	056121	Clamp	1

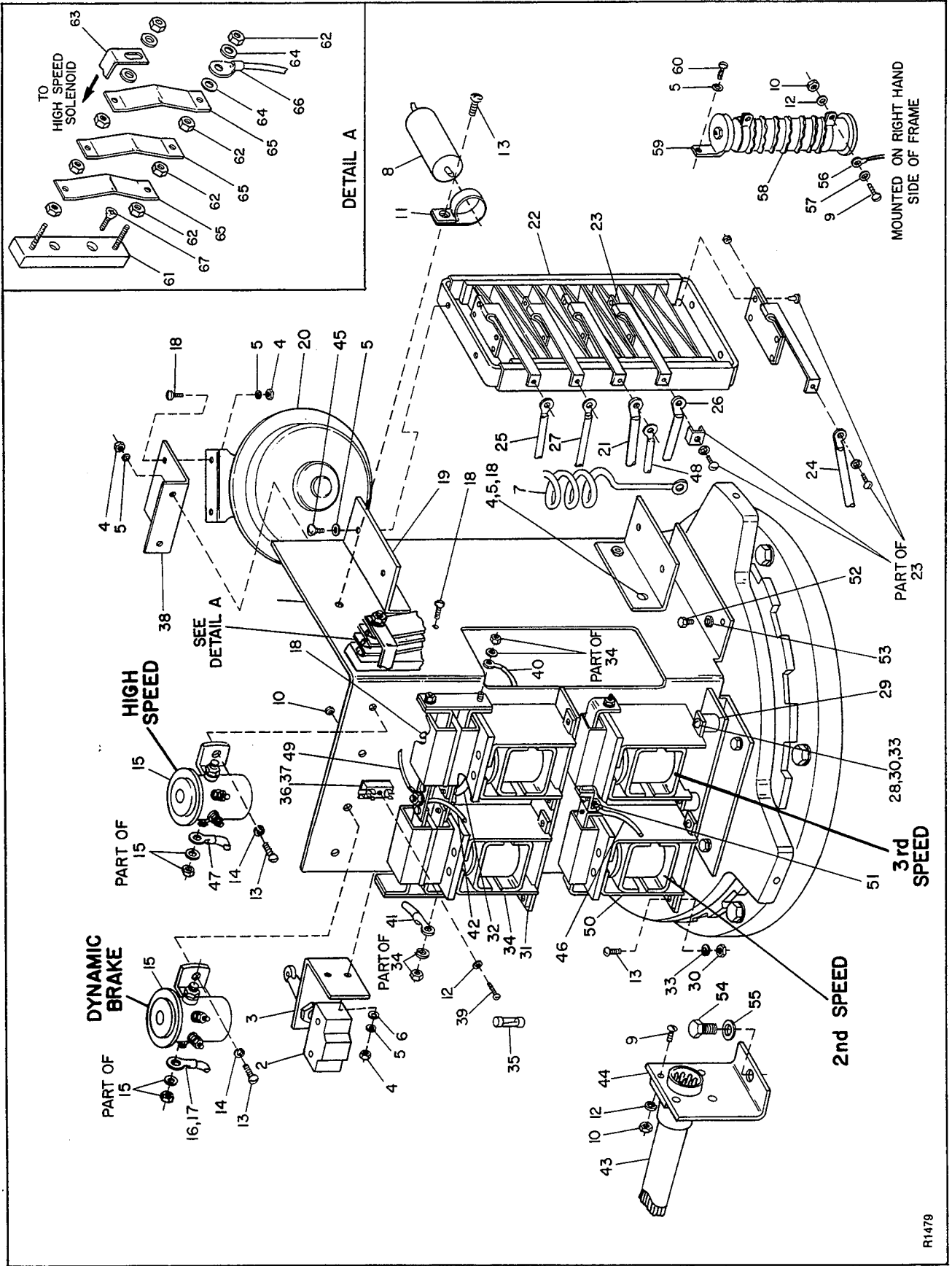

Figure 3-19. Electrical Control Panel 24V WRT-60 (Sheet 2 of 2)

INDEX NO.	PART NO.	PART NAME	NO. REQD.	INDEX NO.	PART NO.	PART NAME	NO. REQD.
1	504050	Electrical Panel Assembly, 24V	1	34	005639	Contactors (See figure 3-20)	1
2	401628	Electrical Panel	1	35	008910	Fuse, 15 Amp	1
3	020673	Dead-Man Switch	1	36	008904	Fuse Block	1
4	401502	Bracket	1	37	056504	Decal	1
5	059421	Nut, Hex., 1/4-20 UNC	14	38	401658	Bracket	1
6	077209	Washer, Lock 1/4 Split	19	39	068179	Screw, Rnd. Hd., 5-40 UNC x 5/8	1
7	077030	Washer, Flat #10	2	40	503965-06	Cable Assembly	1
8	023105	Coil Assembly	1	41	503965-25	Cable Assembly	1
9	504066-01	Delay Assembly, 1 Sec	1	42	503965-30	Cable Assembly	1
10	068177	Screw, Rnd. Hd., 5-40 UNC x 3/8	6	43	023104	Wire Harness	1
11	059410	Nut, Hex. 5-40 UNC	7	44	401507	Bracket, Mounting	1
12	056121	Clamp	1	45	070475	Screw, Ph. Rnd. Hd., 1/4-20 UNC x 3/8	4
13	077203	Washer, Lock, #5 Split	7	46	503965-24	Cable Assembly	1
14	071376	Screw, Ph. Truss Hd., 10-32 UNF x 1/2	11	47	503965-35	Cable Assembly	1
15	077407	Washer, Lock Ext. Tooth, #10	5	48	503965-23	Cable Assembly	1
16	020715	Solenoid, 24V	2	49	021238	Terminal	1
17	021239	Terminal	3	50	005637	Contactors (See figure 3-21)	2
18	023036	Wire, #10 Ga.	A/R	51	401630	Bus Bar	1
19	070477	Screw, Ph. Rnd. Hd., 1/4-20 UNC x 5/8	14	52	063477	Screw, Hex. Cap, 1/4-20 UNC x 5/8	4
20	401478	Bracket only	2	53	077209	Washer, Lock 1/4 Split	4
21	009602	Horn, 24V	1	54	063603	Screw, Hex. Hd. 3/8-16 x 3/4	1
22	503965-07	Cable Assembly	1	55	077211	Washer, Lock 3/8 Split	1
23	018900	Speed Control Resistor	1	56	021237	Terminal	2
24	021221	Terminal	5	57	077007	Washer	2
25	503965-21	Cable Assembly	1	58	018913	Resistor-Brake	1
26	503965-31	Cable Assembly	1	59	401477	Brkt	1
27	503965-20	Cable Assembly	1	60	065476	SCR, 1/4-20 x 1/2	1
28	503965-33	Cable Assembly	1	61	008902	Fuse Block	1
29	071380	Screw	2	62	059428	Nut, Brass, 5/16-18	8
30	401629	Spacer	2	63	402161	Bus Bar	1
31	059416	Nut	8	64	077105	Washer, Flat, Bronze	4
32	401483	Bracket	2	65	018914	Element-Resistor	3
33	503965-11	Cable Assembly	1	66	503965-02	Cable Assembly	1
	077208	Washer, Lock #10 Split	8	67	069478	Screw, Phillips Hd. 1/4-20 x 3/4	2

CAUTION Do not remove the top frame screws. These screws are shown in parts location illustrations with an asterisk. These screws are factory set and determine the total core stroke which must not be changed.

1. Remove the four screws (5) and lock washers (6) to release end frame and core assembly (1) from the side frame (4).
2. Observe the orientation of the coil (3) to the side frame (4) for reassembly. Then slide end frame and core assembly (1) out of side frame, and remove coil (3) and O-ring (2).
3. Thoroughly check the end frame and core assembly (1) to be sure that brass tube cannot move vertically in the end frame assembly, and the teflon bearing inside is not loose, torn or folded. If there is any damage to this assembly, it should be replaced.

NOTE It is recommended that the neoprene washer (O-ring) (2) be replaced when the coil is replaced.

4. Position the coil (3) onto the brass tube of the end frame and core assembly (1) in the same orientation as the original coil with regard to terminal location and mounting screw direction, making sure the O-ring (2) is in place.
5. Slide end frame assembly with coil into the contactor side frame assembly (4) making sure the movable core assembly (9) enters the tube assembly freely, to prevent damage to the teflon tube bearing.
6. Place two 3/4-inch inside diameter nuts or equivalent over end of core as shown in figure 3-22. Then, using a C-clamp, press the end frame and core assembly (1) into position so that no movement of the coil can occur.
7. Fasten the end frame and core assembly to the side frame using four screws (5) and lock washers (6).

NOTE Coil replacement does not change contactor gap therefore no adjustment of contactor gap is required.

8. Check that coil is tightly sealed and will not move.

3-30 Contact Replacement.

a. Contactor Replacement WRT-40 and WRT-60.

The 70-Ampere Contactors contain two sets of normally open contacts and two sets of normally closed contacts and in fact comprise two contactors connected by bus bars. Contact kits are available for contact replacement. Refer to the parts list associated with figure 3-20. The following is a procedure for contact replacement.

NOTE The bus bars (32, figure 3-20) must be removed from the contactor before disassembly can proceed.

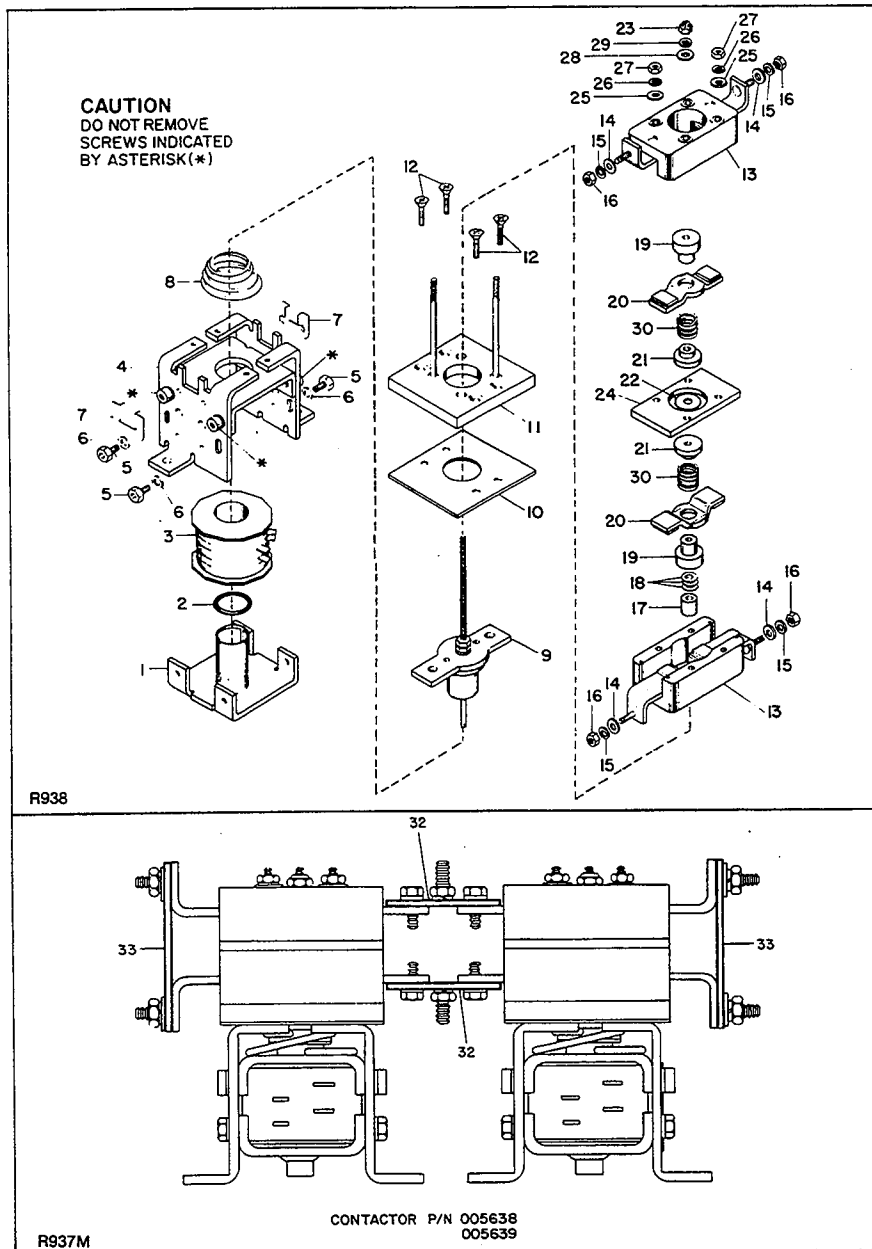

Figure 3-20. 70-Ampere Contractor (WRT-40 and WRT-60)

INDEX NO.	PART NO.	PART NAME	NO. REQD.	INDEX NO.	PART NO.	PART NAME	NO. REQD.
1	900707	Frame and Core Assembly	2	17	NP	Spacer	1
2	900708	O-ring	2	18	NP	Shims, 0.0005 inch thk.	4
3	900709	Coil, 12-Volt	2	19	NP	Bushing, Long Shoulder	1
	900710	Coil, 24-Volt	2	20	NP	Moving Bridge Assembly	1
4	900711	Side Frame	2	21	NP	Bushing, Short Shoulder	1
5	900712	Screw, Torx Hex. Hd. 8-32 x 3/8	8	22	NP	Shims, 0.0005 inch thk.	4
6	---	Washer #8 (included w/item 5)	8	23	NP	Nut, Flex Lock 6-32	2
7	900713	Operator Guide	2	24	900725	Spacer	1
8	900714	Return Spring	2	25	900726	Flat Washer, 3/8 x .156 x .049	4
9	900716	Moving Core Assembly	2	26	---	Lock Washer, #6	4
10	900718	Insulation	2	27	900727	Nut, Hex. 6-32	4
11	900719	Insulator Assembly	2	28	900726	Flat Washer, 3/8 x .156 x .049	2
12	---	Screw, Fil Hd. 8-32 x 7/16	8	29	---	Lock Washer #6	2
---	900722	Contact Kit	4	30	900723	Main Contact Spring	2
13	NP	Base and Bus Bar Assembly	1	31	---	Not Used	---
14	NP	Flat Washer #10	2	32	900728	Bus Bar Assembly	2
15	NP	Lock Washer #10	2	33	900730	Bus Bar Assembly	2
16	NP	Nut, Hex. 10-32	1				

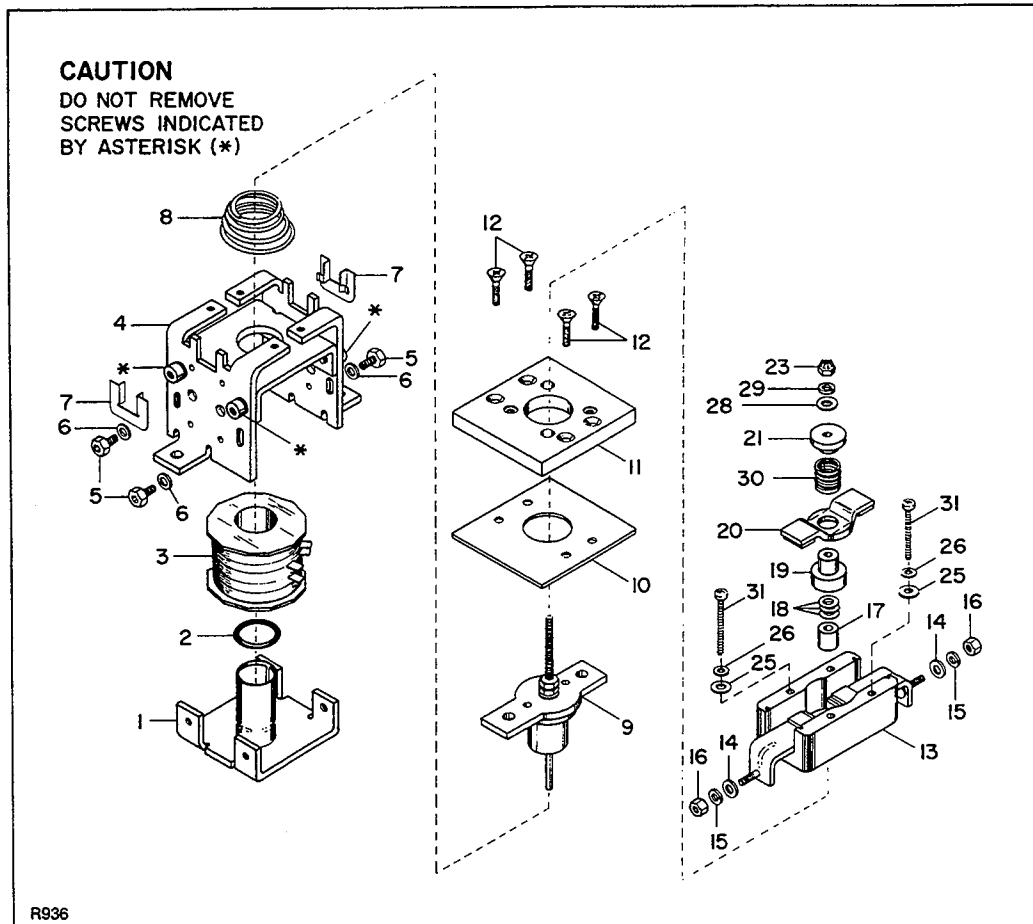

Figure 3-21. 50-Ampere Contractor (WRT-60)

INDEX NO.	PART NO.	PART NAME	NO. REQD.
1	900707	Frame and Core Assembly	1
2	900708	O-Ring	1
3	900709	Coil, 12-Volt	1
3	900710	Coil, 24 volt	1
4	900711	Side Frame	1
5	900712	Screw, Torx Hex. Hd., 8-32 x 3/8	4
6	---	Washer #8 (included w/item 5)	4
7	900713	Operator Guide	1
8	900715	Return Spring	1
9	900717	Moving Core Assembly	1
10	900718	Insulation	1
11	900720	Insulator Assembly	1
12	---	Screw, Fil Hd. 8-32 x 7/16	4
	900721	Contact Kit	1
13	NP	Base and Bus Bar Assembly	1
14	NP	Flat Washer #10	2
15	NP	Lock Washer #10	2
16	NP	Nut, Hex. 10-32	2

INDEX NO.	PART NO.	PART NAME	NO. REQD.
17	NP	Spacer	1
18	NP	Shims, 0.0005 inch thk.	4
19	NP	Bushing, Long Shoulder	1
20	NP	Moving Bridge Assembly	1
21	NP	Bushing, Short Shoulder	1
22	---	Not Used	---
23	NP	Nut, Flex Lock 6-32	1
24	---	Not Used	---
25	900726	Flat Washer, 3/8 x .156 x .049	2
26	---	Lock Washer #6	2
27	---	Not Used	---
28	900726	Flat Washer, 3/8 x .156 x .049	1
29	---	Lock Washer #6	1
30	900724	Main Contact Spring	1
31	---	Screw, Fil Hd. 6-32 x 1	2

* N.P. indicates not separately procurable. Parts must be purchased as a contactor kit.

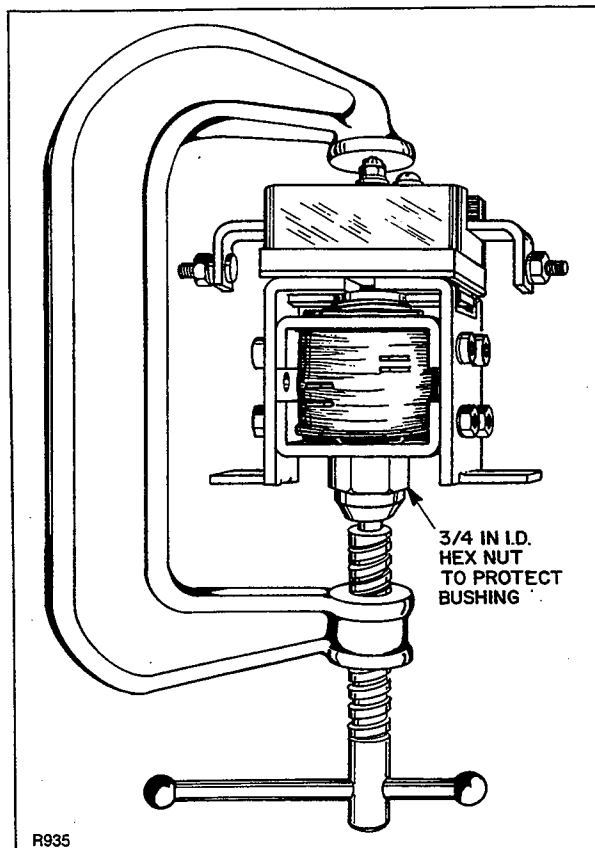

Figure 3-22. Coil and End Frame Reassembly

1. Remove the two hex nuts (27), lock washers (26) and flat washers (25).
2. Lift off upper bus bar assembly (13).
3. Remove flex lock nut (23), lock washer (29) and flat washer (28).
4. Remove top long shoulder bushing (19), bridge (20), spring (30), and top short shoulder bushing (21).
5. Remove spacer (24), and normally closed contact shims (22). Note the number of shims used.
6. Remove bottom short shoulder bushing (21), spring (30), lower bridge assembly (20), lower bus bar assembly (13), and lower long shoulder bushing (19).

NOTE Do not remove shims (18) or spacer (17).

7. To reassemble use the contact kits specified in the parts list.
8. Mount lower bus bar assembly (13) on studs (contact surfaces up).
9. Place lower long shoulder bushing (19) (face up). Then place bridge assembly (20), spring (30) and lower short shoulder bushing (21)(face down) on threaded rod.
10. Place spacer (24), shims (22), upper short shoulder bushing (21)(face up), spring (30), contact bridge (20) and upper long shoulder bushing (19) (face down) on threaded rod.

NOTE Use a standard 6-32 nut to secure bushing stack for contact gap adjustment.

11. Fasten upper bus bar assembly (13) (contact side down) with two flat washers (25), lock washers (26) and hex nuts (27).

12. Check gap on N.O. lower contacts. Gap should be 0.120 inch \pm 7%.

NOTE If gap is correct the number of shims (18) must be varied. To increase gap add shims and to decrease gap remove shims.

13. Depress moving coil contact assembly (9) so that lower normally open contacts are closed. Check gap of the upper normally closed contacts. Gap should be 0.120 inch \pm 7%.

NOTE If gap is incorrect the number of shims (22) must be varied. To increase gap remove shims and to decrease gap add shims.

14. After setting gap for both the normally open and normally closed contacts, remove the 6-32 nut securing the stack, and replace with flat washer (28), lock washer (29) and flex lock nut (23).

15. Reinstall bus bars (32 and 33).

b. Contact Replacement WRT-60 Only.

Figure 3-21 illustrates the 50-ampere contactor used on the WRT-60. This is a single pole normally open contactor and requires one contact kit. The kit contains all parts required for replacement of contacts. Refer to the parts list for kit part numbers.

1. Remove two screws (31), lock washers (26) and flat washers (25) holding bus bar assembly (13) to the contactor.

2. Remove flex lock nut (23), lock washer (29), flat washer (28), short shoulder bushing (21), spring (30), bridge (20) and long shoulder bushing (19).

NOTE Do not remove shims (18) or spacer (17).

3. To reassemble use the contactor kit shown in the parts list.

4. Place long shoulder bushing (19)(facing up) on core assembly threaded rod.

5. Mount bus bar assembly (13) with two screws (31), flat washers (25) and lock washers (26).

6. Place bridge assembly (20), spring (30), and short shoulder bushing (21)(facing down) on threaded rod.

NOTE Secure bushing stack on threaded rod with a standard 6-32 hex nut for checking contact gap.

7. Check contact gap for 0.120 inch \pm 7%. If gap is incorrect it is adjustable by using more or less shims (18). To increase gap add shims and to decrease gap remove shims. Each shim changes the gap by about 0.005 inch.
8. After setting proper gap remove the 6-32 hex nut from the threaded rod and replace with the flat washer (28), lock washer (29) and flex lock nut (23).
9. Check mechanical operation of contactor. There should be no binding of movable contact assembly.
10. Check that pickup point is at 50% or less of rated voltage.

3-31. Core or Return Spring Replacement.

NOTE The item reference numbers used in the text apply to figures 3-20 and 3-21 for 70- and 50-Ampere Contactors.

Under normal circumstances it should not be necessary to replace the core (9) or return helper spring (8). If the core or return spring is damaged and requires replacement proceed as follows:

1. Remove contact assemblies as described in paragraph 3-30.
2. Remove four screws (12), insulator assembly (11), and insulation (10).
3. Core assembly (9) can now be lifted out and return spring (8) can be removed.
4. Reassemble by reversing disassembly procedure.

NOTE When reassembling, be sure that when moving core assembly (9) is fully depressed against return spring that lower end of core assembly does not extend out of end frame and core assembly (1). Moving core is properly adjusted when it is flush with bottom of bushing in end frame and core assembly (1). This is adjustable by loosening the hex nuts on the moving core assembly and adjusting threaded rod in or out as necessary, then retightening hex nuts.

3-32. Dead-Man Switch Adjustment. (Figure 3-23)

Built into each lift truck is a dead-man switch that turns off the power when the steering arm is released and allowed to return to an upright position. Actuated by a cam linked to the steering arm, the dead-man switch must be kept in proper adjustment for safe, efficient operation.

1. Remove service cover.
2. Actuate the steering arm from the horizontal position to the vertical position, and observe the action of the microswitch roller on the surface of the cam.

NOTE The microswitch is closed, allowing the truck to receive power from its battery when the roller contacts the cam at the raised area.

3. Check that the microswitch roller rides on the raised portion of the cam only when the steering arm is moved through the normal operating range as shown in figure 2-3.
4. To adjust the cam position on the shaft, loosen the two screws (figure 3-23) so the cam can be rotated.
5. Rotate the cam so that the microswitch roller lands at the middle of the raised area when the steering arm is held at a 45° angle.
6. Tighten the two screws loosened in step 4.

NOTE If the microswitch roller fails to contact the cam or fails to actuate (a distinct click should be heard) as the roller rides on and off the raised area, the position of the microswitch must be adjusted.

7. If the microswitch position must be changed, loosen the hex nuts and move the microswitch toward the cam as necessary, and tighten the hex nuts against the bracket.
8. Reinstall the service cover, and check the dead-man switch operation in a safe, obstacle-free area, moving the steering arm through its normal operating range.
9. Repeat the procedure if the dead-man switch fails to actuate, shutting off the power as shown in figure 2-3.

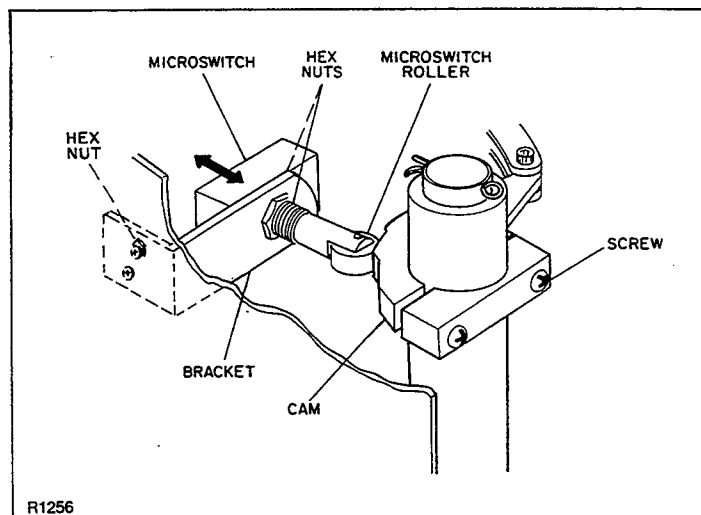

Figure 3-23. Dead-Man Switch Adjustment

3-33. Battery Connector Group Replacement.

The battery connector group makes it possible to quickly disconnect the entire electrical circuitry from the battery by means of the quick-disconnect plug. Refer to figure 3-24 for location and replacement of parts in this group.

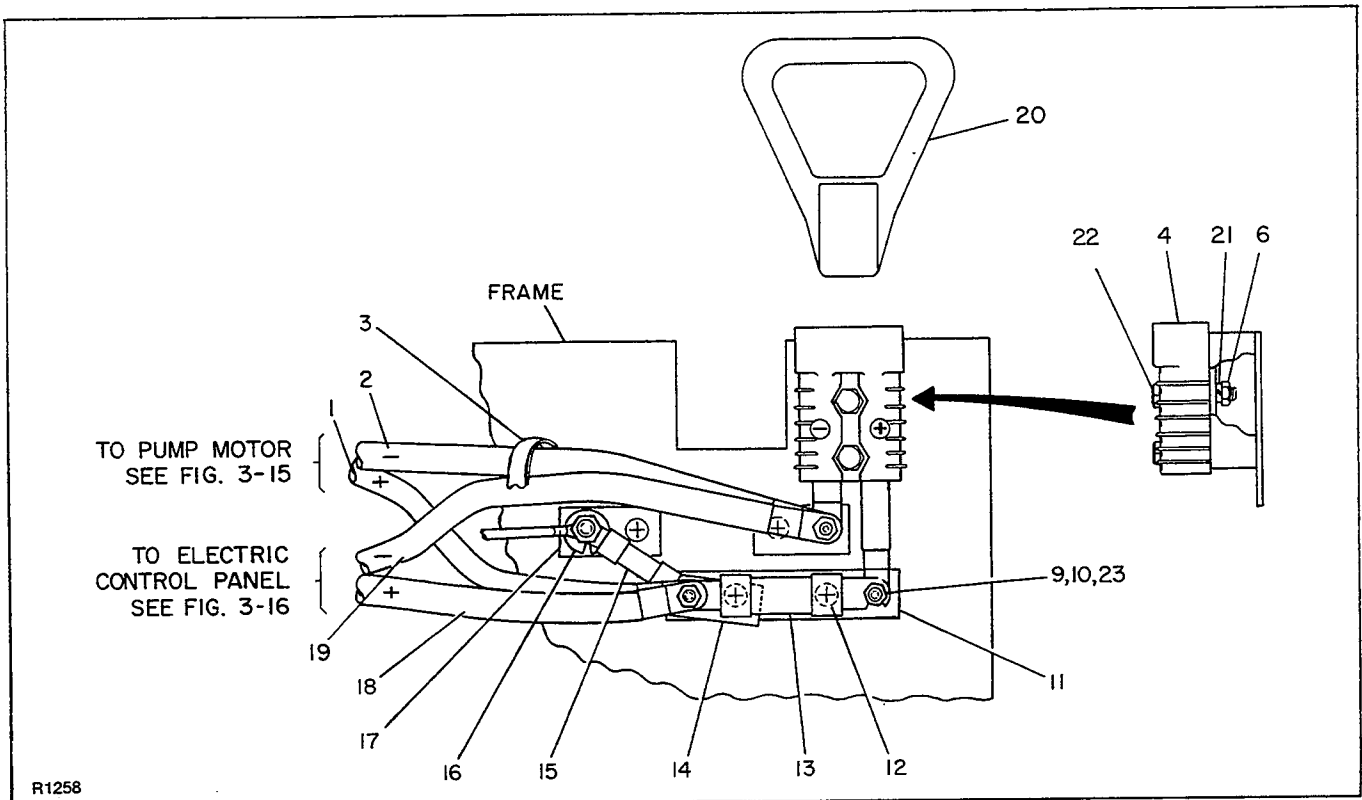

Figure 3-24. Battery Connector Group

INDEX NO.	PART NO.	PART NAME	NO. REQD.
1	503965-08	Cable Assembly, Positive	1
2	503965-09	Cable Assembly, Negative	1
3	056128	Spiroband Cable Tie	A/R
4	005400	Connector	1
5	069484	Screw, 1/4-20 X 1-1/2, Fl. Hd.	2
6	059421	Nut, Hex., 1/4-20	2
7	283700	Wire, #2 AWG.	A/R
8	021217	Terminal	2
9	059428	Nut, Brass, 5/16-18	8
10	077105	Washer	11
11	008902	Fuse Block	1
12	069478	Screw, 1/4-20 X 3/4, Fl. Hd.	4
13	008906	Fuse, 300A	1
14	056507	Label, Fuse, 300A	1
15	008917	Fuse, 40A	1
16	056515	Label, Fuse, 40A	1
17	800069	Fuse Block	2
18	503965-11	Cable Assembly Positive	REF
19	503965-10	Cable Assembly Negative	REF
20	005404	Battery Connector	1
21	077209	Lockwasher	4
22	063483	Screw	4
23	077210	Washer, Lock 5/16	4

3-34. Hydraulic System.

Paragraphs a, b and c cover the hydraulic system, the hydraulic pump-motor-reservoir assembly, the lift cylinders, and all associated parts. Also included are parts lists and illustrations to facilitate identification and location of the hydraulic system parts.

a. Hydraulic Pump-Motor-Reservoir Assembly. (Figure 3-26)

The hydraulic pump-motor-reservoir assembly may be repaired. The motor can be rebuilt, but a defective pump has to be replaced as a complete unit. Refer to figure 3-17 for breakdown of motor. Proceed as follows to remove and disassemble hydraulic pump-motor-reservoir assembly:

NOTE All new replacement pumps have SAE ports. When replacing a pump with an NPT port use adapter part number 025535.

1. Lower backrest/fork fully and disconnect battery.

WARNING Before disconnecting hydraulic lines, make certain that the system is not under pressure.

2. Open left cabinet door.
3. Unscrew breather cap and drain the hydraulic oil from the reservoir into a clean bucket or suitable container.

NOTE A few feet of 1/2-inch hose will facilitate draining oil from the reservoir.

4. Remove hydraulic lines from pump and electric wires from motor, labeling each wire to assure proper reassembly.
5. Remove assembly from truck by removing the screws and lock washers that secure it and its mounting bracket to the frame.
6. Disassemble using figure 3-26 as a guide.

NOTE Before reassembling pump-motor-reservoir assembly, it is recommended that all O-rings and gaskets be replaced.

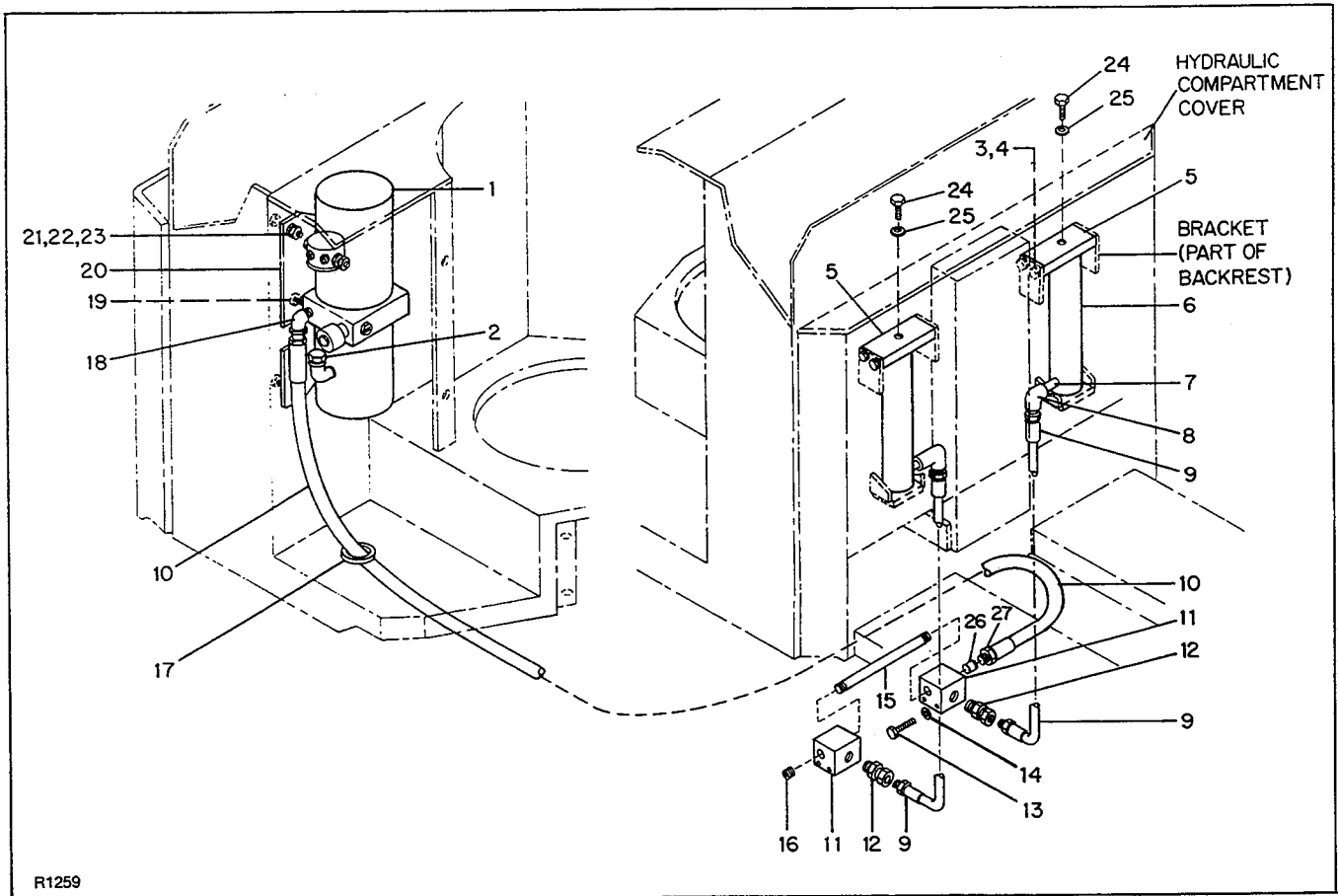

Figure 3-25. Hydraulic System

INDEX NO.	PART NO.	PART NAME	NO. REQD.
1	016582†	Pump-Motor-Reservoir, 12V (See figure 3-26)	—
—	—	1	1
1	016583†	Pump-Motor-Reservoir, 24V (See figure 3-26)	—
—	—	1	1
2	076701	Plug, Vent	1
3	064605	Screw, Hex. Cap, 3/8-16 UNC x 1	8
4	077211	Washer, Lock 3/8 Split	8
5	401479	Mounting Bar, Lift Cylinder	2
6	504007	Lift Cylinder Assembly (See figure 3-27)	—
—	—	2	2
7	026119	Pipe Nipple (Standard straddle)	2
7	402117-01	Pipe Nipple (Narrow straddle)	1
8	025505	Elbow 90°, Female - Female	2
9	503966-01	Hose Assembly, Cylinder, 12V	2
9	503966-02	Hose Assembly, Cylinder, 24V**	2
10	503964	Hose Assembly, Pressure	1
11	401500	Manifold	2
12	025107	Swivel Connector, Straight Male	2
13	063478	Screw, Hex. Cap, 1/4-20 UNC x 3/4	4
14	077209	Washer, Lock 1/4 Split	4
15	401501	Pipe Nipple (Standard straddle)	1
15	402117-03	Pipe Nipple (Narrow straddle)	1
16	026310	Plug, 3/8 NPT	1

INDEX NO.	PART NO.	PART NAME	NO. REQD.
17	057508	Grommet, Rubber	1
18	025523††	Elbow, 90° Male - Male (Standard straddle)	1
—	025525**	Elbow, 90° Male - Male (Narrow straddle)	1
19	069712	Screw, Socket Flat Hd., Lock, 3/8-16 UNC x 3/4	2
20	401480	Mounting Plate Pump-Motor- Reservoir	1
21	069605	Screw, Flat Hd. Ph. 3/8-16 UNC x 1	2
22	059429	Nut, Hex. 3/8-16 UNC	2
23	077211	Washer, Lock 3/8 Split	2
24	063482 Δ	Screw, Hex	2
25	077031 Δ	Washer, Flat	2
26	402117-01	Pipe Nipple (Narrow straddle)	1
27	025342	Coupling (Narrow straddle)	1

Δ Not included on earlier models.

† All new replacement pumps have SAE Ports. Adapter part number 025535 is required when used in trucks with NPT fittings.

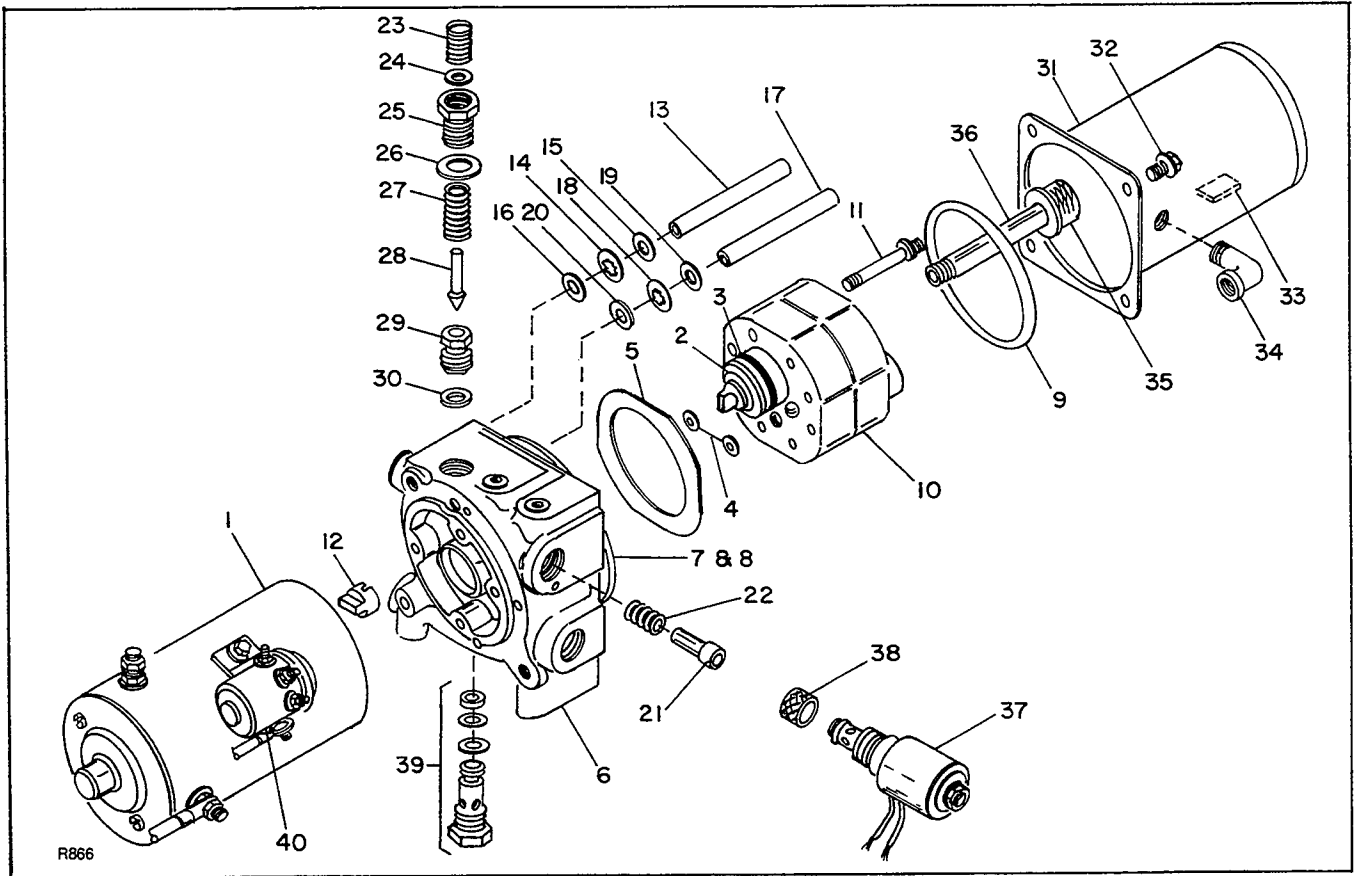

Figure 3-26. Pump-Motor-Reservoir Assembly

INDEX NO.	PART NO.	PART NAME	NO. REQD.	INDEX NO.	PART NO.	PART NAME	NO. REQD.
—	016582†	Pump-Motor-Reservoir Assembly, 12V	—	19	—	Washer	1
—	016583 †	Pump-Motor-Reservoir Assembly, 24V	—	20	—	O-ring	—
1	900271	Pump Motor, 12V (See fig. 3-17)	REF	—	900828	Flow Regulator Kit	1
1	900426	Pump-Motor, 24V (1, fig. 3-17)	REF	21	—	Flow Control Spool	1
	900682	Pump Seal Kit	1	22	—	Spring	1
2	—	Oil Seal	1	—	900692	Relief Valve Kit	1
3	—	O-ring	1	23	—	Adjusting Screw	1
4	—	O-ring	2	24	—	O-ring	1
5	—	Gasket	1	25	—	Nut, Hex. Cap	1
—	900683	Adapter Kit	1	26	—	Gasket	1
6	—	Adapter	1	27	—	Spring	1
7	—	Retainer	1	28	—	Plunger	1
8	—	Screw	2	29	—	Relief Valve Seat	1
9	—	O-ring	1	30	—	O-Ring (Relief Valve Seat)	1
—	900802	Pump Kit	1	31	900693	Reservoir	1
4	—	O-ring	1	32	900694	Screw, Hex. Hd. Thread Forming, 1/4-20 x 3/8	—
5	—	Gasket	2	—	—	—	6
10	—	Pump	1	33	900279	Magnet	1
11	—	Screw	4	34	026703	Street Elbow	1
12	—	Coupling	1	35	900270	Strainer (Reservoir)	1
—	900685	By-Pass Tube Assembly	1	36	026129	Nipple, 3/8 Pipe 5 in. Long (Inlet)	1
13	—	Return Tube	1	37	900700	12-Volt Solenoid Release Valve	1
14	—	Push On Ring	1	37	900731	24-Volt Solenoid Release Valve	1
15	—	Shim	1	38	900273	Solenoid Strainer	1
16	—	O-ring	1	39	900695	Check Valve Assembly	1
—	900686	Return Tub Assembly	1	40	020719	Solenoid, 12 V Pump Motor	1
17	—	Return Tube	1	40	900533	Solenoid, 24V Pump Motor	1
18	—	Push On Ring	1				

†All new replacement pumps have SAE Ports. Adapter part number 025535 is required when used in trucks with NPT fittings.

b. Lift Cylinder Removal. (Figure 3-25)

In order to perform the following procedures, the truck must be placed in a service position, either securely held off the floor, or carefully tipped on its side. If proper hoists or jacks are available, lower the forks as far as they will go, raise the truck off the floor and proceed with the service.

1. Place truck in service position. If tipping the truck is necessary, perform the following.
 - (a) Lower the forks all the way, and then disconnect and remove batteries.
 - (b) Plug the hydraulic reservoir breather vent with 3/8 NPT pipe plug.
 - (c) Disconnect the high-pressure hydraulic hose at the pump and place the free end of hose in a clean container to catch the oil that may drain from lift cylinders.
 - (d) Carefully tip truck onto its side.
2. Disconnect the hydraulic hose (9) where it joins swivel connector (12) under the battery compartment.
3. Remove truck from service position and set on floor.
4. Slightly raise the backrest/fork.
5. Install jacks or other supports beneath each fork.
6. Remove the two screws that fasten the hydraulic compartment cover to the truck, and remove the hydraulic compartment cover.

WARNING Before disconnecting any hydraulic lines, make sure the system is not under pressure.

7. Remove lock washers and screws (3 and 4, figure 3-25) from the backrest/fork brackets nearest the lift cylinder that is to be removed. Remove the mounting bar (5).
8. Lift out the lift cylinder.
9. Repeat the procedure for the remaining lift cylinder if both lift cylinders are to be removed.
10. To install a repaired or new lift cylinder, follow steps 1 through 7 in reverse sequence.

c. Disassembly of Lift Cylinder. (Figure 3-27)

1. Secure lift cylinder barrel in a vise.
2. Unsnap and remove internal snap ring (1) from the cylinder tube weldment (10).
3. Extract the cylinder rod (4) and attached parts from the cylinder tube weldment.

CAUTION Use proper pipe clamp vise with non-marring jaws to prevent damaging the finish of the rod.

NOTE Use parts in rebuilding kit P/N 900781 to replace items 2, 5, and 7 before reassembly.

4. Secure the cylinder rod and attached parts in a vise with non-marring jaws, and then remove wiper ring (2), gland (3), locknut (9), washer (8), U-cup piston seal (7), piston (6), and O-ring (5).

- Replace all unsatisfactory parts.

CAUTION Reassembly of the lift cylinder requires use of special tool, part number 900030, to prevent damage to cylinder packing.

- Insert special tool, part number 900030 into the end of the lift cylinder as shown in rest of figure 3-25.
- Coat rings and seal with hydraulic fluid.
- Assemble cylinder by reversing steps 1 through 4 of the disassembly procedure and removing special tool.

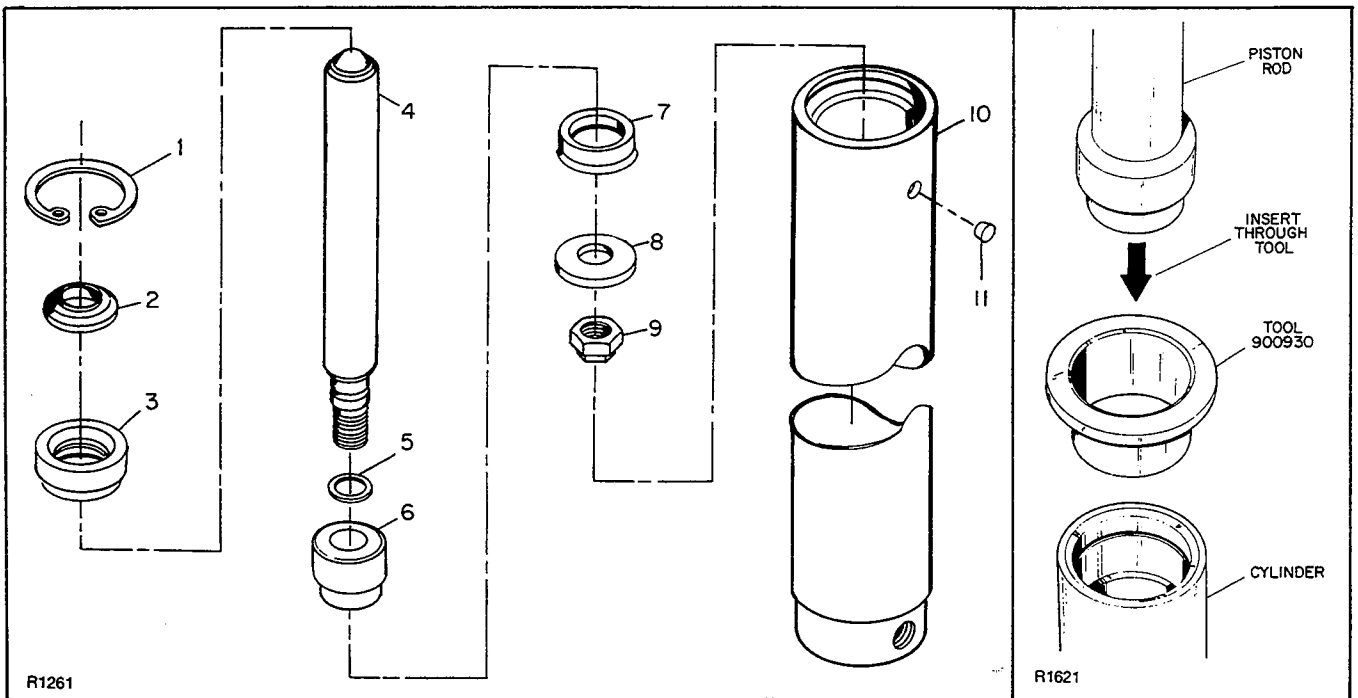

Figure 3-27. Lift Cylinder

INDEX NO.	PART NO.	PART NAME	NO. REQD.
	504007	Lift Cylinder	REF
1	061826	Snap Ring, Internal, 1.875	1
2	049500*	Ring, Wiper 1-1/4	1
3	401465	Gland	1
4	401462	Rod, Cylinder	1
5	042136*	O-Ring, 2-114	1
6	045110	Piston	1
7	043128*	Seal, Piston, U-Cup	1
8	077120	Washer, Round, Aluminum	1
9	059128	Locknut, Hexlock	1
10	504006	Tube Weldment, Cylinder	1
11	029103	Plug, Breather	1
12	900930†	Special Tool	1

* Included in Kit P/N 900781.

† Tool required for reassembly of cylinder

3-35. Skid Adapter and Load Backrest (Options)

Figure 3-28 shows the Skid Adapter and Load Backrest (inset) which can be added to the WRT Truck. These parts will augment the overall configuration and improve the fork and backrest assembly for special loads. A parts list accompanies the illustration.

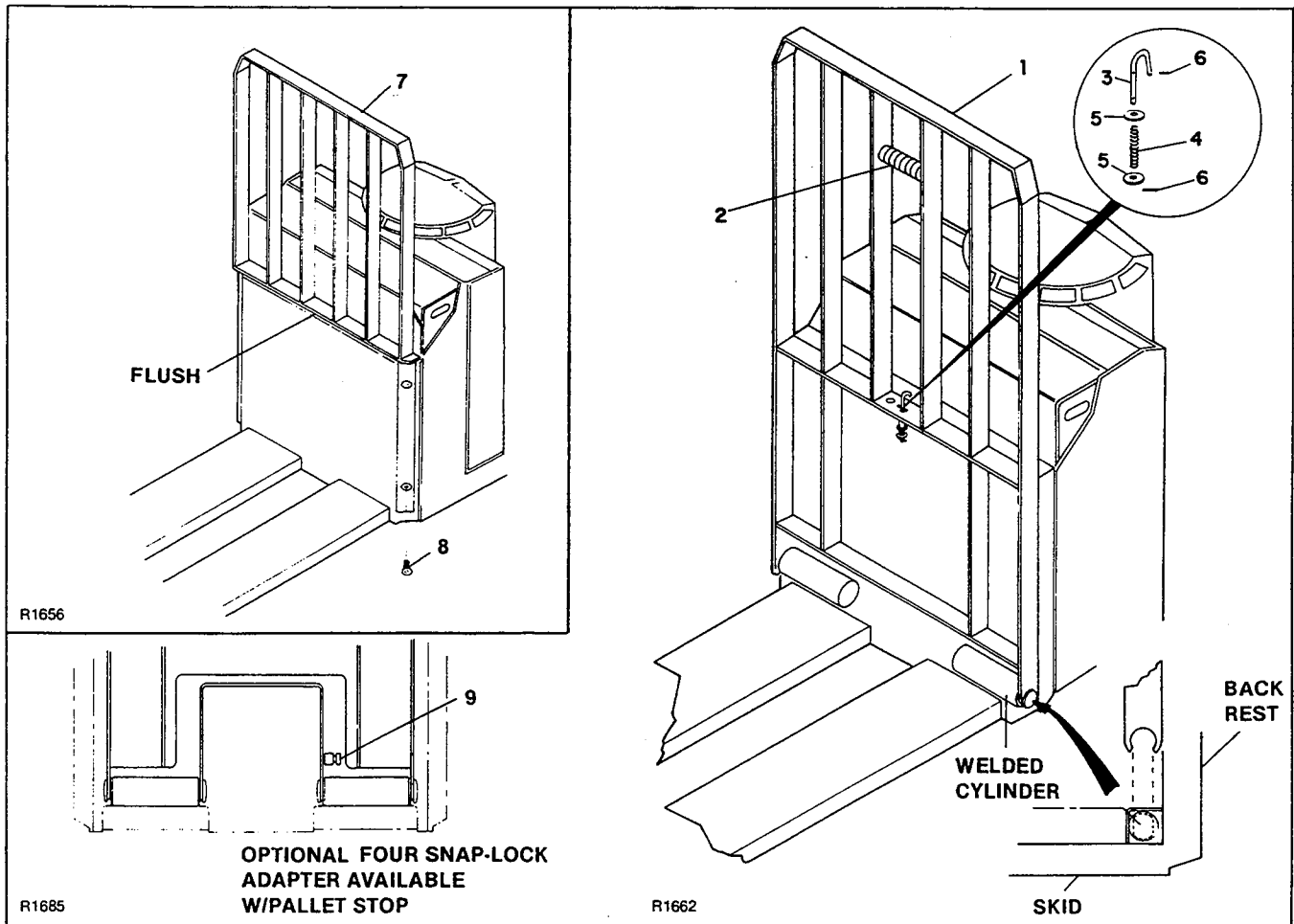

Figure 3-28. Skid Adapter and Load Backrest

INDEX NO.	PART NO.	PART NAME	NO. REQD.
1	504406	Skid Adapter	1
1	504407	Skid Adapter, w/Pallet Stop	1
2	057501	Handle	1
3	402105	Hook	1
4	402107	Spring	1
5	402108	Washer, Flat	2
6	060974	Roll Pin, 3/16 x 1-1/4	2
7	504382	Load Backrest	1
8	069706	Screw, 1/2-13 x 1	4
9	051409	Pallet Lock	1

3-36. Battery Rollout Tray (Option)

Figure 3-29 shows the Battery Rollout Tray Assembly, which can be added to the WRT Truck. This option, which comes in varying sizes, is made available to make the removal and installation of the battery easier. A parts list accompanies the illustration.

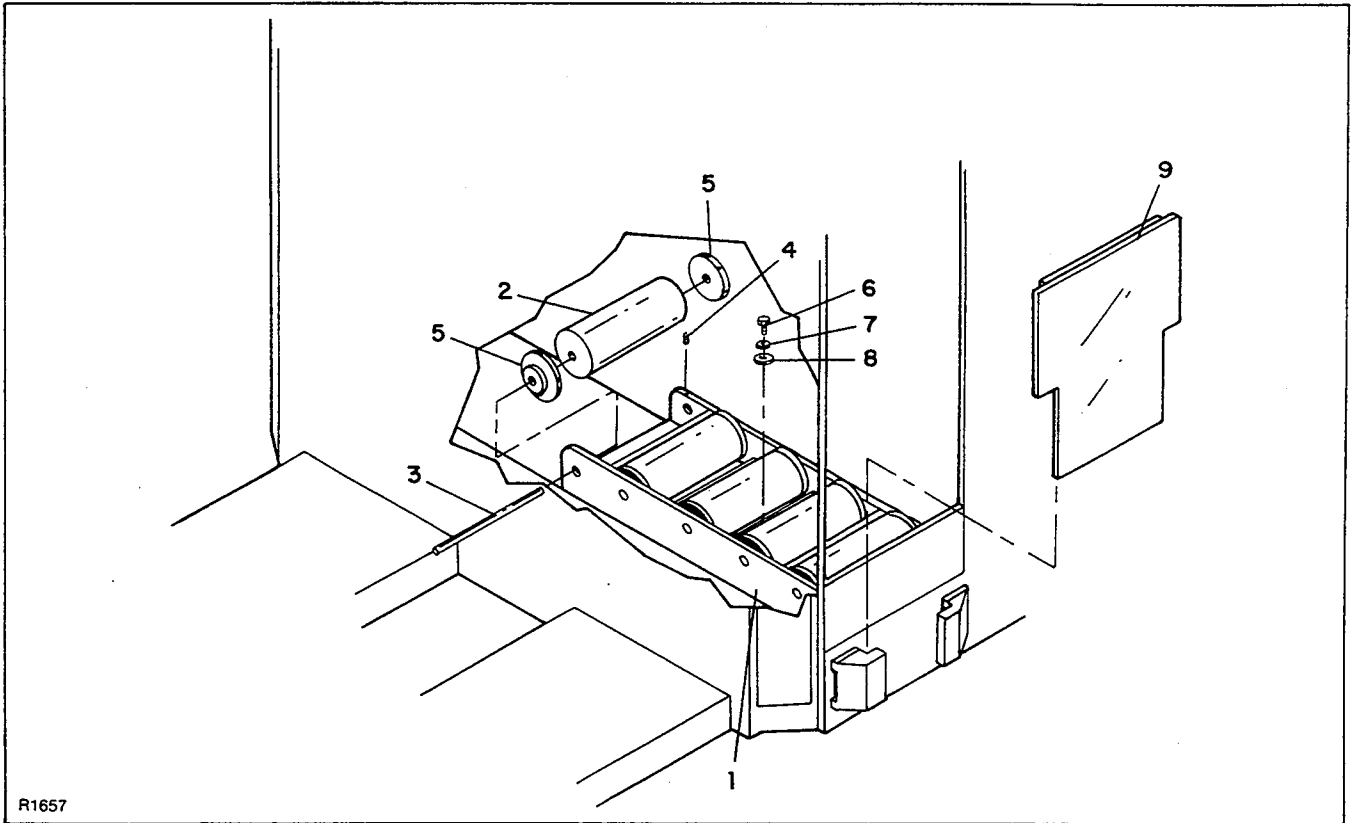

Figure 3-29. Battery Rollout Tray

INDEX NO.	PART NO.	PART NAME	NO. REQD.
1	504392-01	Tray Assembly Rollout (6.62 in. wide)	1
2	302501	Roller	5
3	270106	Rod	5
4	073465	Setscrew	5
5	051185	Bearing End Roller	10
1	504392-02	Tray Assembly Rollout (12.88 in. wide)	1
2	302507	Roller	5
3	270119	Rod	5
4	073461	Setscrew	5
5	051185	Bearing End Roller	10
6	063478	Hex Hd. Screw 1/4-20 x 3 in.	4
7	077209	Lockwasher, 1/4 in.	4
8	077031	Flat Washer, 1/4 in.	4
9	504393-01	Retainer (Battery size 6.62x31.18x23.25)	2
9	504393-02	Retainer (Battery size 13.00x31.25x23.25)	2
9	504393-03	Retainer (Battery size 6.62x25.38x31.00)	2