

6

5

4

3

2

1

ITEM	PRODUCT NAME	REV	PRODUCT DESCRIPTION	MATERIAL	PROCESS	QTY
01	TOP HOUSING	A	LID TO HOUSE COMPONENTS	PA6-GF15	INJECTION MOULDED	1
02	BASE + SEAL	A	OVERMOULD SEAL FOR IP RATING	TPE	INJECTION MOULDED	1
03	BOTTOM HOUSING	A	BASE TO HOUSE COMPONENTS	PA6-GF15	INJECTION MOULDED	1

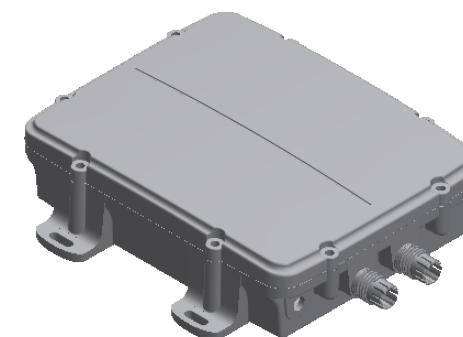
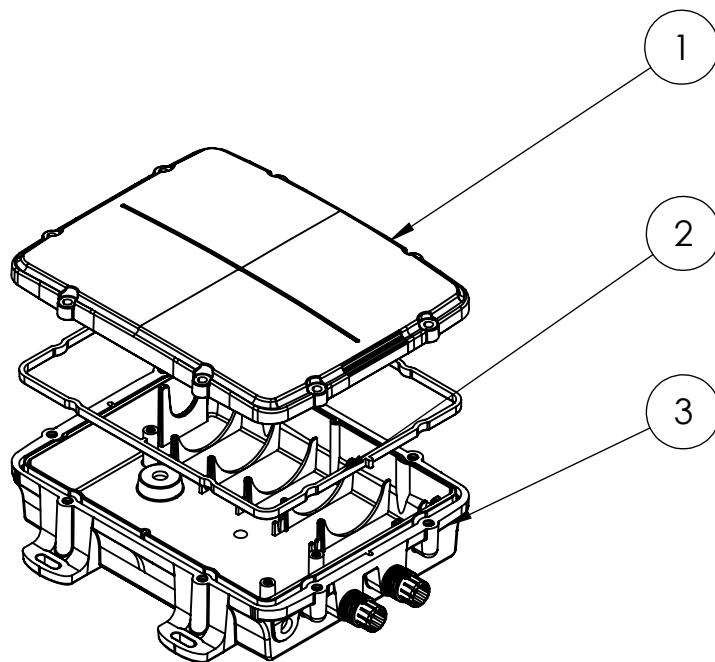

SPECIAL REQUIREMENTS		1ST ANGLE	digital matter		MATERIAL:	TITLE 240304 HAWK 2D ASSEMBLY DRW		QTY.	
UNLESS OTHERWISE SPECIFIED: DIMENSIONS ARE IN MILLIMETERS SURFACE FINISH: TOLERANCES: LINEAR: ANGULAR:			APPROVALS	NAME	DATE	CLIENT	PART NO.	PROJECT NO.	REV.
			DRAWN	K.F	04/03/2024	DME	N/A	N/A	A
			CHECKED	B.T	04/03/2024		N/A		
					A4	SCALE:1:3	DO NOT SCALE DRAWING	SHEET 1 OF 6	

D-067 TECHNICAL DRAWING TEMPLATE-19JANUARY2023-REV00

6

5

4

3

2

1

6

5

4

3



2

1

REVISIONS

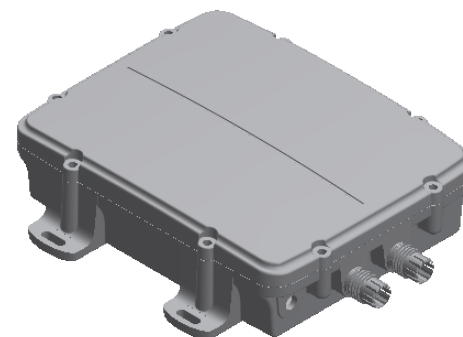
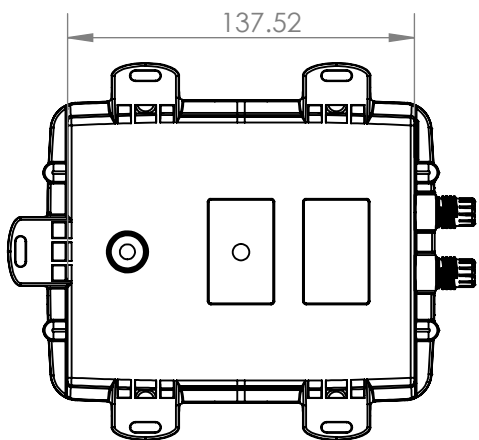
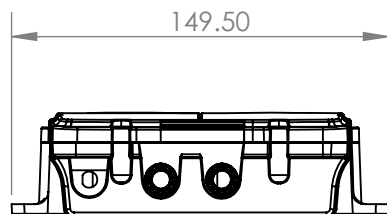
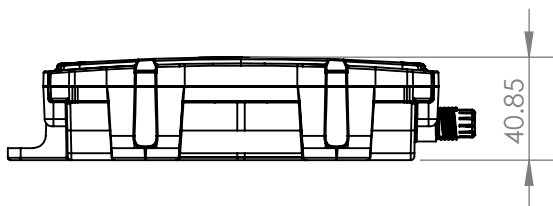
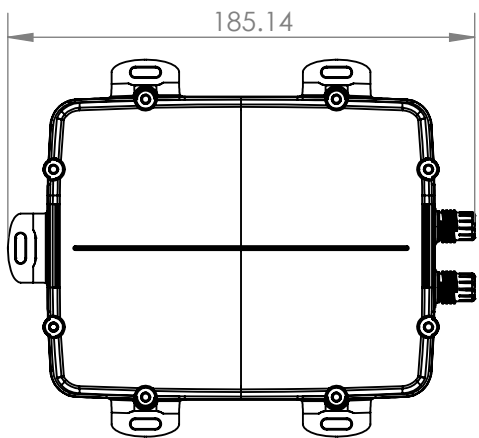
ZONE	REV	DATE	DRAWNBY	APPROVED	DESCRIPTION	PARTNO	AR
	A	05/06/2023	K.F UVT	P.S UVT	RELEASED FOR TOOLING	N/A	N/A



SPECIAL REQUIREMENTS UNLESS OTHERWISE SPECIFIED: DIMENSIONS ARE IN MILLIMETERS SURFACE FINISH: TOLERANCES: LINEAR: ANGULAR:	 	MATERIAL:	TITLE 240304 HAWK 2D ASSEMBLY DRW		QTY.	
		N/A			1	
		CLIENT	PART NO. N/A	PROJECT NO. N/A		REV. A
	APPROVALS	NAME	DATE	DME	TOOL NO. N/A	
	DRAWN	K.F	04/03/2024			
	CHECKED	B.T	04/03/2024			
				A4	SCALE:1:3	DO NOT SCALE DRAWING
						SHEET 2 OF 6

6

5

4

3

2

1

6

5

4

3

2

1

REVISIONS				
ZONE	REV.	DESCRIPTION	DATE	APPROVED
-	A	RELEASED FOR MANUFACTURING	06.05.2023	K.F UVT

D

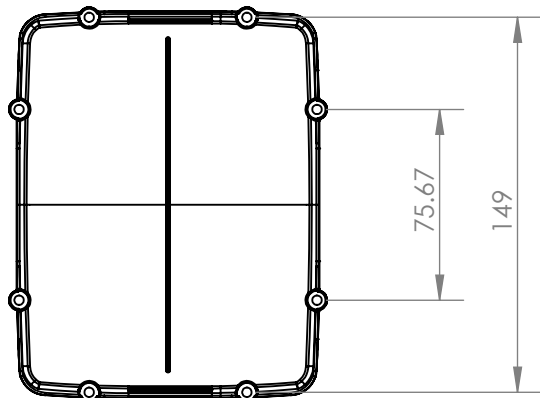

C

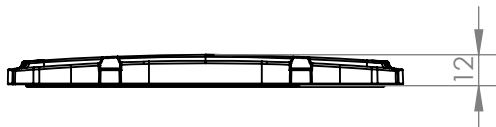

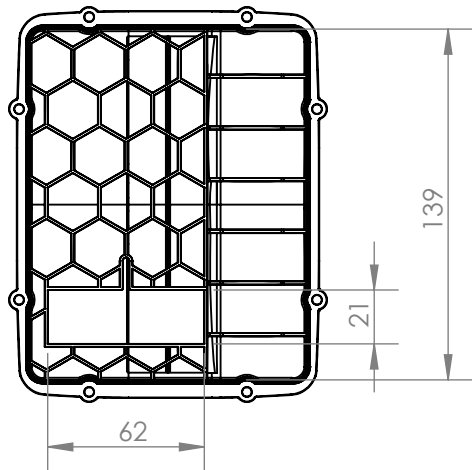

B

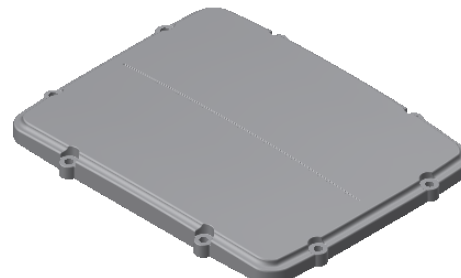

A



SPECIAL REQUIREMENTS  UNLESS OTHERWISE SPECIFIED: DIMENSIONS ARE IN MILLIMETERS SURFACE FINISH: TOLERANCES: LINEAR: ANGULAR:				MATERIAL: PA6-GF15	TITLE 240304 HAWK 2D ASSEMBLY DRW		QTY. 1
	APPROVALS	NAME	DATE	CLIENT DME	PART NO. 01	PROJECT NO. N/A	REV. A
	DRAWN	K.F	04/03/2024		TOOL NO. N/A		
CHECKED	B.T	04/03/2024	A4	SCALE:1:3	DO NOT SCALE DRAWING	SHEET 3 OF 6	

6

5

4

3

2

1

D

C

B

A

6

5

4

3



2

1

REVISIONS

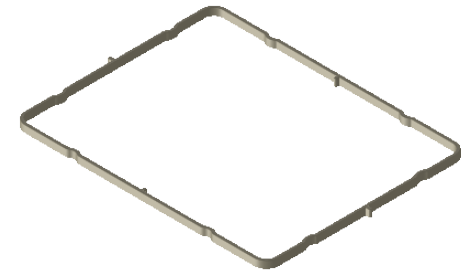
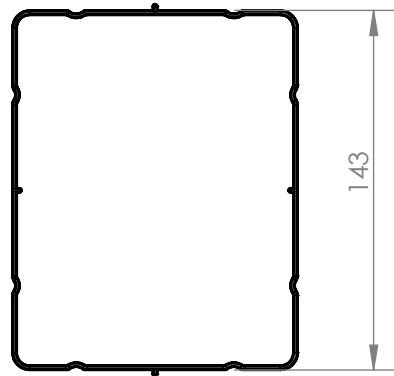
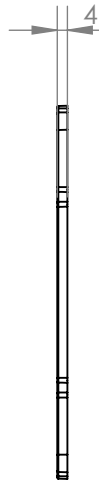
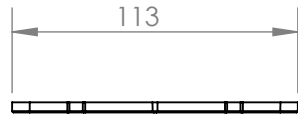
ZONE	REV.	DESCRIPTION	DATE	APPROVED
-	A	RELEASED FOR MANUFACTURING	05.06.2023	KF UVT



SPECIAL REQUIREMENTS  UNLESS OTHERWISE SPECIFIED: DIMENSIONS ARE IN MILLIMETERS SURFACE FINISH: TOLERANCES: LINEAR: ANGULAR:				MATERIAL: TPE	TITLE 240304 HAWK 2D ASSEMBLY DRW		QTY. 1
	APPROVALS	NAME	DATE	CLIENT	PART NO. 02	PROJECT NO.	REV. A
	DRAWN	K.F	04/03/2024	DME	TOOL NO. N/A	N/A	
	CHECKED	B.T	04/03/2024	A4	SCALE:1:3	DO NOT SCALE DRAWING	SHEET 4 OF 6

6

5

4

3

2

1

D

D

C

C

B

B

A

A

6

5

4

3

2

1

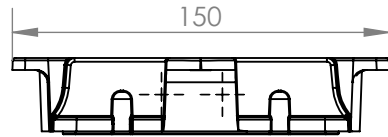

REVISIONS				
ZONE	REV.	DESCRIPTION	DATE	APPROVED
-	A	RELEASED FOR MANUFACTURING	05.06.2023	K,F UVT

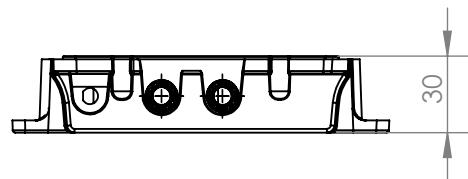
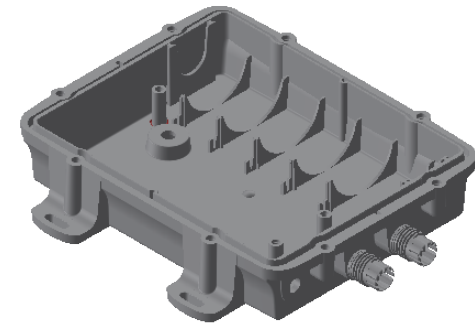
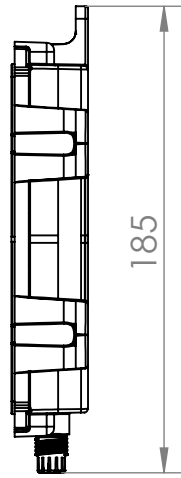
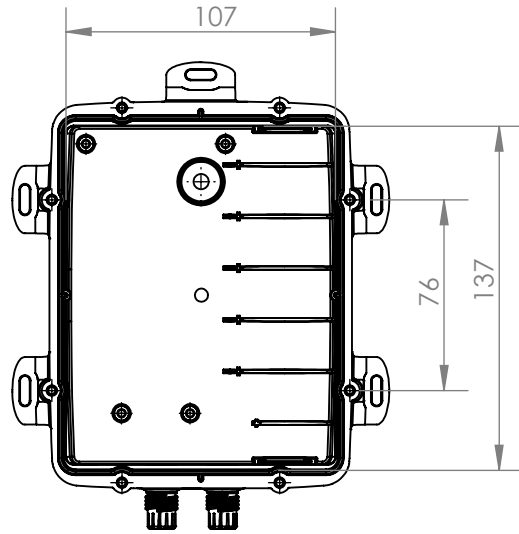

SPECIAL REQUIREMENTS		1ST ANGLE		MATERIAL: PA6-GF15		TITLE 240304 HAWK 2D ASSEMBLY DRW		QTY. 1
UNLESS OTHERWISE SPECIFIED: DIMENSIONS ARE IN MILLIMETERS SURFACE FINISH: TOLERANCES: LINEAR: ANGULAR:		APPROVALS	NAME	DATE	CLIENT	PART NO. 03	PROJECT NO.	REV. A
		DRAWN	K.F	04/03/2024	DME	N/A	N/A	
		CHECKED	B.T	04/03/2024	A4			
D-067 TECHNICAL DRAWING TEMPLATE-19JANUARY2023-REV00		SCALE:1:3		DO NOT SCALE DRAWING		SHEET 5 OF 6		

6

5

4

3

2

1

6 5 4 3 2 1

D

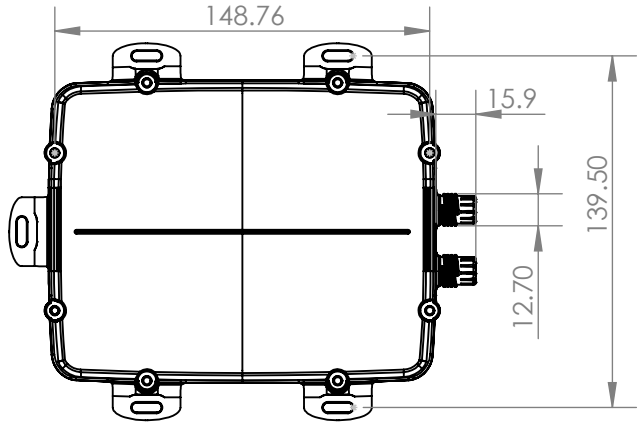

D

C

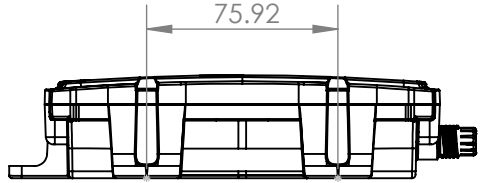

C

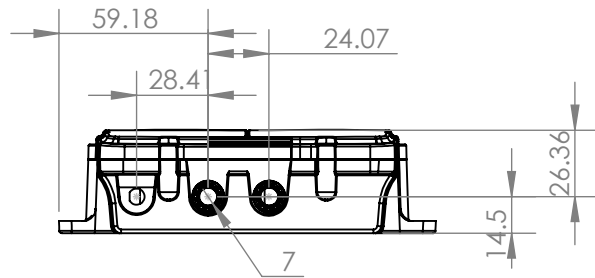

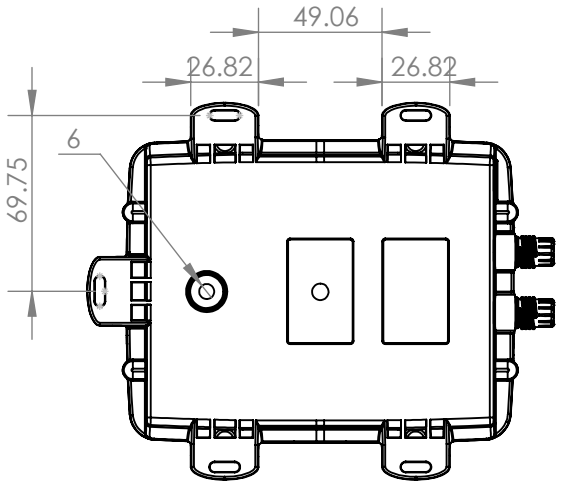

B

B



A

A

SPECIAL REQUIREMENTS  1ST ANGLE UNLESS OTHERWISE SPECIFIED: DIMENSIONS ARE IN MILLIMETERS SURFACE FINISH: TOLERANCES: LINEAR: ANGULAR:				MATERIAL: N/A	TITLE 240304 HAWK 2D ASSEMBLY DRW		QTY. 1
	APPROVALS	NAME	DATE	CLIENT	PART NO. N/A	PROJECT NO.	REV. A
	DRAWN	K.F	04/03/2024	DME	TOOL NO. N/A	N/A	
CHECKED				A4	SCALE:1:3	DO NOT SCALE DRAWING	SHEET 6 OF 6

6 5 4 3 2 1