



BOLT DOWN PEDESTAL INSTALLATION INSTRUCTIONS

12028 E. PHILADELPHIA ST. WHITTIER CALIFORNIA 90601 U.S.A. www.rasmussen.biz

ATTENTION! READ INSTRUCTIONS CAREFULLY BEFORE ASSEMBLY

WARRANTY

Rasmussen will repair or replace at our election any part that has failed due to defects in material or workmanship for a period of one year from date of purchase.

WARNING

This Bolt Down Pedestal assembly **MUST** be bolted down securely in all instances. The assembly can be secured either on a Concrete Base or a Wooden Deck Base.

PEDESTAL BASE

PARTS LIST (see drawings on next page)

Item #	DESCRIPTION	QTY
A	SIDE PANELS - 1RH & 1 LH	2
B	REAR PANEL	1
C	TOP SUPPORT PLATE	1
D	BASE COVER PANEL	1
E	REAR ACCESS PANEL	1
F	PEDESTAL SUPPORT	1
G	BOLT DOWN BASE PLATE	1
7004	PAN HEAD 1/4" X 20 1/2"	10
7012	HEX BOLTS 1/4" X 20 X 3/4"	12
7014	FLAT WASHERS	16
7011	SPRING WASHERS	12
3400	1/2" HOSE 48" LONG	1
7007	1/4" X 20 HEX NUTS	3

The installation **MUST** comply with all local codes and the gas line/connections should be carried out by an experienced Gas Installer. Read these instructions fully and identify the parts before proceeding further.

Wooden Deck Installation

1. To ensure a safe installation, the minimum deck thickness should be 1 ½" lumber.
2. Ensure the deck area is clear and level.
3. Using the BOLT DOWN BASE PLATE as a template, mark and drill 4 x ½" diam. holes through the decking.
4. Place the BOLT DOWN BASE PLATE over the hole locations ensuring the rear of the BOLT DOWN BASE PLATE is positioned correctly.
5. Bolt down the BOLT DOWN BASE PLATE using 3/8" diam. threaded rod, nuts and washers (not included) as shown in Figure 1 (below).
6. Tighten securely.

FIGURE 1

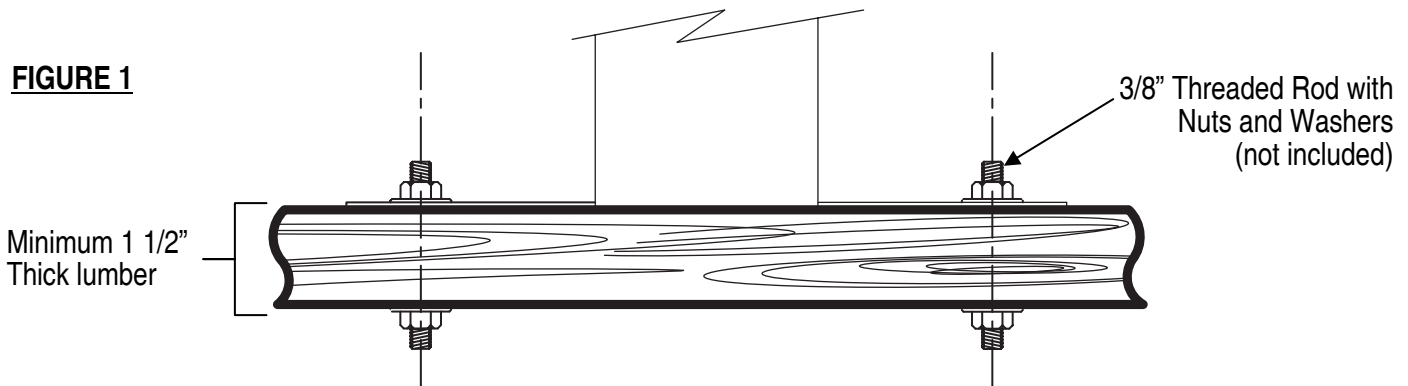

Concrete Deck Installation

1. Ensure the deck area is clear and level.
2. Using the BOLT DOWN BASE PLATE as a template, mark and drill eight 3/8" dia. x 3" deep holes into the Concrete Deck.
3. Insert eight Anchor Bolts into the pre-drilled holes in the Concrete Deck.
4. Place the BOLT DOWN BASE PLATE over the Anchor Bolts ensuring the rear of the BOLT DOWN BASE PLATE is positioned correctly.
5. Fit one flat washer, one split washer and one nut onto each Anchor Bolt and bolt down the BOLT DOWN BASE PLATE as shown in Figure 2 (below) (parts not supplied).
6. Tighten securely.

FIGURE 2

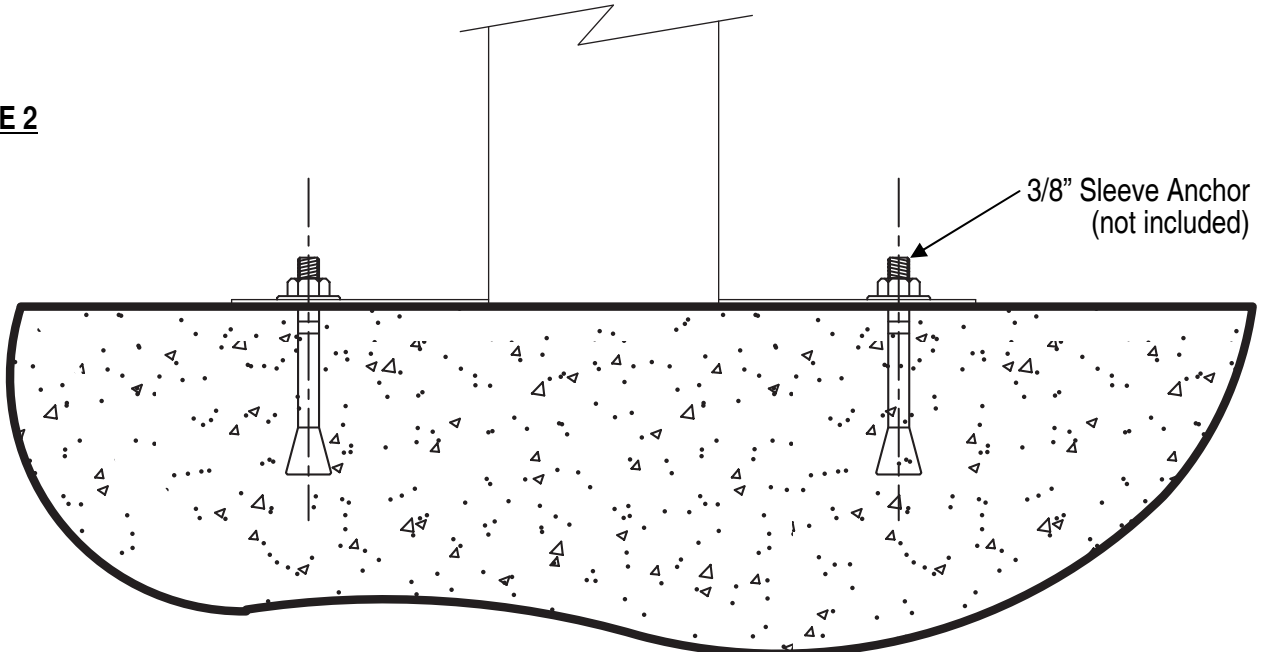

Common Installation Instructions

1. Bolt down Base Plate (Figure 3G) as detailed on previous page.
2. Place the Outer Base Cover Panel (Figure 3D) over the previously secured Base Plate.
3. Place the Top Support Plate (Figure 3C) onto the Pedestal Support (Figure 3F) (see note below) and secure with eight $\frac{1}{4}$ " x 20 bolts, eight flat washers and eight split-washers. Tighten securely.
4. Place the Right and Left Hand Side Panels (Figure 3A) into position, locating the bottom flange on top of the Top Support Plate (Figure 3C).
5. Bolt down each Side Panel onto the Top Support Plate using two $\frac{1}{4}$ " x 20 x 1" hex head bolts from below.
6. Carefully Position the BBQ over the two Side Panels and bolt down to the Drip Tray runners and the Side Panel bottom flange.
7. Install the supplied gas supply components. After making the incoming gas connection and testing the appliance for gas leaks in accordance with the instructions shown in the Care and Use manual. Fit the removable Rear Panel (Figure 3B) and the Rear Access Panel (Figure 3E) using the $\frac{1}{4}$ " x 20 x $\frac{1}{2}$ " pan head bolts, and flat washers provided.

FIGURE 3

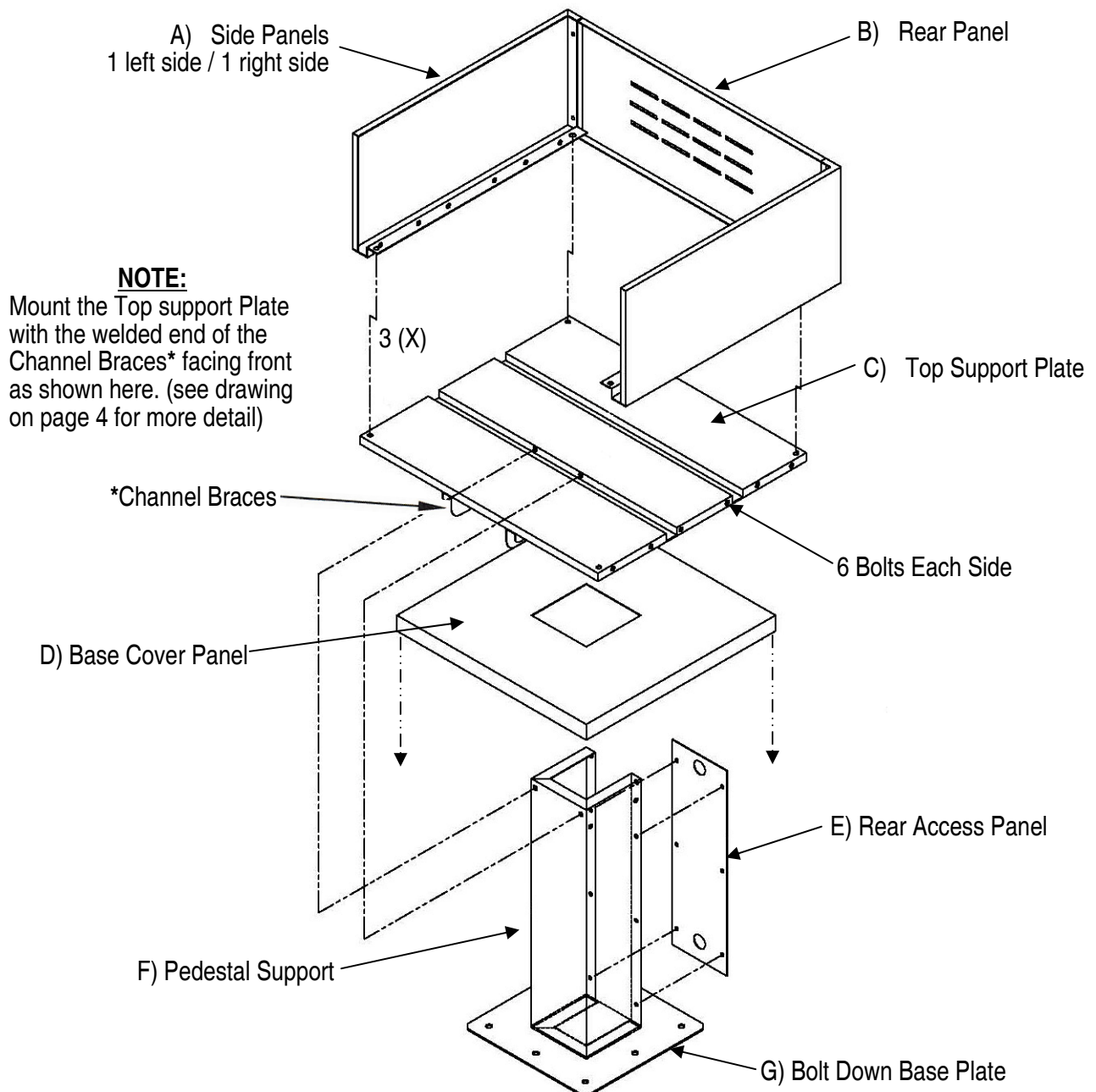

Solairé[®]

INFRARED GRILLING SYSTEMS

BOLT DOWN PEDESTAL

Front View

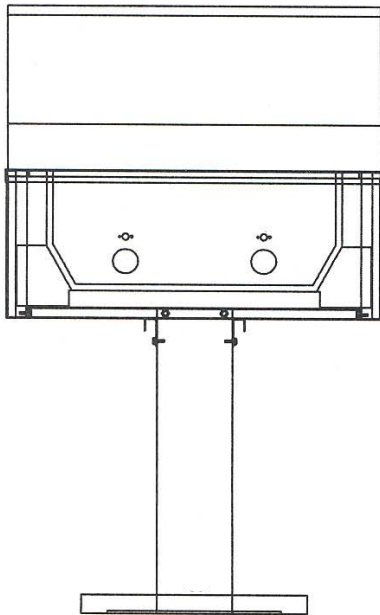

Side View

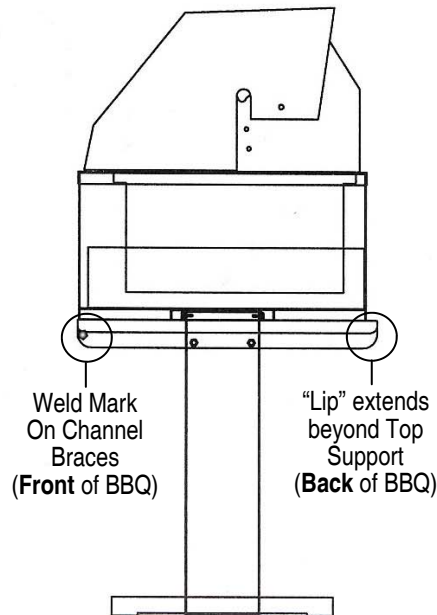

Rear View

