



Installation Manual COLOR LCD SOUNDER Model FCV-1150

SAFETY INSTRUCTIONS	i
SYSTEM CONFIGURATION	iii
EQUIPMENT LISTS.....	iv
1. MOUNTING	1
1.1 Display Unit	1
1.2 Transducer	1
1.3 Water Temperature/Speed Sensor.....	2
2. WIRING	3
2.1 Interconnection	3
2.2 Wiring Standard Equipment.....	4
2.3 Input/Output Sentences.....	6
3. INITIAL SETTING	8
3.1 Language Setting	8
3.2 Transducer Data.....	9
3.3 Speed/Water Temperature Sensor Calibration	15
3.4 NMEA Port Setting	16
3.5 Heaving Setting	18
APPENDIX1 TRANSDUCER 82B-35R	AP-1
APPENDIX2 INSTALLATION OF TEMPERATURE SENSORS.....	AP-3
PACKING LIST	A-1
OUTLINE DRAWINGS.....	D-1
INTERCONNECTION DIAGRAM	S-1





SAFETY INSTRUCTIONS

The operator and installer must read the applicable safety instructions before attempting to install or operate the equipment.

 WARNING	Indicates a potentially hazardous situation which, if not avoided, could result in death or serious injury.
 CAUTION	Indicates a potentially hazardous situation which, if not avoided, can result in minor or moderate injury.

	Warning, Caution		Prohibitive Action		Mandatory Action
---	------------------	---	--------------------	---	------------------

 WARNING	
	ELECTRICAL SHOCK HAZARD Do not open the equipment unless totally familiar with electrical circuits and service manual.
Only qualified personnel should work inside the equipment.	
Turn off the power at the switchboard before beginning the installation. Connect to a dedicated breaker in the power distributor.	
Fire or electrical shock can result if the power is left on.	
Do not install the equipment where it may get wet from rain or water splash.	
Water in the equipment can result in fire, electrical shock or damage the equipment.	
Be sure no water leaks in at the transducer mounting location.	
Water leakage can sink the vessel. Also, confirm that the transducer will not loosen by ship's vibration. The installer of the equipment is solely responsible for the proper installation of the equipment. FURUNO will assume no responsibility for any damage associated with improper installation.	

 WARNING	
Be sure that the power supply is compatible with the voltage rating of the equipment.	
Connection of an incorrect power supply can cause fire or damage the equipment. The voltage rating of the equipment appears on the label above the power connector.	
Install the transducer according to the installation instructions.	
Failure to install the transducer correctly may result in water leakage and damage to the ship's hull.	
For wooden or FRP vessel using a steel tank, attach a zinc plate to the hull to prevent electrolytic corrosion.	
Electrolytic corrosion can, in the worst case, result in loss of the transducer.	

 **CAUTION**



Ground the equipment to prevent mutual interference.

Observe the following compass safe distances to prevent interference to a magnetic compass:

	Standard compass	Steering compass
CV-1150	0.75 m	0.50 m

Do not allow warm water or any other liquid other than seawater or freshwater to contact the transducer.

The transducer may become damaged.

Do not turn on the power when the transducer is in air.

The transducer may become damaged.

Do not install the transducer where noise or air bubbles is present.

Performance will be affected.

 **CAUTION**

The transducer cable must be handled carefully, following the guidelines below.

- **Keep fuels and oils away from the cable.**
- **Locate the cable where it will not be damaged.**
- **The cable sheath is made of chlorophrene or polychloride vinyl, which are easily damaged by plastic solvents such as toluene. Locate the cable well away from plastic solvents.**

SYSTEM CONFIGURATION

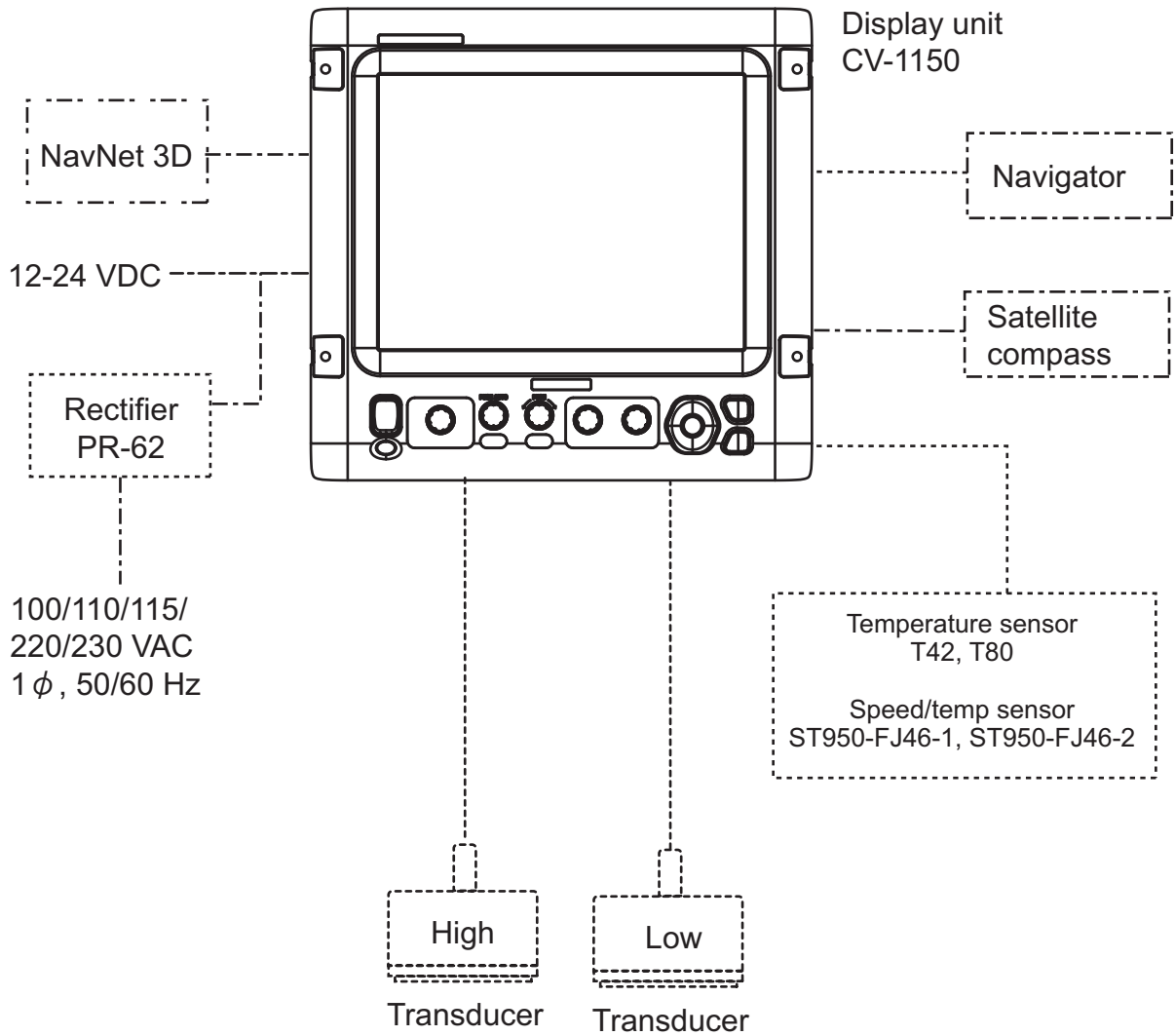

- : Standard supply
- : Optional supply
- - - - - : Local supply, External device

EQUIPMENT LISTS

Standard supply

Name	Type	Code No.	Qty	Remarks
Display Unit	CV-1150	-	1	
Spare Parts	SP02-05401	001-032-550	1 set	See back of this manual.
Accessories	FP02-05700	000-011-976	1 set	
Installation Materials	CP02-08301	001-032-560	1 set	

Option

Name	Type	Code No.	Remarks
Transducer	See next pages.	-	
Thru-hull pipe		-	
Tank		-	
Cable	MJ-A6SPF0003-050C	000-154-054-10	one end 6 pin, 5 m, for navigator
	COSPEVV/SBC 2PX0.2LF	000-111-680-10	5 m
		000-120-792-10	10 m
		000-120-793-10	15 m
LAN cable	MOD-Z072-020+	001-167-880-10	LAN cable, 2 m
	MOD-Z072-050+	001-167-890-10	LAN cable, 5 m
	MOD-Z072-100+	001-167-900-10	LAN cable, 10 m
Water temperature sensor	T-04MSB	000-026-893	Thru-hull type
	T-04MTB	000-026-894	transom type
Speed/Temperature sensor	ST950-FJ46-1	000-200-363-10	Thru-hull type
	ST950-FJ46-2	000-200-364-10	Thru-hull type
Rectifier	PR-62	000-013-484	100 V AC
		000-013-485	110 V AC
		000-013-486	220 V AC
		000-013-487	230 V AC

Combination of transducer, thru-hull pipe and tank

The contents in the table below are for your information only. Some tanks are not RoHS compliant.

Output (W)	Frequency (kHz)	Ship type	Transducer	Thru-hull pipe	Tank	
1k/1k	28/50	Steel	28F-8	TWB-6000(2)	T-656	
		FRP	50B-9B	-	-	
	28/88	Steel	28F-8	TWB-6000(2)	T-657	
		FRP	88B-8	-	-	
	50/88	Steel	50B-9B	TWB-6000(2)	T-658	
		FRP	88B-8	-	-	
	50/200	Steel	50/200-1T	TFB-5000(1)	T-603	
		FRP		TRB-1000(1) or TRB-1200	T-603-F	
1k/2k	28/200	Steel	28F-8	TWB-6000(2)	T-657	
		FRP	200B-8/8B	-	-	
	50/200	Steel	50B-9B	TWB-6000(2)	T-658	
		FRP	200B-8/8B	-	-	
	88/200	Steel	88B-8	TWB-6000(2)	T-659	
		FRP	200B-8/8B	-	-	
2k/2k	28/200	Steel	28BL-6HR 200B-8/8B	TFB-7000(2) or TWB-6000(2)	T-693	
		FRP		TRB-1100(2) or TWB-6000(2)	T-693-F	
	38/200	Steel	38BL-9HR 200B-8/8B	TFB-7000(2) or TWB-6000(2)	T-693	
		FRP		TRB-1100(2) or TWB-6000(2)	T-693-F	
	50/200	Steel	50BL-12HR 200B-8/8B	TFB-7000(2) or TWB-6000(2)	T-693	
		FRP		TRB-1100(2) or TWB-6000(2)	T-693-F	
	82/200	Steel	82B-35R 200B-8/8B	TFB-7000(2) or TWB-6000(2)	T-649	
		FRP		TRB-1100(2)	T-649-F	
	88/200	Steel	88B-10 200B-8/8B	TFB-7000(2) or TWB-6000(2)	T-649	
		FRP		TRB-1100(2)	T-649-F	
	3k/2k	68/200	Steel	68F-30H 200B-8/8B	TFB-7000(2) or TWB-6000(2)	T-647
			FRP		TRB-1100(2)	T-647-F
107/200		Steel	100B-10R 200B-8/8B	TFB-7000(2) or TWB-6000(2)	T-649	
		FRP		TRB-1100(2)	T-649-F	

Output (W)	Frequency (kHz)	Ship type	Transducer	Thru-hull pipe	Tank
3k/3k	28/38	Steel	28BL-12HR 38BL-15HR	TFB-7000(2) or TWB-6000(2)	T-681
		FRP		TRB-1100(2)	T-681-F
	28/50	Steel	28BL-12HR 50BL-24HR	TFB-7000(2) or TWB-6000(2)	T-681
		FRP		TRB-1100(2)	T-681-F
	28/88	Steel	28BL-12HR 88F-126H	TFB-7000(2) or TWB-6000(2)	T-682
		FRP		TRB-1100(2)	T-682-F
	28/150	Steel	28BL-12HR 150B-12H	TFB-7000(2) or TWB-6000(2)	T-683
		FRP		TRB-1100(2)	T-683-F
	28/200	Steel	28BL-12HR 200B-12H	TFB-7000(2) or TWB-6000(2)	T-683
		FRP		TRB-1100(2)	T-683-F
	38/50	Steel	38BL-15HR 50BL-24HR	TFB-7000(2) or TWB-6000(2)	T-681
		FRP		TRB-1100(2)	T-681-F
	38/88	Steel	38BL-15HR 88F-126H	TFB-7000(2) or TWB-6000(2)	T-682
		FRP		TRB-1100(2)	T-682-F
	38/150	Steel	38BL-15HR 150B-12H	TFB-7000(2) or TWB-6000(2)	T-683
		FRP		TRB-1100(2)	T-683-F
	38/200	Steel	38BL-15HR 200B-12H	TFB-7000(2) or TWB-6000(2)	T-683
		FRP		TRB-1100(2)	T-683-F
	50/88	Steel	50BL-24HR 88F-126H	TFB-7000(2) or TWB-6000(2)	T-682
		FRP		TRB-1100(2)	T-682-F
50/150	Steel	50BL-24HR 150B-12H	TFB-7000(2) or TWB-6000(2)	T-683	
	FRP		TRB-1100(2)	T-683-F	
50/200	Steel	50BL-24HR 200B-12H	TFB-7000(2) or TWB-6000(2)	T-683	
	FRP		TRB-1100(2)	T-683-F	
68/150	Steel	68F-30H 150B-12H	TFB-7000(2) or TWB-6000(2)	T-646	
	FRP		TRB-1100(2)	T-646-F	
68/200	Steel	68F-30H 200B-12H	TFB-7000(2) or TWB-6000(2)	T-646	
	FRP		TRB-1100(2)	T-646-F	

Output (W)	Frequency (kHz)	Ship type	Transducer	Thru-hull pipe	Tank	
3k/3k	88/150	Steel	88F-126H 150B-12H	TFB-7000(2) or TWB-6000(2)	T-685	
		FRP		TRB-1100(2)	T-685-F	
	88/200	Steel	88F-126H 200B-12H	TFB-7000(2) or TWB-6000(2)	T-685	
		FRP		TRB-1100(2)	T-685-F	
1k	28	Steel	28F-8	TFB-5000(1)	T-604	
		FRP		TRB-1000(1) or TRB-1200	T-604-F	
	50	Steel	50B-6/6B	TFB-5000(1)	T-605	
		FRP		TRB-1000(1)	T-605-F	
		Steel	50B-9B	TFB-5000(1)	T-603	
		FRP		TRB-1000(1) or TRB-120	T-603-F	
	68	Steel	68F-8H	TFB-5000(1)	T-621	
		FRP		TRB-1000(1) or TRB-120	T-621-F	
	88	Steel	88B-8	TFB-5000(1)	T-606	
		FRP		TRB-1000(1) or TRB-120	T-606-F	
	200	Steel	200B-5S	TFB-5000(1)	T-605	
		FRP		TRB-1000(1)	T-605-F	
	2k	28	Steel	28BL-6HR	TFB-5000(1)	T-702
			FRP		TRB-1000(1)	T-702-F
38		Steel	38BL-9HR	TFB-5000(1)	T-702	
		FRP		TRB-1000(1)	T-702-F	
50		Steel	50BL-12HR	TFB-5000(1)	T-702	
		FRP		TRB-1000(1)	T-702-F	
82		Steel	82B-35R	TFB-5000(1)	T-609	
		FRP		TRB-1000(1) or TRB-120	T-609-F	
88		Steel	88B-10	TFB-5000(1)	T-609	
		FRP		TRB-1000(1) or TRB-120	T-609-F	
200		Steel	200B-8/8B	TFB-5000(1)	T-608	
		FRP		TRB-1000(1) or TRB-120	T-608-F	

Output (W)	Frequency (kHz)	Ship type	Transducer	Thru-hull pipe	Tank
3k	28	Steel	28BL-12HR	TFB-4000(1)	T-616
		FRP		TRB-1000(1)	T-616-F
	38	Steel	38BL-15HR	TFB-4000(1)	T-616
		FRP		TRB-1000(1)	T-616-F
	50	Steel	50BL-24HR	TFB-4000(1)	T-616
		FRP		TRB-1000(1)	T-616-F
	68	Steel	68F-30H	TFB-5000(1)	T-614
		FRP		TRB-1000(1)	T-614-F
	88	Steel	88F-126H	TFB-4000(1)	T-618
		FRP		TRB-1000(1)	T-618-F
	107	Steel	100B-10R	TFB-5000(1)	T-609
		FRP		TRB-1000(1) or TRB-120	T-609-F
	150	Steel	150B-12H	TFB-5000(1)	T-615
		FRP		TRB-1000(1)	T-615-F
	200	Steel	200B-12H	TFB-5000(1)	T-615
		FRP		TRB-1000(1)	T-615-F

1. MOUNTING

NOTICE

Do not apply paint, anti-corrosive sealant or contact spray to coating or plastic parts of the equipment.

Those items contain organic solvents that can damage coating and plastic parts, especially plastic connectors.

1.1 Display Unit



WARNING

Turn off the power at the switchboard before beginning the installation.

Fire or electrical shock can result if the power is left on.

Mounting considerations

- Locate the unit out of direct sunlight.
- The operator should face the bow while viewing the display screen.
- Select a location where the display screen can be easily observed while operating the control panel.
- Leave sufficient space around the unit for maintenance and servicing. Recommended maintenance space appears in the outline drawing at the back of this manual.
- Observe the compass safe distances on page ii to prevent deviation of a magnetic compass.

The display unit can be mounted on the tabletop or on the panel (flush mounting). Mount the unit, referring to the outline drawing at the back of this manual.

1.2 Transducer

The performance of the echo sounder depends upon the transducer position. A place least affected by air bubbles should be selected since turbulence blocks the sounding path. Further, select a place least influenced by engine noise. It is known that air bubbles are fewest at the place where the bow first falls and the next wave rises, at usual cruising speed.

Note: The face of the transducer must be facing the sea bottom in normal cruising trim of the boat.

2. WIRING

2.1 Interconnection

Refer to the interconnection diagram at the back of this manual for detailed information.

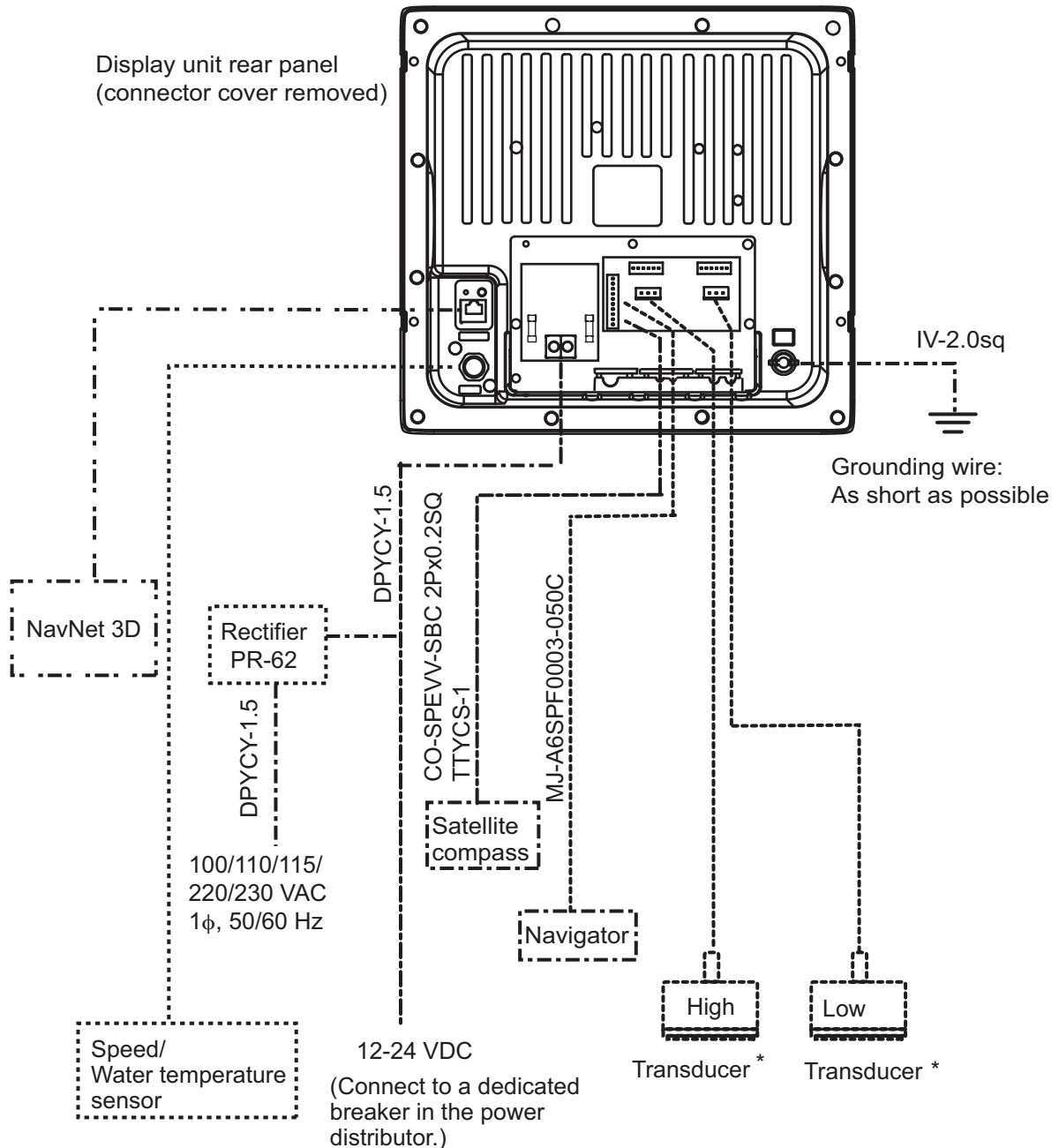

*: This unit cannot accept transducers of 53 to 65 kHz, 111 to 139 kHz and 171 to 183 kHz.

Wiring diagram for FCV-1150

2.2 Wiring Standard Equipment

Power cable

This video sounder is designed to be powered with 12-24 VDC power. Use the cable DPYCY-1.5 (Japan Industry Standard) or equivalent.

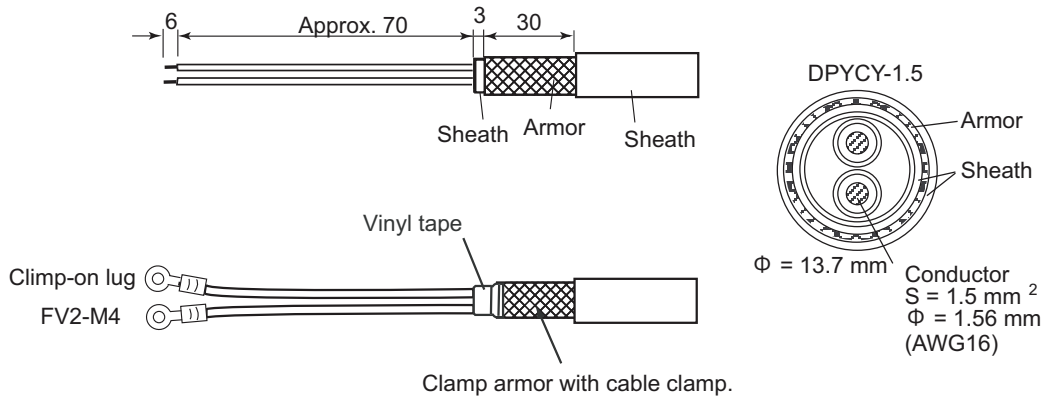

Power cable DPYCY-1.5 (JIS cable)

Transducer

Separate the transducer cable well away from power cables to prevent interference. Connect the cable to the transducer port (for high frequency and/or low frequency) at the rear of the display unit. Fabricate the cable as below.

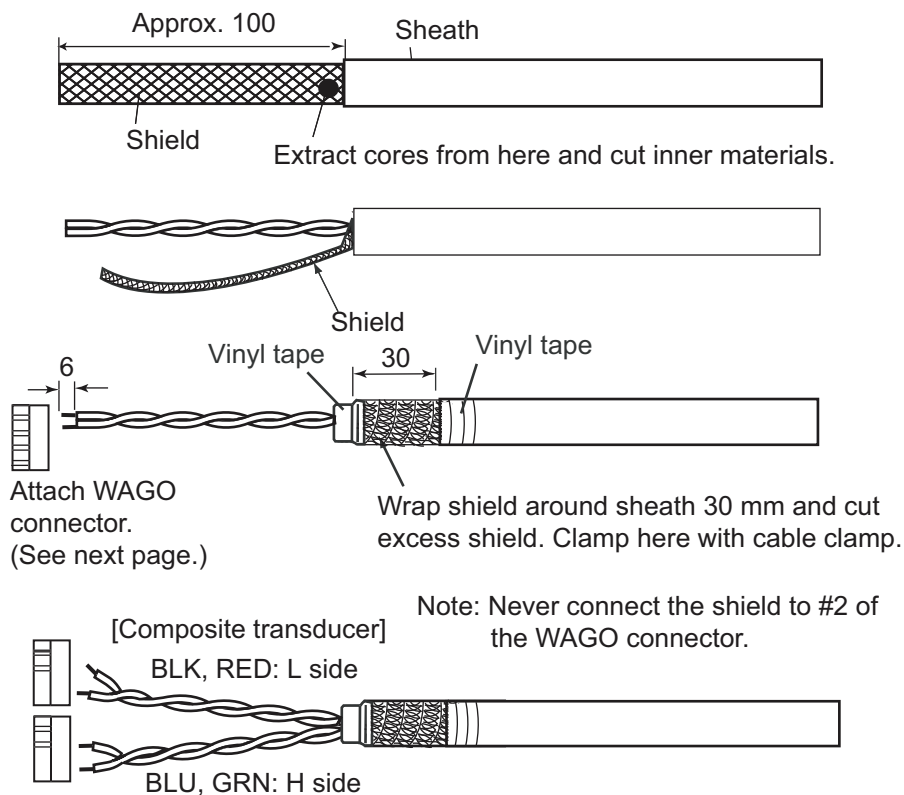

Fabrication of transducer cable

Note: FCV-1150 cannot accept the transducers of 53 - 65 kHz, 111 to 139 kHz and 171 - 183 kHz.

NMEA port

Connect a GPS navigator, etc. to NMEA port J2 #1 to #4. You can connect two sensors (for example, GPS receiver GP-310B and smart sensor). One connects to NMEA port J2 #1 to #2 and the other connects to the NMEA port J2 #3 to #4. A satellite compass can be connected to NMEA port J2 #5 to #6.

Cable connected to NMEA port: Furuno cable MJ series

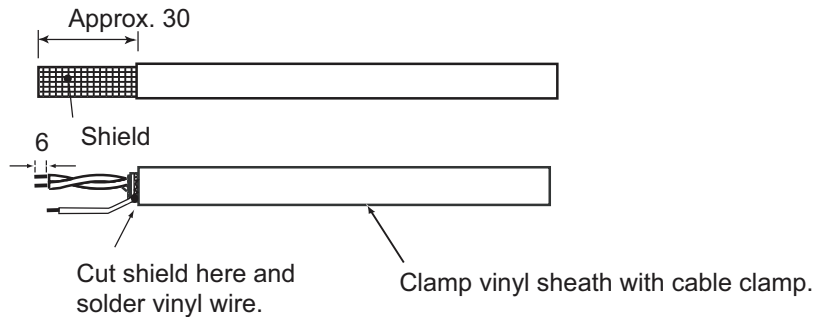

Cable connected to NMEA port: Furuno cable CO-SPEVV-SB-C

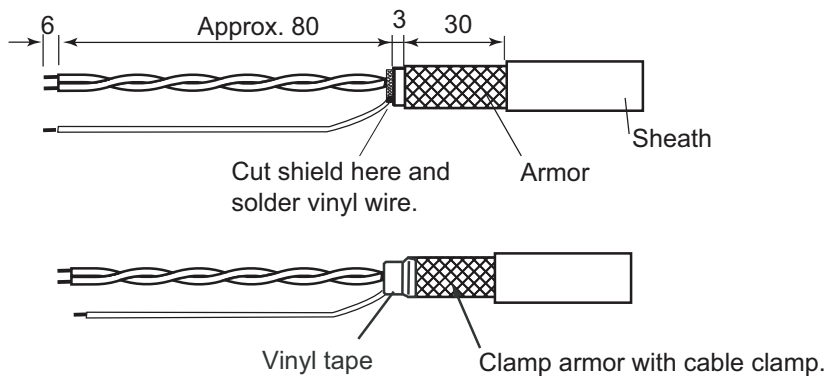

Cable connected to NMEA port: JIS cable TTYCS-1Q

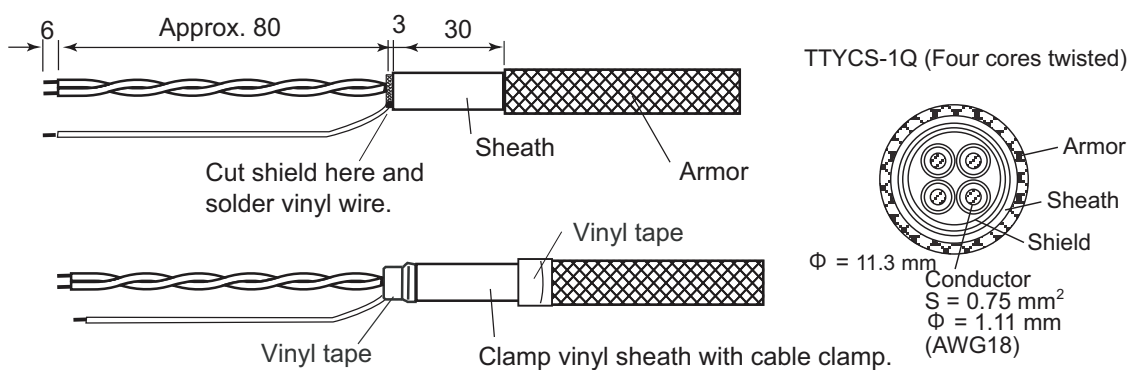

WAGO connector (for transducer and NMEA port)

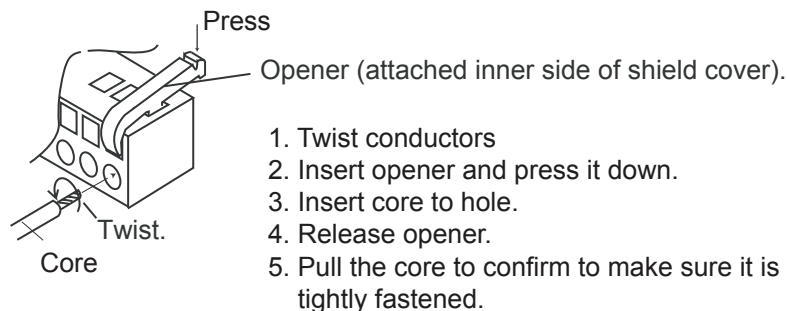

2.3 Input/Output Sentences

Input sentences

Sentence	Data	Remarks
BWC	Range/bearing to waypoint	
GGA	Time, position	GPS position
GLC	GRI, Time difference	Loran C
GLL	Latitude and longitude	GPS position
GNS	GNSS position fixing	
GTD	Time difference	Loran C
HDG	Ship's heading, deviation, variation	
HDT	True heading	
MDA	Weather information	
MTW	Water temperature	
MWV	Wind direction, wind speed (true or apparent)	
RMA	Latitude and longitude, TD, ground speed and course	Loran C
RMB	Recommended minimum navigation information	
RMC	Latitude and longitude, speed over ground and course over ground	GPS
VHW	True/magnetic bearing, speed through water	
VTG	Speed over ground and course over ground	
XTE	Cross track error	
att	Roll, pitch	
hve	Heaving data	
req	Output request for specified attribute	

Output sentences

Sentence	Data	Remarks
DBT	Depth below transducer	Ver. 1.5
DPT	Depth below transducer and offset	Ver. 2.0
MTW	Water temperature	With connection of water temperature sensor
TLL	Marker line position	Ver. 2.0
SDmrk	Mark position (L&L) and its additional data	
VHW	Speed thru water	
RMB	Navigation information	
dat	Data of specified attribute (device name)	
DBS	Depth below sea surface	

3. INITIAL SETTING

This chapter provides the information necessary for initial setup of the equipment. First turn on the power and set display language. Then, set transducer used, by model number (FURUNO transducer only) or by specifications.

3.1 Language Setting

1. Press [⏻ /BRILL] key to turn on the power. The following display appears.

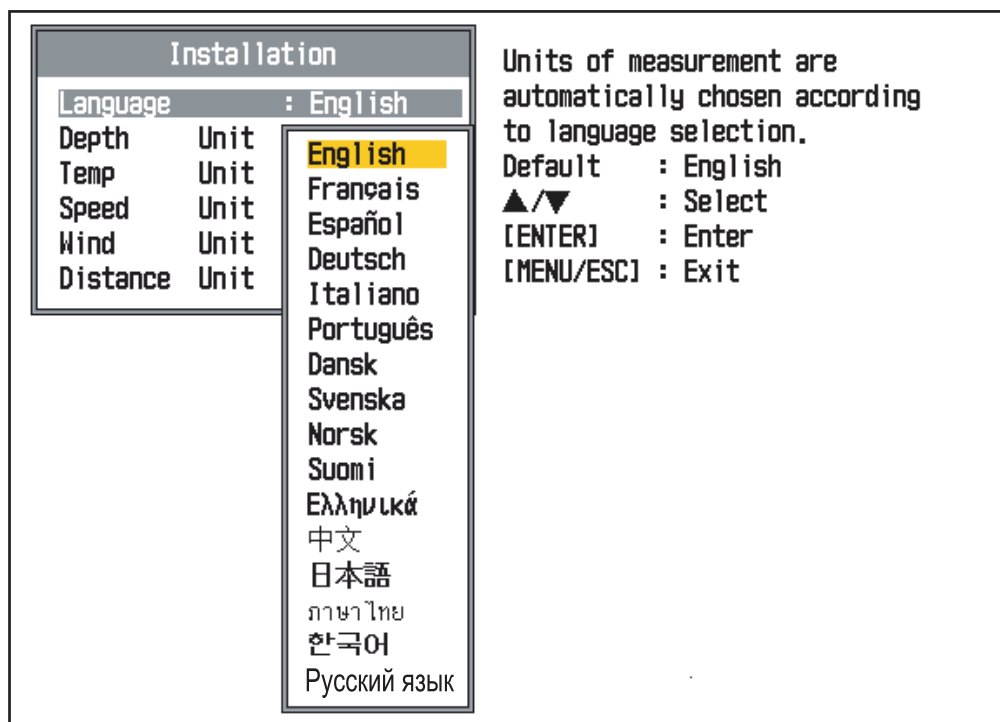

Language setting screen

2. Press ▼ or ▲ to select English as an example, and then press the **ENTER** key to set. The unit setting screen appears.

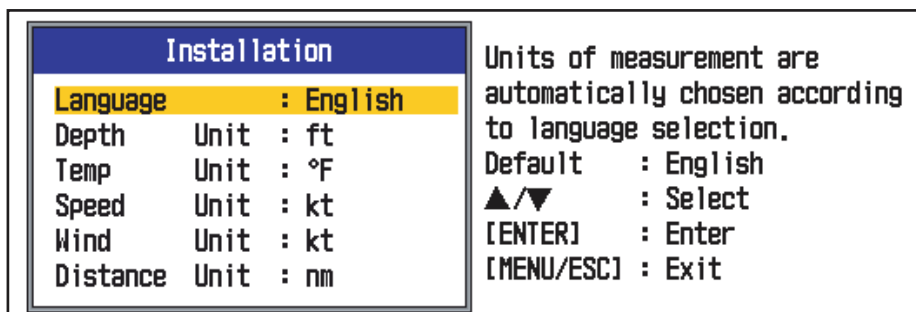

Unit setting screen

3. Set the units of measurement if necessary. For example, to set the distance unit, press ▼ to select "Distance Unit" and press the **ENTER** key. The list of selectable distance units is displayed.

4. Press ▼ or ▲ to select necessary unit and then press the **ENTER** key to set.

- Depth: m, ft, fa, pb, HR (Japanese unit)
- Temp: °C, °F
- Speed: kt, km/h, mph
- Wind: kt, km/h, mph, m/h
- Distance: nm, km, sm

5. Press the **MENU** key. The following message appears.

The transducer setting is not appropriate.
Please set the transducer appropriately.

6. Press any key. The transducer setting screen appears. Proceed to next section.

3.2 Transducer Data

 **CAUTION**

Set the transducer model number properly.

Wrong transducer setting can damage the transducer and void the warranty.

3.2.1 How to enter transducer data by transducer model

The following table shows the transducers programmed in the FCV-1150.

Type	Output (kW)	Tap	Type	Output (kW)	Tap
28F-8* ¹	1	B	50BL-24HR* ¹	3	D
28BL-6HR* ¹	2	A	50F-24H	3	B
28F-18	2	B	68F-8H* ¹	1	A
28BL-12HR* ¹	3	A	68F-30H* ¹	3	B
28F-24H	3	D	82B-35R* ¹	2	E
38BL-9HR* ¹	2	B	88B-8* ¹	1	D
38BL-15HR* ¹	3	D	88B-10* ¹	2	C
50B-6B* ¹	1	A	88F-126H* ¹	3	E
50/200-1T* ² (50 kHz)	1	B	100B-10R* ¹	3	E
50/200-1ST (50 kHz)	1	B	150B-12H* ¹	3	C
50B-9B* ¹	1	A	200B-5S* ¹	1	D
50B-12	2	A	50/200-1T* ² (200 kHz)	1	C
50BL-12	2	A	50/200-1ST (200 kHz)	1	A
50BL-12HR* ¹	2	B	200B-8B* ¹	2	C
50BL-24H	3	D	200B-12H* ¹	3	C

*¹: Available as an optional extra

*²: Compatible with ACCU-FISH™ (available as an optional extra)

Note: The “XDCR Setting” dialog box (see the illustration that follows step 1 below) only appears when turning on the power after installation, after setting the desired language and the units of measurement (see section 3.1). To open the “XDCR Setting” dialog box after completion of the transducer setting, turn off the power, then turn on the power while pressing any key. Release the key after the "XDCR Setting" dialog box appears.

1. At the transducer setting screen, confirm that "XDCR Select" is set to "XDCR Type" (default setting).

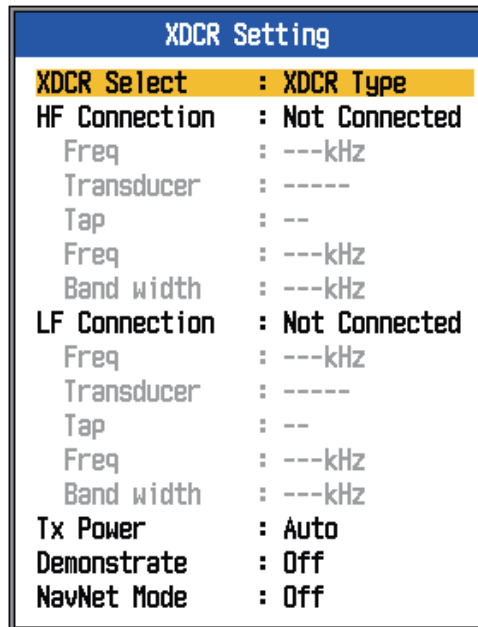

Select how to set XDCR type

Default : XDCR Type
 ▲/▼ : Select
 [ENTER] : Enter
 [POWER/BRILL]: Exit

Transducer setting screen

2. If a high frequency transducer is fitted, press ▼ to select “HF Connection” and then press the **ENTER** key.

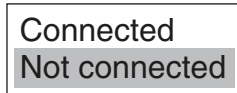

3. Press ▲ to select “Connected” and then press the **ENTER** key.
4. Press ▼ to select “Freq” and then press the **ENTER** key.

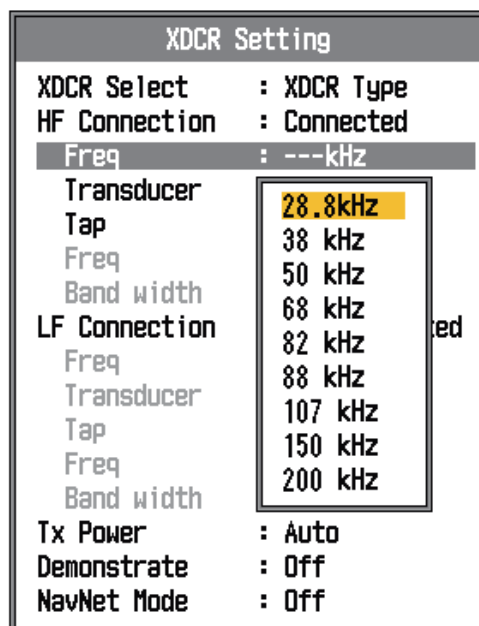

Specify the freq of XDCR installed as high freq.

Default : ---kHz
 ▲/▼ : Select
 [ENTER] : Enter
 [POWER/BRILL]: Exit

5. Press ▼ or ▲ to select the transducer frequency and then press the **ENTER** key.
6. Press ▲ to select “Transducer” and then press the **ENTER** key. The list of programmed transducers appears.

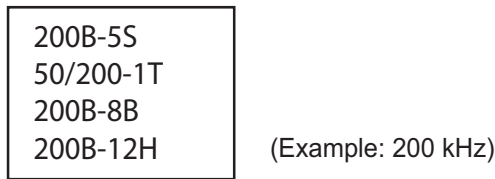

7. Press ▼ to select transducer connected and then press the **ENTER** key.
8. Jot down the alphabet which appears on the “TAP” line. You may need to change the tap setting at the rear of the display unit depending on the transducer type which is connected. For details, see below.
9. If a low frequency transducer is fitted, repeat steps 2 to 8.

Note: Leave the “Tx Power” setting at “Auto”.

10. To connect to the NavNet 3D system, press ▼ to select “NavNet Mode” and then press the **ENTER** key. Select “On” and press the **ENTER** key.

The following program versions can be connected to the FCV-1150.

MFD8/12: 1950055-02.01 and later

MFDBB: 1950064-02.01 and later

11. Press and hold down the [⏻ /BRILL] key to turn off the power.

Tap setting

You may need to change the tap setting at the rear of the display unit depending on the transducer type connected. Set the tap according to the alphabet shown when you selected transducer type.

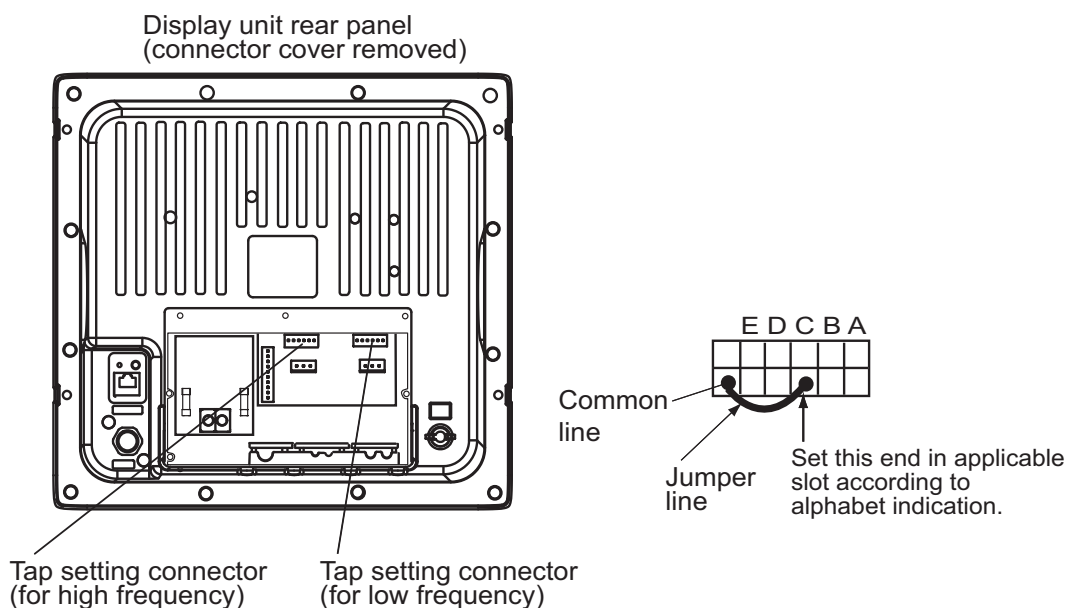
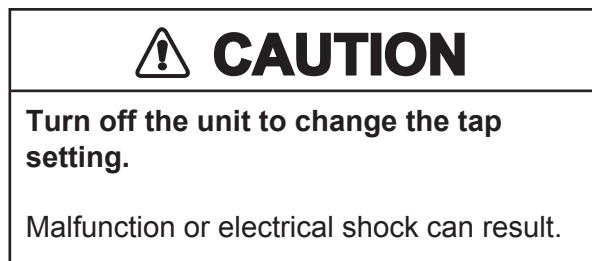

3.2.2 How to enter transducer data by transducer specifications (manual setting)

To connect the transducers which are not programmed, do as follows:

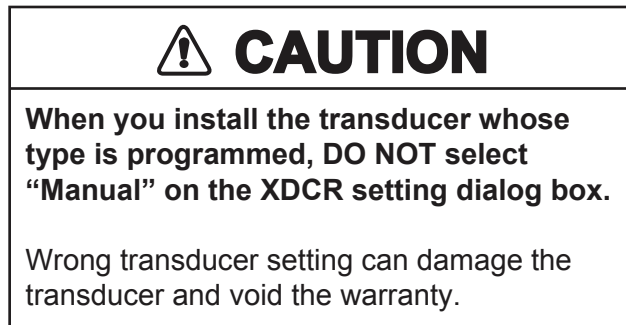

Note: The transducers of 53 - 65 kHz, 111 to 139 kHz and 171 - 183 kHz cannot be connected to the FCV-1150 because of noise.

1. At the XDCR Setting dialog box, select "XDCR Select" and press the **ENTER** key.

The following screen appears.



2. Press ▼ to select "Manual", and then press the **ENTER** key.
3. If a high frequency transducer is fitted, press ▼ to select "HF Connection" and then press the **ENTER** key.

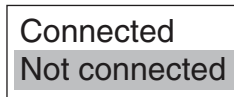

4. Press ▲ to select "Connected" and then press the **ENTER** key.
5. Press ▼ to select "Freq" and then press the **ENTER** key.

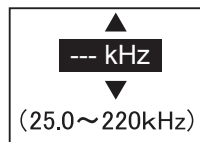

6. Press ▼ or ▲ to set the value for the frequency which is connected and then press the **ENTER** key.
7. Press ▼ to select "Band width" and then press the **ENTER** key.
8. Press ▼ or ▲ to set the value for the band width and then press the **ENTER** key. If the band width is not entered manually, it is automatically set to 1/10 of the transducer frequency.
9. If a low frequency transducer is fitted, repeat steps 3 to 8.

Note: Leave the "Tx Power" at "Auto".

10. Press and hold down the [⏻/BRILL] key to turn off the power.

Tap setting for manual setting

When you install the transducers whose type is not programmed, confirm the bottom echo to select the optimum tap setting. The output power of the tap setting; $A < B < C < D < E$.

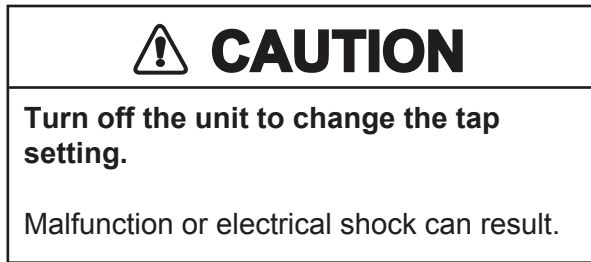

1. Remove the connector cover at the rear of the display unit.
2. Confirm that the unit is OFF and remove the tap setting connector which the transducer is connected.

When you install the transducers for low and high frequency, you need to set the tap setting respectively.

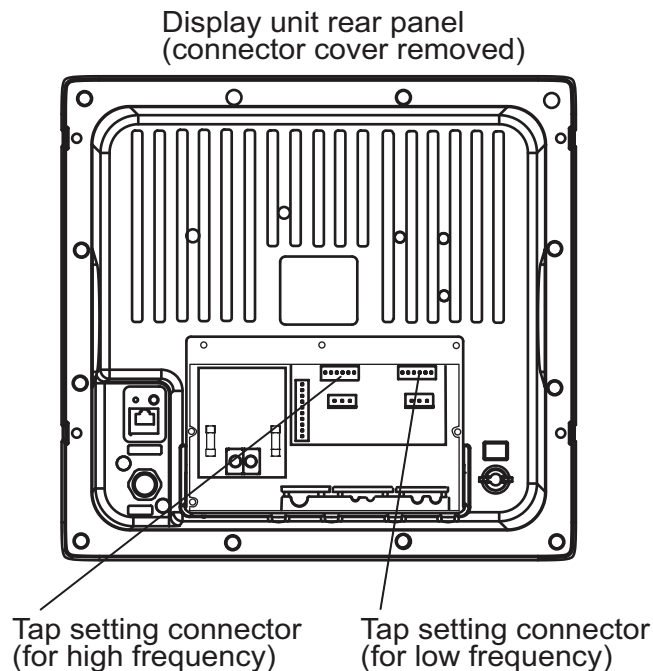

3. Connect between the common line and "A" line with the jumper line, reattach the tap setting connector.

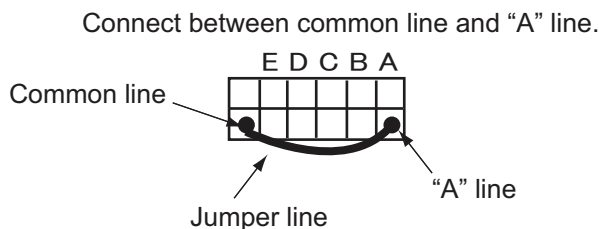

4. Turn on the unit and adjust the gain to stabilize the color of the bottom echo in middle colors. When the color of the bottom echo stabilized in middle color, go to step 6.

For the gain adjustment, rotate the GAIN HF or GAIN LF control or set [GAIN ADJ] on the Calib menu.

- When the color of the bottom echo is not stabilized in middle colors, confirm the multiple-echo at the deep see areas.

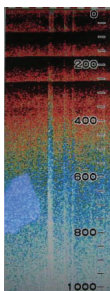

Display example: Multiple-echo

Set the range to integral multiple of the bottom, and then adjust the gain to stabilize the color of the multiple-echo in middle colors. The reverberation echo is available for the confirmation if the echo color is stable.

Note1: When the echo is weak in the tap setting “A”, the transducer may be malfunction. Turn off the unit.

Note2: When the symptoms as shown below appear, turn off the unit. Malfunction can result. Also when the symptoms as shown below appear in the tap setting “A”, the transducer connected to the unit is not available.

- The color of the bottom echo is not stabilized in middle colors.
- The depth indication is unstable.
- The bottom echo is interrupted.

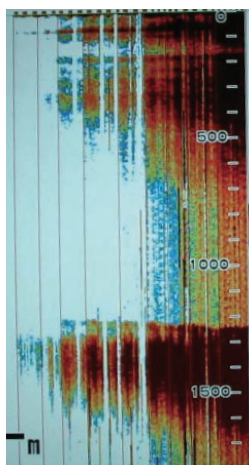

Display example: The bottom echo is interrupted.

- When the color of the bottom echo stabilized in middle color, record the color, gain value and setting value on [Gain ADJ].
- Turn off the unit and change the tap setting to the next level, then repeat steps 4 to 7.
(The output power of the tap setting; $A < B < C < D < E$.)

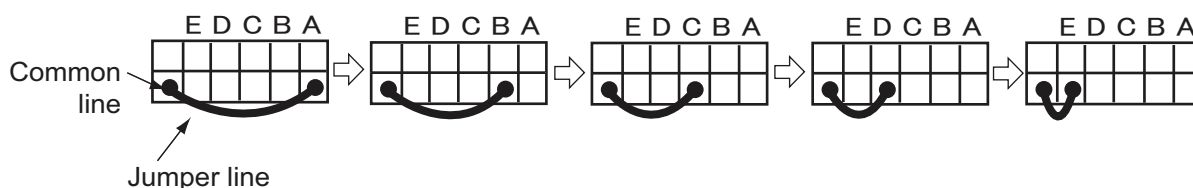

When the bottom echo is not stabilized in middle colors or interrupted, go to step 9.

8. Compare the gain value and setting value on [Gain ADJ] to the one level lower tap setting. When the gain value is more than 0.2 lower or the setting value on [Gain ADJ] is more than 1.0 lower than the value of one level lower tap setting, go to step 7. Otherwise go to next step.
9. Change the tap setting to the one level lower setting.
Note: When you do not change the tap setting to the one level lower setting, malfunction can result.
10. Reattach the tap setting connector and connector cover.

3.3 Speed/Water Temperature Sensor Calibration

If the optional speed and/or water temperature sensor is connected, set up as follows:

1. Turn on the power and press the **MENU** key.
 The main menu and sub-menu appears.
2. Press ▼ to select “System” and “Club” and then press the **ENTER** key.
3. Press ▼ to select “Temp” and then press the **ENTER** key.

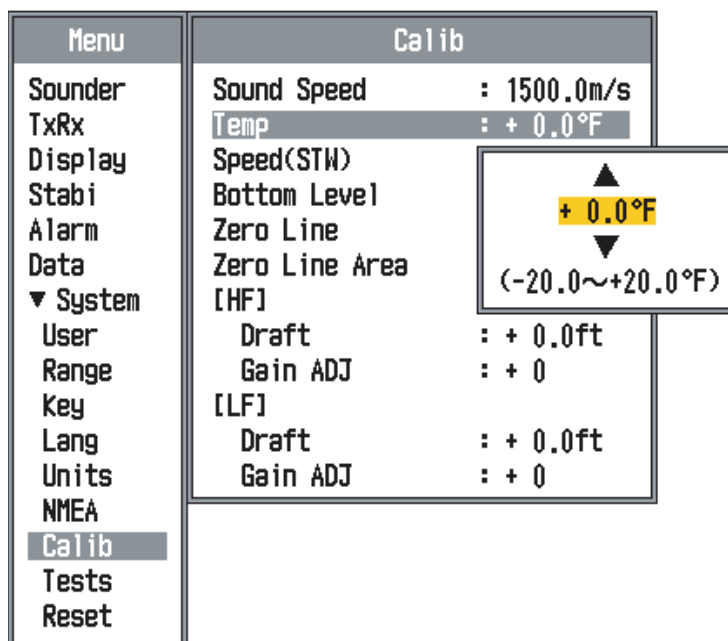

Temperature calibration screen

4. Press ▼ or ▲ to set the value for the temperature calibration and then press the **ENTER** key.
 For example, if the temperature indication is 2.5°C higher than the actual value, set “-2.5°C”.

5. To calibrate the speed value, press ▼ to select “Speedster”) and then press the **ENTER** key.

Menu	Calib
Sounder	Sound Speed : 1500.0m/s
TxRx	Temp : + 0.0°F
Display	Speed(STW) : + 0%
Stabi	Bottom Level
Alarm	Zero Line
Data	Zero Line Area
▼ System	[HF]
User	Draft
Range	Gain ADJ : + 0
Key	[LF]
Lang	Draft : + 0.0ft
Units	Gain ADJ : + 0
NMEA	
Calib	
Tests	
Reset	

6. Press ▼ or ▲ to set the value for the speed calibration and then press the **ENTER** key.

For example, if the speed indication is 5% lower than the actual value, set +5%.

7. To close the menu, press the **MENU/ESC** key twice.

3.4 NMEA Port Setting

If a GPS navigator and/or other sensor are connected, set up as follows.

1. Press the **MENU** key.

2. Press ▼ to select “System” and “NMEA” and then press the **ENTER** key.

Menu	NMEA
Sounder	NMEA0183 : Ver 2.0
TxRx	NMEA Port : In/Out
Display	NMEA Output : Off
Alarm	WAAS Setup : Off
Data	TLL Output : TLL
▼ System	Hardness Output: Off
User	Port Monitor
Range	
Key	
Lang	
Units	
NMEA	
Calib.	
Tests	
Reset	

NMEA setting menu

3. Press ▼ to select the item to set and then press the **ENTER** key.

4. Press ▼ or ▲ to select an appropriate one and then press the **ENTER** key.

Description for each item of the NMEA menu

NMEA0183: Choose NMEA0183 version of navigation equipment connected to the NMEA port, among Ver. 1.5, Ver. 2.0 or Ver. 3.0. "SPECIAL" is for use with a navigator whose baud rate is 600 bps.

Note: The [Echo] menu is for researchers, do not select [Echo] under normal conditions.

NMEA Port: The NMEA terminals in the NMEA port can function as input ports or input/output port. Change the setting to "In/In" when connecting GP-310B/320B and a wind sensor. When connecting the GP-320B and a wind sensor, first turn on "WAAS Setup" and then select "In/In" as the NMEA Port setting.

- In/Out: NMEA port J2 #1 & #2 is output port and J2 #3 & #4 is input port.
- In/In: NMEA port J2 #1 & #2 changes to input port. (Available with connection of the GP-310B/320B and a wind sensor.)

NMEA Output: Set the output data sentences.

- Off: Outputs the "output data sentences" (see page 9).
- On: Outputs the "output data sentences" of FCV-1150 and sentences which are input from other equipment.

WAAS Setup: Choose how to use the WAAS signal when connecting with a WAAS receiver, for example GP-320B. The message types (WAAS-00 to WAAS-27) are used as WAAS correction. Choose WAAS-00 to enable WAAS.

Note: Currently, WAAS is only available in North America, and Japan and it is in the developmental stage in Europe and Japan. During the developmental phase the reliability and availability of the WAAS signal cannot be guaranteed. Therefore, any position data should be verified against other sources to confirm reliability. This function is available only when In/Out is selected at NMEA Port.

TLL Output: Output the position specified by the **MARK** key to the plotter connected.

- Off: Does not output latitude/longitude.
- TLL: Outputs latitude/longitude.
- FURUNO-TLL: Outputs latitude/longitude, depth and water temperature. This requires FURUNO-TLL enabled device.

Hardness Output: When set to on, the hardness sentence (SDBHR) is output. When the transducer is set as "XDCLR Type" on the transducer settings screen, this sentence is always output. The hardness sentence is output on a 100ms cycle at the shortest, in accordance with this equipment's TX rate. If there is excessive traffic on the NMEA output, the hardness sentence output may be limited. The DPT sentence is the only depth data sentence used in this equipment.

Port Monitor: Port Monitor provides information for the data sentences input from the NMEA port. Press the **ENTER** key to display the latest data sentence information. To display this information on the Port 2 screen when two sensors are connected, set NMEA Port on the NMEA menu to In/In.

3.5 Heaving Setting

For the heaving feature to function correctly, set the distance between satellite compass antenna (GPS sensor) and transducer as follows.

1. Press the **MENU** key to display the main menu.
2. Press ▼ to select “Stabi” and then press the **ENTER** key.

Menu	Stabi
Sounder	Stabilization : Off
TxRx	Sensor : SC50/110
Display	Stabi. Area : 15
Accu Fish	[HF]
Stabi	TD fore-aft : 0.0
NavNet	TD port-stbd : 0.0
Alarm	ANT-TD height : 0.0
Data	[LF]
▶ System	TD fore-aft : 0.0
	TD port-stbd : 0.0
	ANT-TD height : 0.0

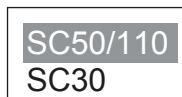

3. Press ▼ or ▲ to select “Stabilization” and then press the **ENTER** key.
4. Press ▼ to select “On” and then press the **ENTER** key.
5. Press ▼ to select “Sensor” and then press the **ENTER** key.



6. Select the type of satellite compass connected and then press the **ENTER** key.
7. Press ▼ to select “Stabi. Area” and then press the **ENTER** key.



8. Press ▼ or ▲ to select desired Stabi. Area and then press the **ENTER** key.

When heaving exceeds the value set here, stabilization is stopped and the stabilizer icon  at the top of the screen disappears. However, the heaving mode is kept “On”. When heaving is once again less than the value set here, stabilization is restarted and the stabilizer icon  reappears.

9. Set the distance between transducer(s) and antenna unit (or sensor) of the satellite compass as follows.

TD fore-aft: Set the distance from antenna unit to the transducer in fore-aft direction. When the transducer is located on the fore side, set a positive value.

TD port-stbd: Set the distance from antenna unit to the transducer in port-starboard direction. When the transducer is located on the starboard side, set a positive value.

ANT-TD height: Set the distance from the transducer to the antenna unit in the vertical direction.

Note: For the heaving feature, set the output of satellite compass SC-50/110/30 as follows.

	SC-50/110 (DATA OUT menu)	SC-30 (Set IF-NMEASC)
Sentence	ATT, HVE	ATT, HVE
Baud rate	38400 BPS	38400 BPS
Cycle	25 ms	25 ms
Format	IECED1	-

APPENDIX 1

TRANSDUCER 82B-35R

The 82B-35R is a transducer with wide bandwidth of 65 kHz-110 kHz. It is constructed to provide protection against slamming.

Transducer, thru-hull pipe and tank list

The contents in the table below are for your information only. Some tanks are not RoHS compliant.

Frquency (kHz)	Transducer	Hull Material	Tank (Code No.)	Fasten inside hull (Code No.)	Fasten outside hull (Code No.)
50/82	50F-8G/82B-35R	Steel	T-636 (000-015-813)	TWB-6000 (2) (000-015-207)	TFB-7000 (2) (000-015-209)
		FRP	T-636-F (000-015-814)	TRB-1100 (2) (000-015-218)	-
82/200	82B-35R/200B-8/ 200B-8B/200B-8N	Steel	T-649 (000-015-833)	TWB-6000 (2) (000-015-207)	TFB-7000 (2) (000-015-209)
		FRP	T-649-F (000-015-834)	TRB-1100 (2) (000-015-218)	-

Connection

Connect the 82B-35R transducer to either the "HF" or "LF" connector, referring to page S-1.

Tap Setting

Referring to page 13, set the tap to E.

Setting for dual frequency transmitting

1. Set the XDCR SELECT menu as follows (see page 12 and 13).

Setting for "HF" connection

XDCR Setting	
XDCR Select	: XDCR Type
HF Connection	: Connected
Freq	: 82 kHz
Transducer	: 82B-35R
Tap	: E
Freq	: ---kHz
Band width	: ---kHz
LF Connection	: Not Connected
Freq	: ---kHz
Transducer	: -----
Tap	: --
Freq	: ---kHz
Band width	: ---kHz
Tx Power	: Auto
Demonstrate	: Off
NavNet Mode	: Off

Setting for "LF" connection

XDCR Setting	
XDCR Select	: XDCR Type
HF Connection	: Not Connected
Freq	: ---kHz
Transducer	: -----
Tap	: --
Freq	: ---kHz
Band width	: ---kHz
LF Connection	: Connected
Freq	: 82 kHz
Transducer	: 82B-35R
Tap	: E
Freq	: ---kHz
Band width	: ---kHz
Tx Power	: Auto
Demonstrate	: Off
NavNet Mode	: Off

2. Press the [PWR] key to turn the power off, and turn it on again.
3. Press the **MENU** key to show the menu.
4. Select [Sounder] and press the **ENTER** key.
5. See the section "1.20.1 Sounder menu" in the Operator's Manual for how to set "Freq Choice" and "Freq Control" for high and low frequencies.

APPENDIX 2 INSTALLATION OF TEMPERATURE SENSORS

The installation instructions in this chapter are copied from the manufacturer's (AIRMAR Technology Corporation) installation guide, which is included with your sensor.

The model numbers mentioned within the documentation should be read as follows:

T42 => T-04MSB

T80 => T-04MTB

OWNER'S GUIDE & INSTALLATION INSTRUCTIONS

Thru-Hull, Analog High-Precision Temperature Sensor

Model T42

Record the information found on the cable tag for future reference.

Part No. _____ Date _____

05/28/14

17-437-402 rev. 01

Follow the precautions below for optimal product performance and to reduce the risk of property damage, personal injury, and/or death.

WARNING: Always wear safety goggles and a dust mask when installing.

WARNING: Immediately check for leaks when the boat is placed in the water. Do not leave the boat unchecked for more than three hours. Even a small leak can allow considerable water to accumulate.

CAUTION: Never install a bronze sensor in a metal hull because electrolytic corrosion will occur.

CAUTION: Never install a metal sensor on a vessel with a positive ground system.

CAUTION: Never pull, carry, or hold the sensor by its cable; this may sever internal connections.

CAUTION: Never use solvents. Cleaner, fuel, sealant, paint, and other products may contain solvents that can damage plastic parts, especially the sensor's face.

IMPORTANT: Read the instructions completely before proceeding with the installation. These instructions supersede any other instructions in your instrument manual if they differ.

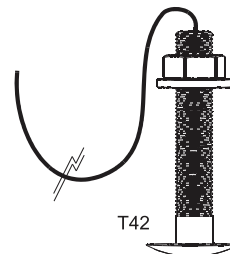

Tools & Materials

- Safety goggles
- Dust mask
- Electric drill
- Drill bit/hole saw/spade bit:
 - Pilot hole 3mm or 1/8"
 - T42 22mm or 7/8"
- Sandpaper
- Mild household detergent or weak solvent (alcohol)
- Marine sealant (suitable for below waterline)
- Slip-joint pliers
- Installation in a cored fiberglass hull (see page 2)
 - Hole saw for hull interior: 30mm or 1-1/4"
 - Cylinder, wax, tape, and casting epoxy
- Water-based anti-fouling paint (**mandatory in salt water**)

Sensor Installation

Hole Drilling

Cored fiberglass hull — Follow separate instructions on page 2.

- Drill a 3mm or 1/8" pilot hole from inside the hull. If there is a rib, strut, or other hull irregularity near the selected mounting location, drill from the outside.
- Using the appropriate drill bit, cut a hole perpendicular to the hull from outside the boat.
- Sand and clean the area around the hole, inside and outside, to ensure that the marine sealant will adhere properly to the hull. If there is any petroleum residue inside the hull, remove it with either mild household detergent or a weak solvent (alcohol) before sanding.

Applications

- Bronze sensor recommended for fiberglass or wood hull only.
- The hull must be a minimum of 8mm (5/16") thick at the mounting location.

Mounting Location

Choose a location where the temperature sensor will be in contact with the water at all times.

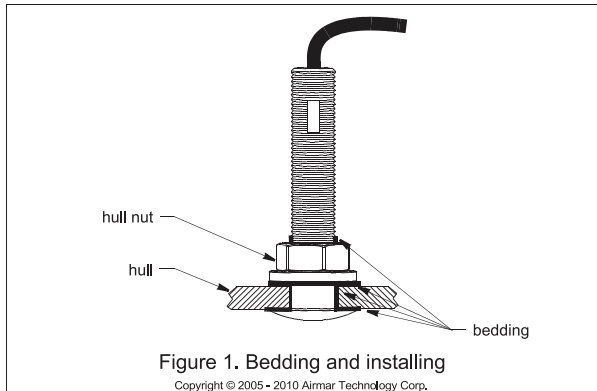

Bedding

CAUTION: Be sure all surfaces to be bedded are clean and dry.

1. Remove the hull nut (see Figure 1).
2. Apply a 2 mm (1/16") thick layer of marine sealant around the flange of the sensor that will contact the hull and up the stem. The sealant must extend 6 mm (1/4") higher than the combined thickness of the hull and the hull nut. This will ensure that there is marine sealant in the threads to seal the hull and hold the hull nut securely in place.
3. Apply a 2 mm (1/16") thick layer of marine sealant to the flange of the hull nut that will contact the hull.

Installing

1. From outside the hull, thread the cable through the mounting hole.
2. Push the sensor into the mounting hole using a twisting motion to squeeze out excess marine sealant (see Figure 1).
3. From inside the hull, slide the hull nut onto the cable. Screw the hull nut in place. Tighten it with slip-joint pliers.
Cored fiberglass hull—Do not over tighten, crushing the hull.
Wood hull—Allow for the wood to swell before tightening.
4. Remove any excess marine sealant on the outside of the hull to ensure smooth water flow over the sensor.

Checking for Leaks

When the boat is placed in the water, **immediately** check around the thru-hull sensor for leaks. Note that very small leaks may not be readily observed. Do not leave the boat in the water for more than 3 hours before checking it again. If there is a small leak, there may be considerable bilge water accumulation after 24 hours. If a leak is observed, repeat "Bedding" and "Installing" **immediately** (see page 2).

Cable Routing & Connecting

CAUTION: If the sensor came with a connector, do not remove it to ease cable routing. If the cable must be cut and spliced, use Airmar's splash-proof Junction Box No. 33-035 and follow the instructions supplied. Removing the waterproof connector or cutting the cable, except when using a water-tight junction box, will void the sensor warranty.

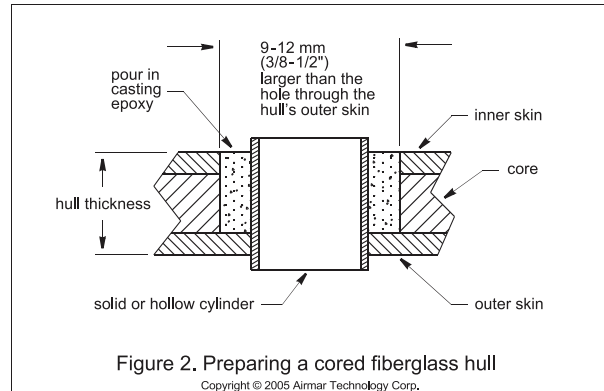

1. Route the cable to the instrument being careful not to tear the cable jacket when passing it through the bulkhead(s) and other parts of the boat. Use grommet(s) to prevent chafing. To reduce electrical interference, separate the transducer cable from other electrical wiring and the engine. Coil any excess cable and secure it in place with cable ties to prevent damage.
2. Refer to the instrument owner's manual to connect the transducer to the instrument.

Installation in a Cored Fiberglass Hull

The core (wood or foam) must be cut and sealed carefully. The core must be protected from water seepage, and the hull must be reinforced to prevent it from crushing under the hull nut allowing the sensor to become loose.

CAUTION: Completely seal the hull to prevent water seepage into the core.

1. Drill a 3mm or 1/8" pilot hole from inside the hull. If there is a rib, strut, or other hull irregularity near the selected mounting location, drill from the outside. (If the hole is drilled in the wrong location, drill a second hole in a better location. Apply masking tape to the outside of the hull over the incorrect hole and fill it with epoxy.)
2. Using the 21 mm or 7/8" drill bit, cut a hole from outside the hull through the *outer* skin only (see Figure 2).
3. From inside the hull using the 30mm or 1-1/4" hole saw, cut through the *inner* skin and most of the core. The core material can be very soft. Apply only light pressure to the hole saw after cutting through the inner skin to avoid accidentally cutting the *outer* skin.
4. Remove the plug of core material so the *inside* of the outer skin and the inner core of the hull is fully exposed. Clean and sand the inner skin, core, and the outer skin around the hole.
5. Coat a hollow or solid cylinder of the correct diameter with wax and tape it in place. Fill the gap between the cylinder and hull with casting epoxy. After the epoxy has set, remove the cylinder.
6. Sand and clean the area around the hole, inside and outside, to ensure that the sealant will adhere properly to the hull. If there is any petroleum residue inside the hull, remove it with either mild household detergent or a weak solvent (alcohol) before sanding.
7. Proceed with "Bedding" and "Installing" (see page 2).

OWNER'S GUIDE & INSTALLATION INSTRUCTIONS

Surface Mount, Analog

Temperature Sensor

Model T80

Record the information found on the cable tag for future reference.

Part No. _____ Date _____

05/28/14

17-584-01 rev. 01

Follow the precautions below for optimal product performance and to reduce the risk of property damage, personal injury, and/or death.

WARNING: Always wear safety goggles and a dust mask when installing.

WARNING: Below the waterline mount—When the boat is placed in the water, immediately check for leaks around the screws and any other holes drilled in the hull.

CAUTION: Installation on a metal hull—The stainless steel housing must be isolated from a metal hull to prevent electrolytic corrosion. Use marine sealant.

CAUTION: Never install a metal sensor on a vessel with a positive ground system.

IMPORTANT: Read the instructions completely before proceeding with the installation. These instructions supersede any other instructions in your instrument manual if they differ.

Applications

- Measures air or water temperature.
- Stainless steel sensor is compatible with all hull materials. Recommended for aluminum hulls to prevent electrolytic corrosion, provided the stainless steel sensor is isolated from the metal hull by using marine sealant.

Mounting Location

The sensor can be mounted anywhere that you want to know the temperature. For example, you can mount the sensor on the transom, in the live well, or in the engine compartment.

If you are measuring water temperature, choose a location where the sensor will be in contact with the water at all times.



Tools & Materials

- Safety goggles
- Dust mask
- Pencil
- Electric drill
- Drill bit/hole saw/spade bit:
 - Pilot holes 3 mm or 1/8"
 - Transom hole (some installations) 18 mm or 3/4"
- 2 Stainless steel, self-tapping screws 4 x 18 mm or #8 x 3/4"
- Marine sealant (suitable for below waterline)
- Screwdriver(s)
- Cable clamp(s) (some installations)
- Grommet(s) (some installations)
- Cable ties

Installation

Mounting on the transom

CAUTION: Mount the sensor as close to the centerline (keel) of the boat as possible to ensure the sensor remains in the water when the boat is turning (see Figure 1).

CAUTION: Fiberglass hull—Minimize surface cracking by running the drill in reverse until the gelcoat is penetrated.

CAUTION: If the sensor came with a connector, do not remove it to ease cable routing. If the cable must be cut and spliced, use Airmar's splash-proof Junction Box No. 33-035 and follow the instructions provided. Removing the waterproof connector or cutting the cable, except when using a water-tight junction box, will void the sensor warranty.

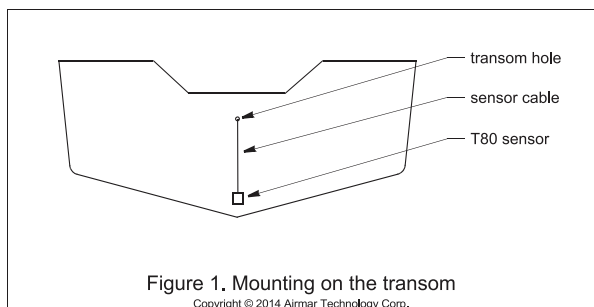

Mount the sensor near the centerline and close to the bottom of the transom.

Route the sensor cable over the transom, through a drain hole, or through a hole that you have drilled in the transom **above the waterline**.

1. Place the sensor against the hull and mark the position of the screw holes with a pencil.
2. Using a 3mm or 1/8" drill bit, drill pilot holes at the marked locations, 10mm (3/8") deep.
3. Apply marine sealant to the threads of the purchased screws to prevent water from seeping into the transom.
4. Screw the temperature sensor to the hull.
5. If a hole must be drilled through the transom, choose a location **well above the waterline**. Check for obstructions such as trim tabs, pumps, or wiring inside the hull. Mark the location with a pencil. Drill a hole through the transom using the appropriate size hole saw or spade bit (to accommodate the connector). Do NOT remove the connector.
6. Route the cable over or through the transom.
7. On the outside of the hull, secure the cable against the transom using a purchased cable clamp(s). Mark the position of the screw hole(s) with a pencil.
8. Using a 3mm or 1/8" drill bit, drill a pilot hole(s) at the marked locations, 10mm (3/8") deep.
9. Apply marine sealant to the threads of the screw(s) to prevent water from seeping into the transom.
10. Fasten the cable clamp(s) in place.
11. If a hole has been drilled through the transom, apply marine sealant to the space around the cable leading through the transom.

Cable Routing & Connecting

1. Route the cable to the instrument, being careful not to tear the cable jacket when passing it through the bulkhead(s) and other parts of the boat. To reduce electrical interference, separate the sensor cable from other electrical wiring and sources of noise. Coil any excess cable and secure it in place with cable ties to prevent damage.
2. Refer to the instrument owner's manual to connect the sensor to the instrument.

Replacement Sensor & Parts

The information needed to order a replacement sensor is printed on the cable tag. Do not remove this tag. When ordering, specify the part number and date. For convenient reference, record this information at the top of page one.

Obtain parts from your instrument manufacturer or marine dealer.

Gemeco
(USA)

Tel: 803-693-0777
Fax: 803-693-0477
email: sales@gemeco.com

Airmar EMEA
(Europe, Middle East, Africa)

Tel: +33.(0)2.23.52.06.48
Fax: +33.(0)2.23.52.06.49
email: sales@airmar-emea.com



35 Meadowbrook Drive, Milford, New Hampshire 03055-4613, USA
•www.airmar.com

PACKING LIST FCV-1150-J/E

02GD-X-9851-7

1/1

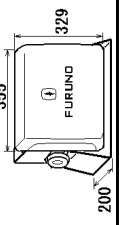
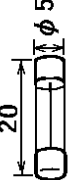
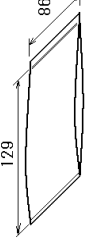
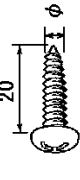
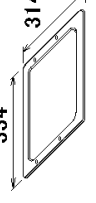
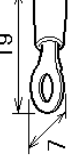
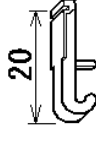
NAME	OUTLINE	DESCRIPTION/CODE No.	Q'TY
UNIT			
ユニット			
指示器		CV-1150	1
DISPLAY UNIT		000-011-708-00 **	
SPARE PARTS			
予備品		SP02-05401	
ヒューズ		FGMB-S 125V 7A PBF	4
GLASS TUBE FUSE		000-157-493-10	
ACCESSORIES			
付属品		FP02-05700	
フィルターナー		02-155-1082-2	1
LCD CLEANING CLOTH		100-332-652-10	
INSTALLATION MATERIALS			
工事材料		CP02-08301	
+トラスカピロネジ 1シユ		5X20 SUS304	5
SELF-TAPPING SCREW		000-162-608-10	
Fマウントボスナジ		02-157-1302-0	1
FLUSH MOUNTING SPONGE		100-342-010-10	
圧着端子		FV2-M4 K	2
CRIMP-ON LUG		000-157-229-11	
操作レバ-		231-131	1
TERMINAL OPENER		000-165-800-11	

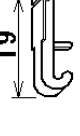
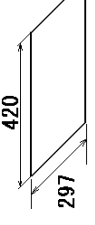
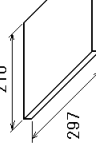
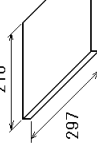
NAME	OUTLINE	DESCRIPTION/CODE No.	Q'TY
操作レバ-		734-230	1
TERMINAL OPENER		000-147-417-10	
DOCUMENT			
フラッシュマウント型紙		C22-00702 * 7/E1	1
FLUSH MOUNTING TEMPLATE		000-167-736-1*	
取扱説明書		OM*-23780 *	1
OPERATOR'S MANUAL		000-167-728-1* **	
装備要領書		IM*-23780 *	1
INSTALLATION MANUAL		000-167-732-1* **	

(略図の寸法は、参考値です。DIMENSIONS IN DRAWING FOR REFERENCE ONLY.)

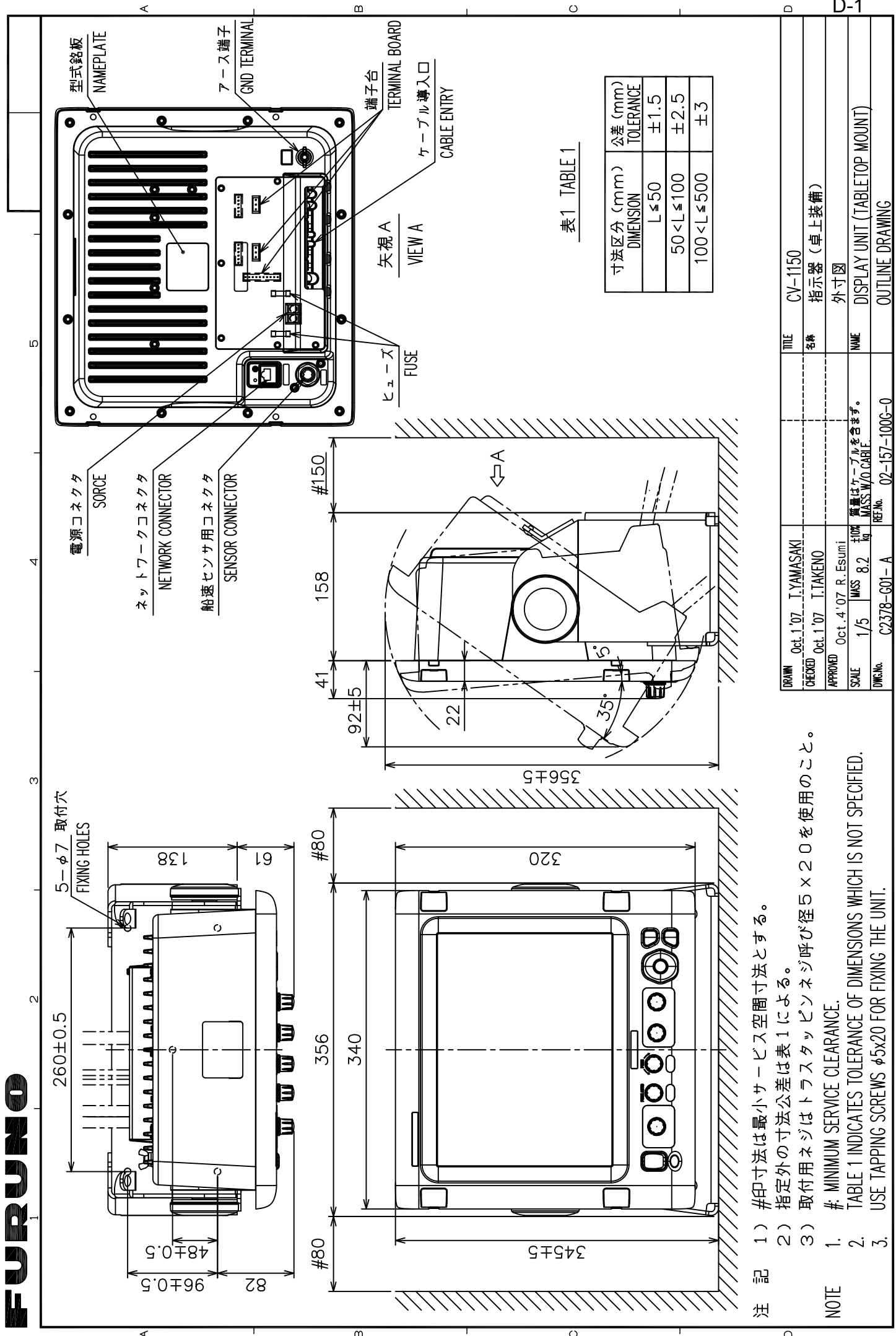

注 記 1) #印寸法は最小サービス空間寸法とする。
 2) 指定外の寸法公差は表1による。
 3) 取付用ネジはトラスタップピンネジ呼び径5×20を使用のこと。

NOTE 1. # MINIMUM SERVICE CLEARANCE.
 2. TABLE 1 INDICATES TOLERANCE OF DIMENSIONS WHICH IS NOT SPECIFIED.
 3. USE TAPPING SCREWS φ5x20 FOR FIXING THE UNIT.

DRAWN	Oct. 1 '07	I. YAMASAKI	TITLE	CV-1150
CHECKED	Oct. 1 '07	I. TAKENO	名称	指示器 (卓上装備)
APPROVED	Oct. 4 '07	R. Esumi	外寸図	
SCALE	1/5	質量はケーブルを含みず。 MASS W/O CABLE	NAME	DISPLAY UNIT (TABLETOP MOUNT)
DWG. No.	C2378-G01-A	REF. No.	02-157-100G-0	OUTLINE DRAWING

表1 TABLE 1

寸法区分 (mm) DIMENSION	公差 (mm) TOLERANCE
L ≤ 50	±1.5
50 < L ≤ 100	±2.5
100 < L ≤ 500	±3

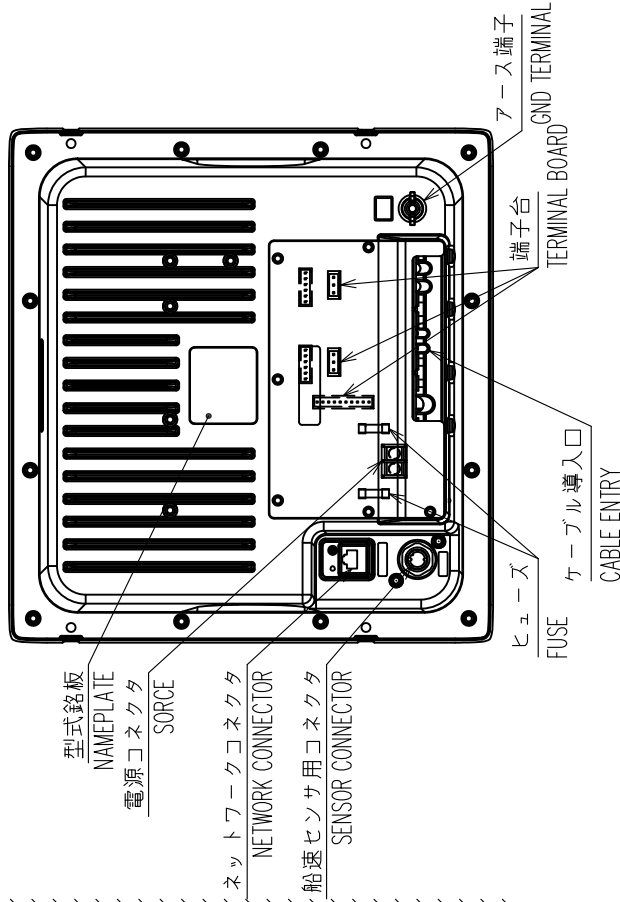
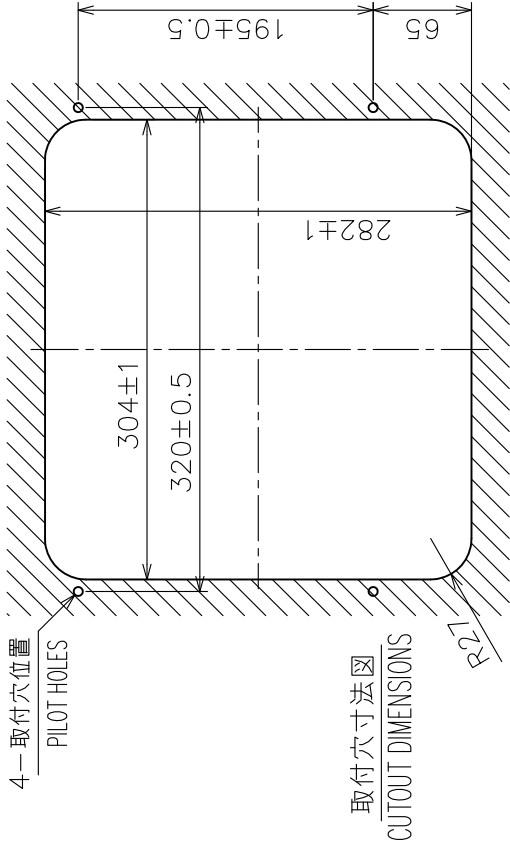
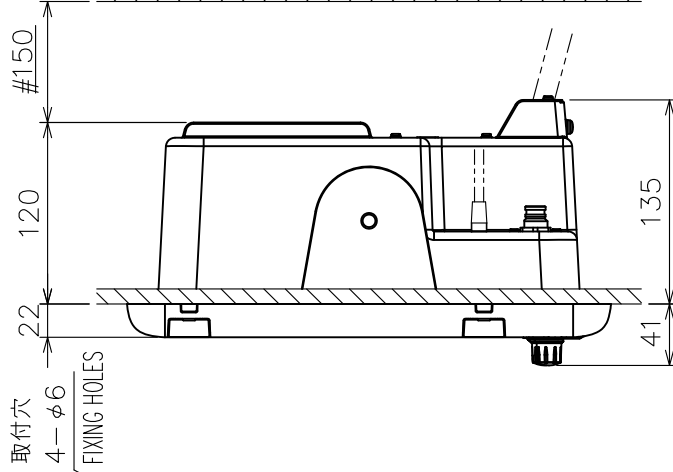
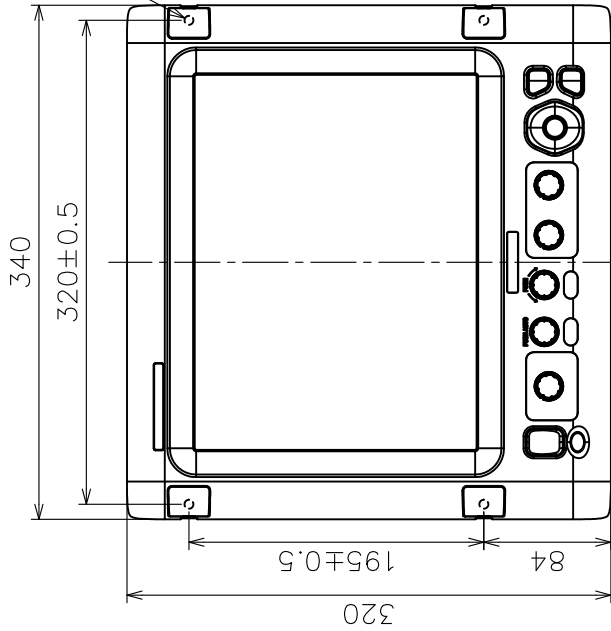
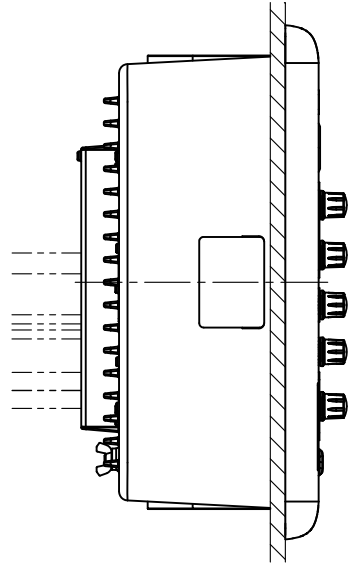

DRAWN	Oct.1'07	I.YAMASAKI	TITLE	CV-1150
CHECKED	Oct.1'07	I.TAKENO	名称	指示器 (埋込装備)
APPROVED	Oct.3'07	R.Esumi	外寸図	
SCALE	1/5	質量はケーブルを含まず。 ±0% MASS W/O CABLE	NAME	DISPLAY UNIT (FLUSH MOUNT)
DWG.No.	C2378-G02-A	REF.No.	02-157-110G-1	OUTLINE DRAWING

- 注記
- 1) #印寸法は最小サービス空間寸法とする。
 - 2) 指定外の寸法公差は表1による。
 - 3) 取付用ネジはトラスタッピンネジ呼び径5×20を使用のこと。
- NOTE
1. #: MINIMUM SERVICE CLEARANCE.
 2. TABLE 1 INDICATES TOLERANCE OF DIMENSIONS WHICH IS NOT SPECIFIED.
 3. USE TAPPING SCREWS φ5x20 FOR FIXING THE UNIT.

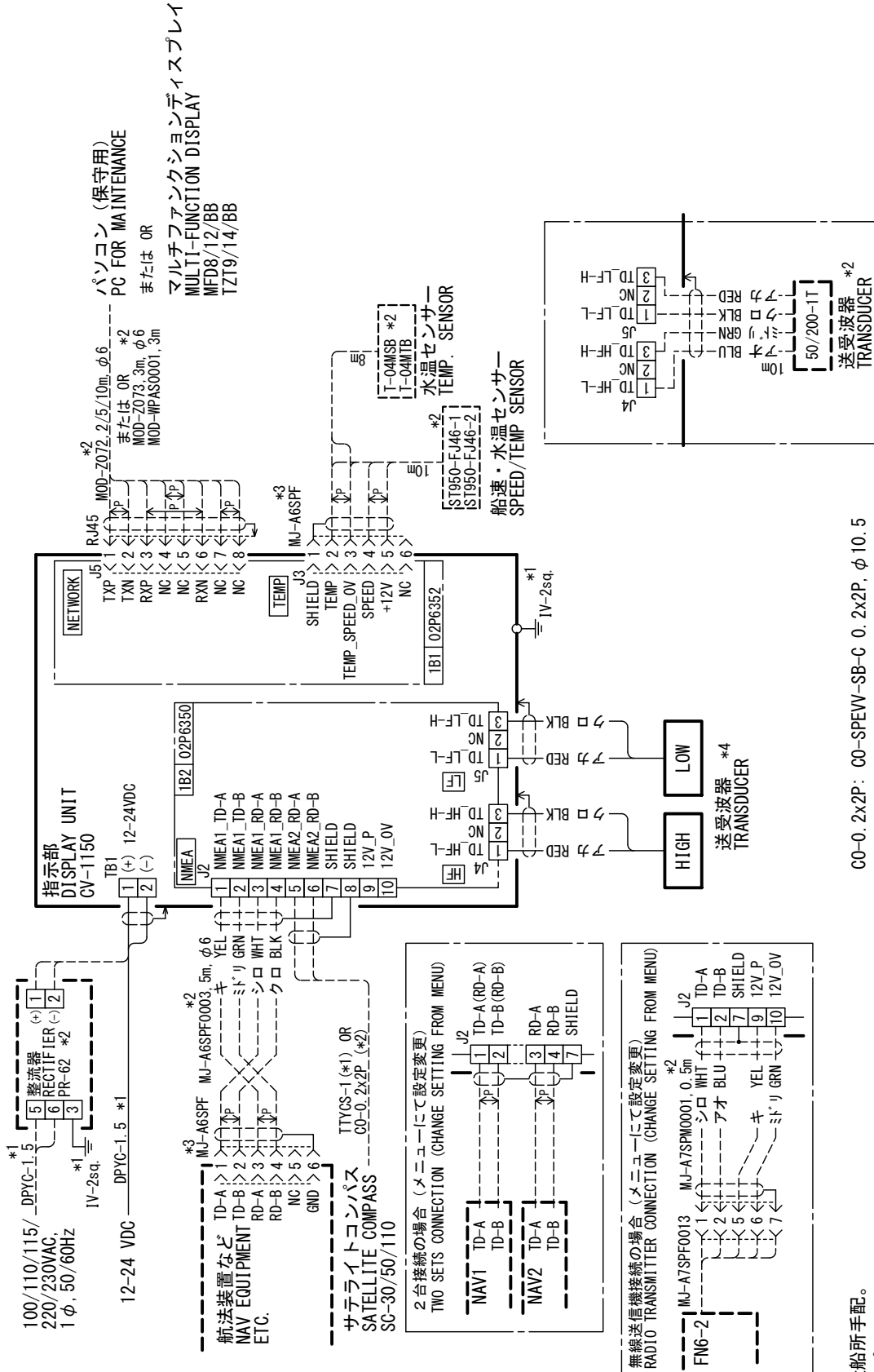

CO-0.2x2P: CO-SPEW-SB-C 0.2x2P, φ10.5

- 注記**
- * 1) 造船所手配。
 - * 2) オプション。
 - * 3) コネクタは工場にて取付済み。
 - * 4) 送受波器82B-35RはHF/LFのいずれかに接続。
- NOTE**
- *1: SHIPYARD SUPPLY.
 - *2: OPTION.
 - *3: CONNECTOR PLUG FITTED AT FACTORY.
 - *4: CONNECT THE 82B-35R TRANSDUCER TO EITHER HF OR LF.

DRAWN	13/Feb/2023	S. HAN	TITLE	FCV-1150
CHECKED	13/Feb/2023	T. YAMASAKI	名称	カラー魚群探知機
APPROVED	14/Feb/2023	H. MAKI		相互結線図
SCALE		MASS	NAME	COLOR LCD SOUNDER
DWG. No.	C2378-C01-L		REF. No.	A02-157-1001-1
				INTERCONNECTION DIAGRAM

FURUNO ELECTRIC CO., LTD.

9-52 Ashihara-cho,
Nishinomiya, 662-8580, JAPAN

• FURUNO Authorized Distributor/Dealer

All rights reserved. Printed in Japan

Pub. No. IME-23780-K

(YOTA) FCV-1150

A : DEC. 2007

K : MAR. 15, 2023



0 0 0 1 6 7 7 3 3 1 9