

Installation Manual

U-AIS TRANSPONDER

Model FA-150

SAFETY INSTRUCTIONS	i
SYSTEM CONFIGURATION	ii
EQUIPMENT LISTS.....	iii
1. MOUNTING.....	1-1
1.1 Antenna Units	1-1
1.2 Monitor Unit.....	1-11
1.3 UAIS Transponder	1-13
1.4 Power Supply (option).....	1-14
1.5 Pilot Plug (option).....	1-14
2. WIRING.....	2-1
2.1 Connection.....	2-1
2.2 Changing Ship's Mains Specifications	2-4
3. SETTING AND ADJUSTMENT	3-1
3.1 Inland AIS Specific Settings.....	3-1
3.2 How to Set MMSI, IMO No., Name and Call Sign.....	3-4
3.3 How to Set GPS Antenna Position.....	3-5
3.4 How to Set Ship Type	3-6
3.5 How to Set I/O Port.....	3-6
3.6 How to Set Long Range Channel	3-10
4. ATTACHING LAN KIT (OPTION).....	4-1
5. IEC 61162-1/2 DATA SENTENCES	5-1
APPENDIX 1 JIS CABLE GUIDE	AP-1
PACKING LISTS	A-1
OUTLINE DRAWINGS	D-1
INTERCONNECTION DIAGRAM	S-1



FURUNO ELECTRIC CO., LTD.

www.furuno.com

All brand and product names are trademarks, registered trademarks or service marks of their respective holders.

ECF

(Elemental Chlorine Free)

The paper used in this manual
is elemental chlorine free.

FURUNO ELECTRIC CO., LTD.

9-52 Ashihara-cho,
Nishinomiya, 662-8580, JAPAN

• FURUNO Authorized Distributor/Dealer

All rights reserved. Printed in Japan

Pub. No. IME-44310-P1

(ETMI) FA-150

A : NOV. 2004

P1 : MAR. 20, 2019



0 0 0 1 9 1 8 8 6 1 3



SAFETY INSTRUCTIONS

The installer must read the safety instructions before attempting to install this equipment.



WARNING

Indicates a potentially hazardous situation which, if not avoided, could result in death or serious injury.



CAUTION

Indicates a potentially hazardous situation which, if not avoided, can result in minor or moderate injury.



Warning, Caution



Prohibitive Action



Prohibitive Action



WARNING



ELECTRICAL SHOCK HAZARD
Do not open the equipment unless totally familiar with electrical circuits and service manual.

Only qualified personnel should work inside the equipment.



Turn off the power at the switchboard before beginning the installation.

Fire or electrical shock can result if the power is left on.



Do not install the equipment where it may get wet from rain or water splash.

Water in the equipment can result in fire, electrical shock or damage the equipment.



Be sure that the power supply is compatible with the voltage rating of the equipment.

Connection of an incorrect power supply can cause fire or damage the equipment. The voltage rating of the equipment appears on the label above the power connector.



CAUTION



Observe the following compass safe distances to prevent interference to a magnetic compass:

	Standard compass	Steering compass
FA-1501 UAIS Transponder	1.2 m	0.8 m
FA-1502 Monitor unit	0.45 m	0.3 m
GVA-100-T	0.3 m	0.3 m
DB-1	0.3 m	0.3 m
PR-240	0.9 m	0.6 m



Attach securely protective earth to the ship's body.

The protective earth is required to the power supply to prevent electrical shock.

SYSTEM CONFIGURATION

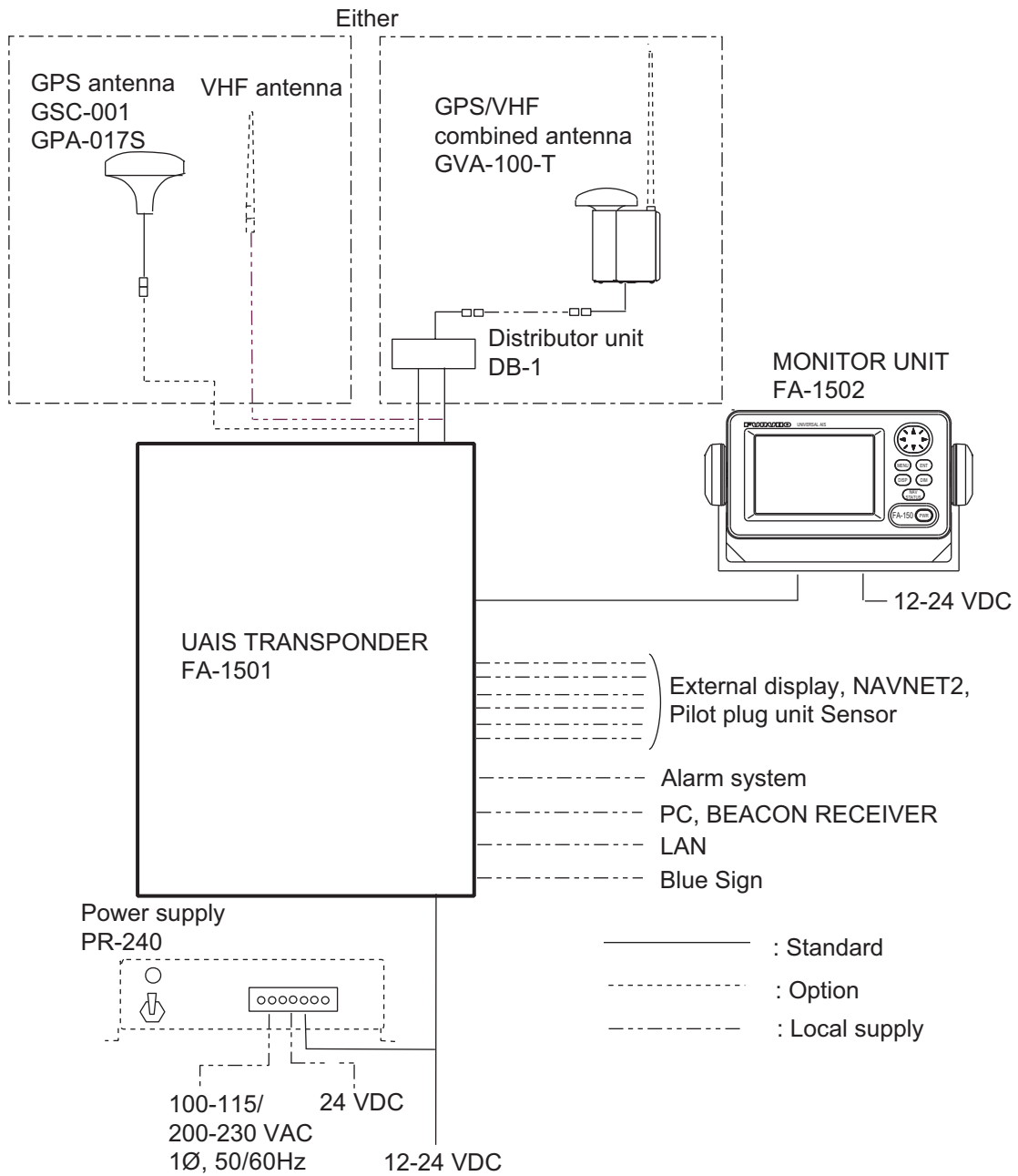

Category of the units

GSC-001	Exposed to the weather
GPA-017S	Exposed to the weather
GVA-100-T	Exposed to the weather
FA-1501	Protected from the weather
FA-1502	Protected from the weather
DB-1	Protected from the weather
PR-240	Protected from the weather

EQUIPMENT LISTS

Standard supply

Name	Type	Code no.	Qty	Remarks
UAIS Transponder	FA-1501	-	1	
Monitor Unit	FA-1502	-	1	
GPS Antenna	GSC-001	-	1	Select one.
	GPA-017S	-	1	
GPS/VHF Combined Antenna	GVA-100-T	-	1	
Distributor Unit	DB-1	-	1	
Installation Materials	MJ-A10SPF0012-050+	001-122-900-10	1	Cable for FA-1501
	CP24-00501	005-956-010	1	For FA-1501 (Type: 5x20 SUS304, 4 pcs. Code: 000-162-608-10)
	CP24-00400	001-058-240	1	Cable for FA-1502 (Type: MJ-A3SPF0013-035 Code: 000-135-397)
	CP14-06001	001-058-230	1	For FA-1502 (Type: 5x20 SUS304, 4 pcs. Code: 000-162-608-10)
	CP24-00101	005-950-730	1	For DB-1 (Type: 4x30 SUS304, 2 pcs. Code: 000-162-659-10)
	CP24-00110	000-053-878	1	For GVA-100-T
	CP24-00502	005-955-560	1	For GPA-017S/GSC-001
Accessories	FP14-02801	001-058-250	1	For FA-1502 (Type: 20-022-3017-0 Code: 100-337-240-10)
Spare Parts	SP24-00101	001-163-760	1	For FA-1502 (Type: FGBO-A 125V 3A PBF, 2 pcs. Code: 000-155-850-10)

Optional supply

Name	Type	Code no.	Remarks	
Monitor unit	FA-1502	-		
Antenna cable set	CP20-02700	004-381-160	8D-FB-CV(30m)+CP20-02701	
	CP20-02720	001-207-990	8D-FB-CV(40m)+CP20-02701	
	CP20-02710	004-381-170	8D-FB-CV(50m)+CP20-02701	
Antenna cable set	CP24-00300	000-041-938	8D-FB-CV(30m)+CP24-00301	
	CP24-00320	000-022-637	8D-FB-CV(40m)+CP24-00301	
	CP24-00310	000-041-939	8D-FB-CV(50m)+CP24-00301	
Coaxial cable	TNC-PS/PS-3D-L15M-R	000-133-670-12	TNC-TNC, 15m	
Mast mount fixture	CP20-01111	004-365-780	For GSC-001/GPA-017S	
Right-angle antenna base	No.13-QA330	001-111-910-10	For GSC-001/GPA-017S	
L-angle antenna base	No.13-QA310	001-111-900-10	For GSC-001/GPA-017S	
Antenna base for rail mount	No.13-RC5160	001-111-920-10	For GSC-001/GPA-017S	
Whip antenna	CX4-3/FEC	001-474-340-00		
	FAB-151D	001-144-490-10		
Antenna Fixing Bracket	N173F/FEC	001-474-350-00	For CX4-3/FEC (φ49-90)	
	N174F/FEC	001-494-890-00	For CX4-3/FEC (φ30-61)	
	CP05-14001	001-430-360	Bracket M-15AS1	
AC-DC power supply	PR-240	000-013-632	Include installation materials CP24-00151	
Pilot plug	OP24-3	000-053-911		
AD Converter	AD-100	-	For gyrocompass	
Cable assy.	MJ-A10SPF0012-050+	001-122-900-10	5 m	Transponder-display, connector attached at one end
	MJ-A10SPF0012-100+	001-122-910-10	10 m	
	MJ-A10SPF0012-250+	001-122-930-10	25 m	
	MJ-A10SPF0012-500+	001-122-940-10	50 m	
	MJ-A10SPF0012-1000+	001-122-920-10	100 m	
Flush mount kit S	OP20-17	000-040-720	For monitor unit	
Flush mount kit F	OP20-29	000-041-405		
φ80 Mast mount kit	OP24-5	005-954-510	For GVA-100-T	
GPS antenna	GSC-001-FA-T	000-041-929		
LAN kit	OP24-8	005-956-020	See page 4-1.	
UAIS display software	FAISPC MARK-2	005-860-470		
Distributor Unit	DB-1	-		

1. MOUNTING

NOTICE

Do not apply paint, anti-corrosive sealant or contact spray to coating or plastic parts of the equipment.

Those items contain organic solvents that can damage coating and plastic parts, especially plastic connectors.

1.1 Antenna Units

1.1.1 GPS antenna unit

Install the GPS antenna unit referring to the drawing on page D-5 or D-6 at the back of this manual. When selecting a mounting location for the antenna, keep in mind the following points.

- Select a location out of the radar beam. The radar beam will obstruct or prevent reception of the GPS satellite signal.
- There should be no interfering object within the line-of-sight to the satellites. Objects within line-of-sight to a satellite, for example, a mast, may block reception or prolong acquisition time.
- Mount the antenna unit as high as possible to keep it free of interfering objects and water spray, which can interrupt reception of GPS satellite signal if the water freezes.

How to extend antenna cable

Three types of antenna cable extensions are optionally available.

a) Antenna cable set CP20-02700

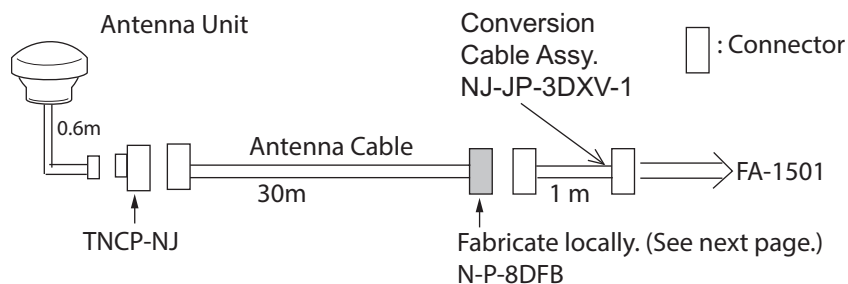

● Waterproofing connector

Wrap connector with vulcanizing tape and then vinyl tape. Bind the tape end with a cable-tie.



Waterproofing connector

- ##### b) Antenna cable set CP20-02720 (8D-FB-CV, 40m)/CP20-02710 (8D-FB-CV, 50m) Connect the cable the same as a) above.

1. MOUNTING

c) Cable type RG-10/UY (shipyard supply)

Note: The length of this cable should be less than 20 m to prevent signal loss. The coax. coupling cable assy.(type: NJ-TP+3DXV-1, code no. 000-123-809-10), coaxial connector (N-P-8DFB; supplied), vulcanizing tape and vinyl tape are required. Fabricate both ends of the cable as shown in the figure on the next page.

How to attach the connector N-P-8DFB for cable 8D-FB-CV

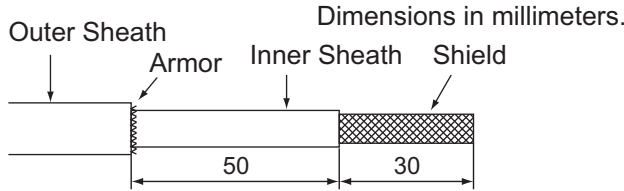

Remove outer sheath and armor by the dimensions shown left. Expose inner sheath and shield by the dimensions shown left.

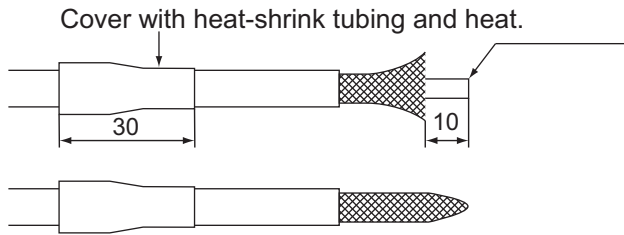

Remove insulator and core by 10 mm.

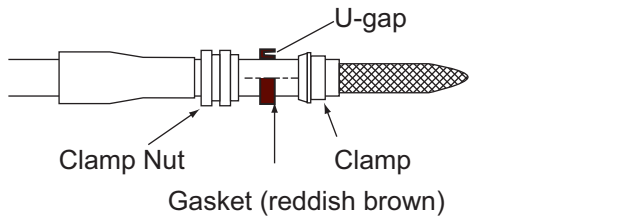

Twist shield end.

Slip on clamp nut, gasket and clamp as shown left.

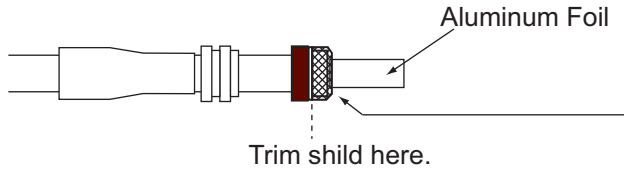

Fold back shield over clamp and trim.

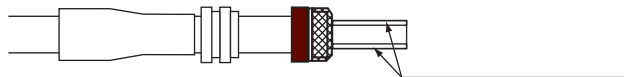

Cut aluminum foil at four places, 90° from each other.

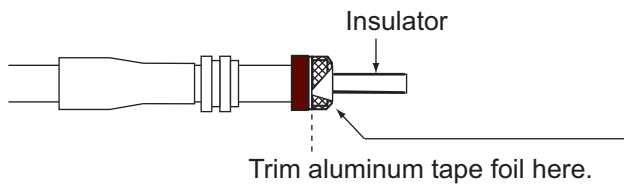

Fold back aluminum tape foil onto shield and trim.

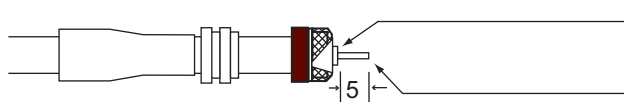

Expose the insulator by 1 mm.

Expose the core by 5 mm.

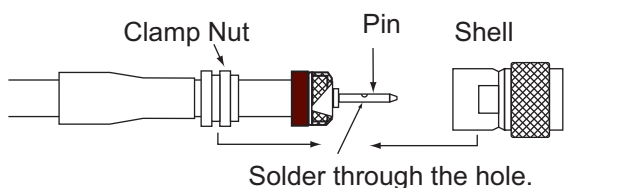

Slip the pin onto the conductor. Solder them together through the hole on the pin.

Insert the pin into the shell. Screw the clamp nut into the shell. (Tighten by turning the clamp nut. Do not tighten by turning the shell)

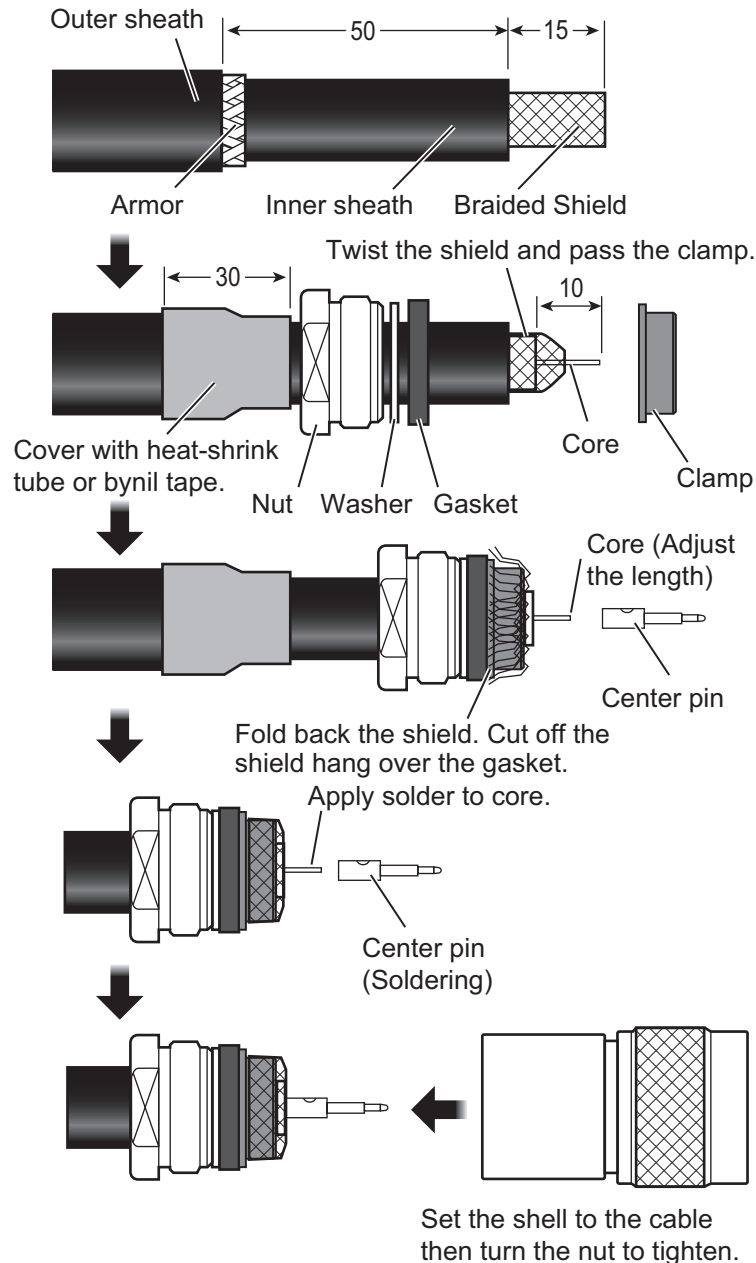
How to attach the connector N-P-8DSFA for cable 8D-FB-CV**1.1.2 VHF antenna****Location**

The location of the mandatory AIS VHF-antenna should be carefully considered. Digital communication is more sensitive than analog/voice communication to interference created by reflections in obstructions like masts and booms. It may be necessary to relocate the VHF radiotelephone antenna to minimize interference effects.

To minimize interference effects, the following guidelines apply:

- The AIS VHF antenna should be placed in an elevated position that is as free as possible with a minimum of 0.5 meters in the horizontal direction from constructions made of conductive materials. The antenna should not be installed close to any large vertical obstruction. The objective for the AIS VHF antenna is to see the horizon freely through 360 degrees.

1. MOUNTING

- The AIS VHF antenna should be installed safely away from interfering high-power energy sources like radar and other transmitting radio antennas, preferably at least 3 meters away from and out of the transmitting beam.
- There should not be more than one antenna on the same plane. The AIS VHF antenna should be mounted directly above or below the ship's primary VHF radiotelephone antenna, with no horizontal separation and with a minimum of 2.8 meters vertical separation. If it is located on the same plane as other antennas, the distance apart should be at least 10 meters.

Cabling

- The cable should be kept as short as possible to minimize signal attenuation. Coaxial cables equal to or better than RG10U/Y are recommended.
- All outdoor-installed connectors on coaxial cables should be fitted with preventive isolation such as vulcanizing tape to protect against water penetration into the antenna cable. Also, apply adhesive at the antenna base to prevent water intrusion from the screw part of antenna base.
- Coaxial cables should be installed in separate signal cable channels/tubes and at least 10 cm away from power supply cables. Crossing of cables should be done at right angles (90°). The minimum bend radius of the coaxial cable should be 5 times the cable's outer diameter.
- Install the VHF whip antenna referring to the outline drawing at the back of this manual. Separate this antenna from other VHF radiotelephone antennas as shown on the next page to prevent interference to the FA-150.

<Horizontal separation distance>

Horizontal separation distance

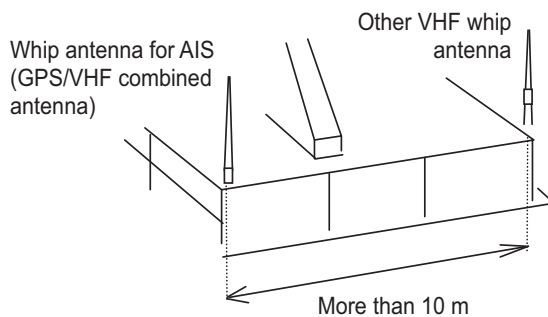

Vertical separation distance

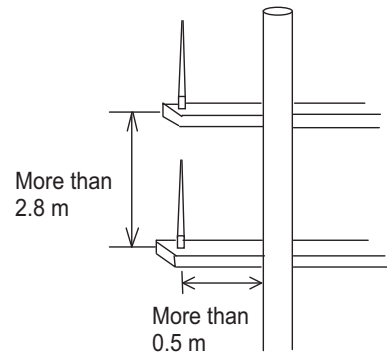

When coaxial cable RG-10/UY (shipyard supply) is used, attach the coaxial plug M-P-7 (dockyard supply) as shown below.

How to attach the plug M-P-7

Lay the coaxial cable and attach an M-type plug (if necessary) to the cable as follows.

1. Remove the sheath by 30 mm.
2. Bare 23 mm of the center conductor. Trim braided shield by 5 mm and tin.
3. Slide coupling ring onto cable.
4. Screw the plug assembly on the cable.
5. Solder plug assembly to braided shield through solder holes. Solder contact sleeve to conductor.
6. Screw coupling ring into plug assembly.

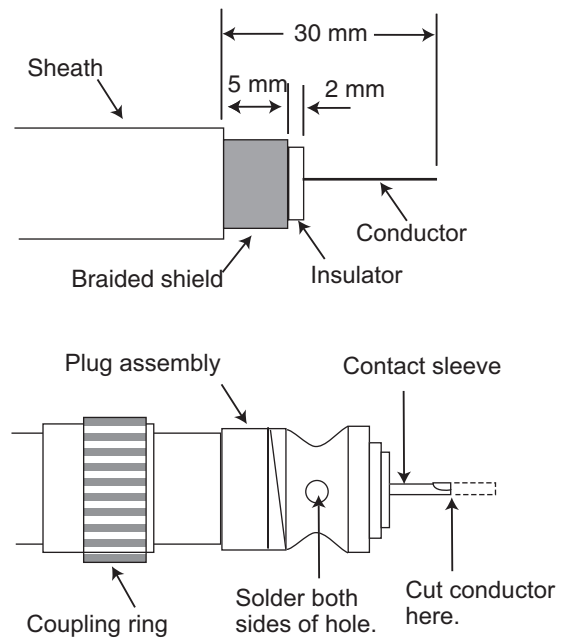
**1.1.3 GPS/VHF combined antenna**

Install the combined antenna unit referring to the outline drawing. When selecting a mounting location for the antenna, keep in mind the following points.

- Select a location out of the radar beam. The radar beam will obstruct or prevent reception of the GPS satellite signal.
- There should be no interfering object within the line-of-sight to the satellites. Objects within line-of-sight to a satellite, for example, a mast, may block reception or prolong acquisition time.
- Mount the antenna unit as high as possible. Mounting it this way keeps it free of interfering objects and water spray, which can interrupt reception of GPS satellite signal if the water freezes.
- Also, refer to the antenna installation guidelines on page 1-3.

1. MOUNTING

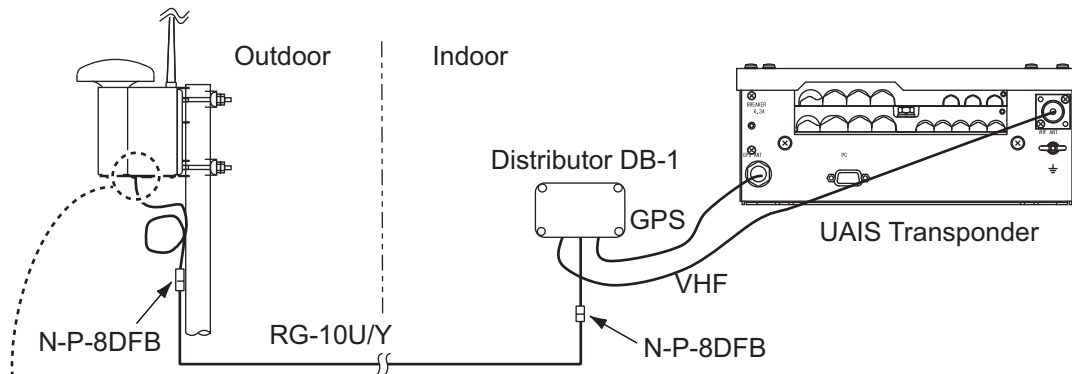

Detach the heat-resistant clamp (Name: KCA-44, Parts Code: 000-108-852-10) and wrap the vinyl tape 1.5 turns around the gray cable at the location where the clamp holds the cable, to prevent the cable from slipping.

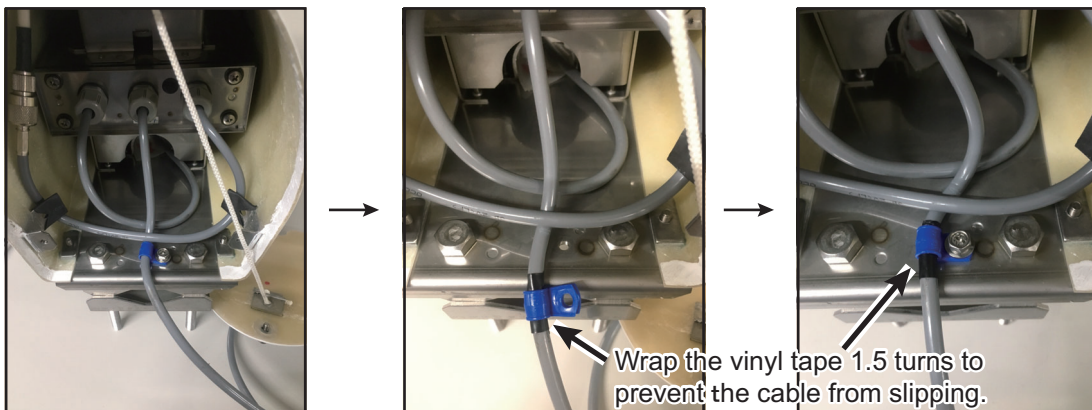

Installation overview of GPS/VHF combined antenna

Note: Where the mast on which the antenna is installed has a diameter of 60 mm to 80 mm, the optional mast installation kit is required (Model: OP24-5, Code: 005-954-510).

Installing the VHF antenna CX4-3/FEC or FAB-151D to the combined antenna GVA-100-T

The compatibility of VHF antenna (CX4-3/FEC or FAB-151D) with the GVA-100-T differs with GVA-100-T's serial number.

Compatibility of CX4-3/FEC, FAB-151D and GVA-100-T

Serial No.	FAB-151D	CX4-3/FEC
000101 to 019999	OK	NG
020000 and after	OK	OK

To install the VHF antenna CX4-3/FEC or FAB-151D to the combined antenna GVA-100-T (with serial number 020000 and after), follow the below procedures.

1. Unfasten the upset head bolts (M3, 4pcs.) at the back side of the GVA-100-T.

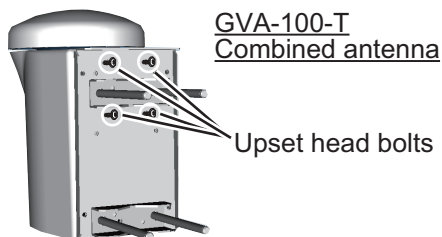

2. Turn the GVA-100-T upside-down, then unfasten three screws with captive washers (M3, 3pcs.) on the bottom cover to detach it.

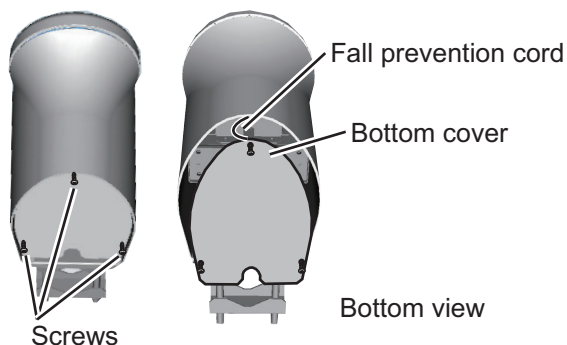

3. Remove the cushioning material from the connector of the cable to connect with VHF antenna CX4-3/FEC (MP-3D-360).

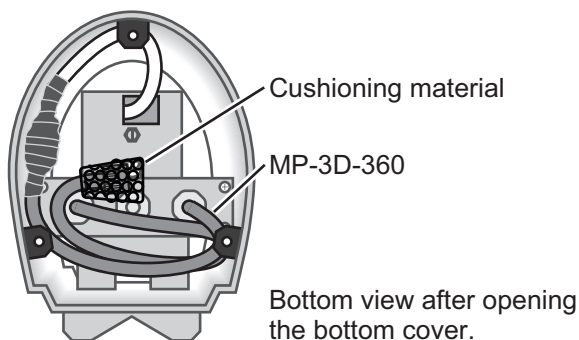

4. Insert the CX4-3/FEC to the GVA-100-T from the connector side.

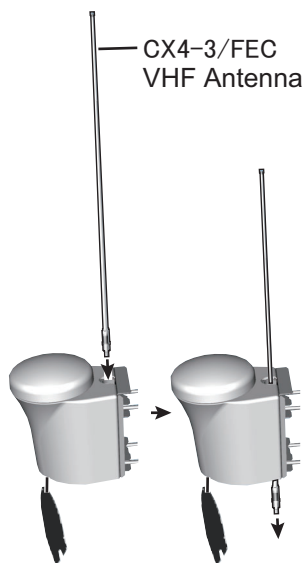

1. MOUNTING

5. Connect the MP-3D-360 connector to the CX4-3/FEC and wrap the junction of the connectors with self-vulcanizing tape and vinyl tape. Apply adhesive to the connectors.

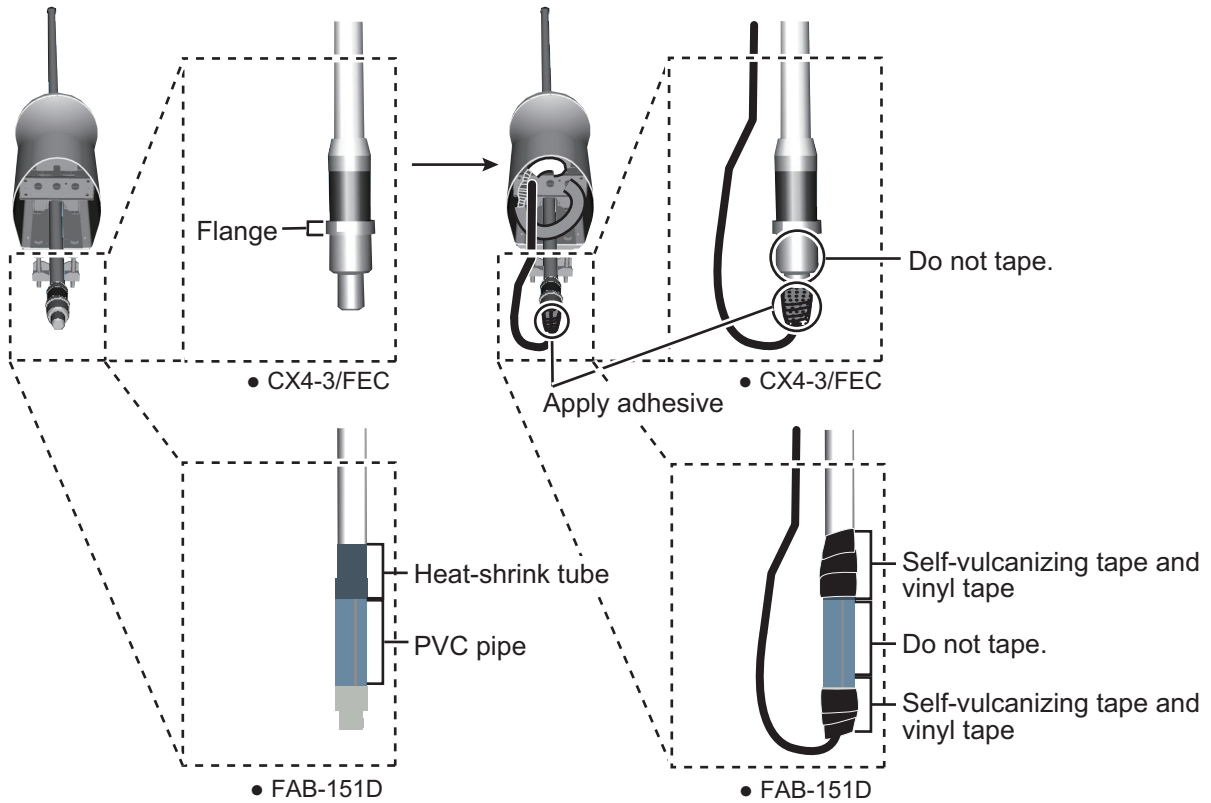

6. Raise the CX4-3/FEC or FAB-151D upward, confirm that the flange fits the caulking and tighten with the upset head bolts unfastened with step 1.

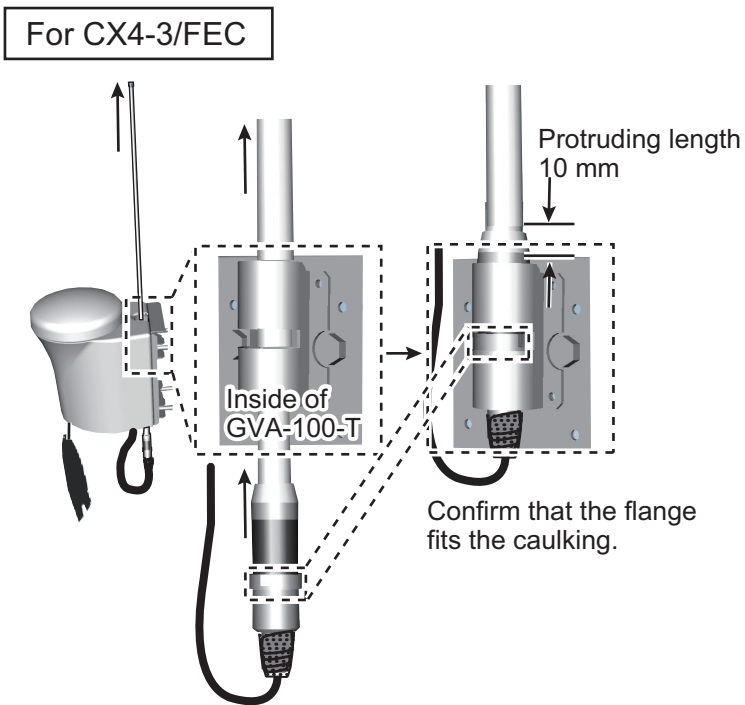

For FAB-151D

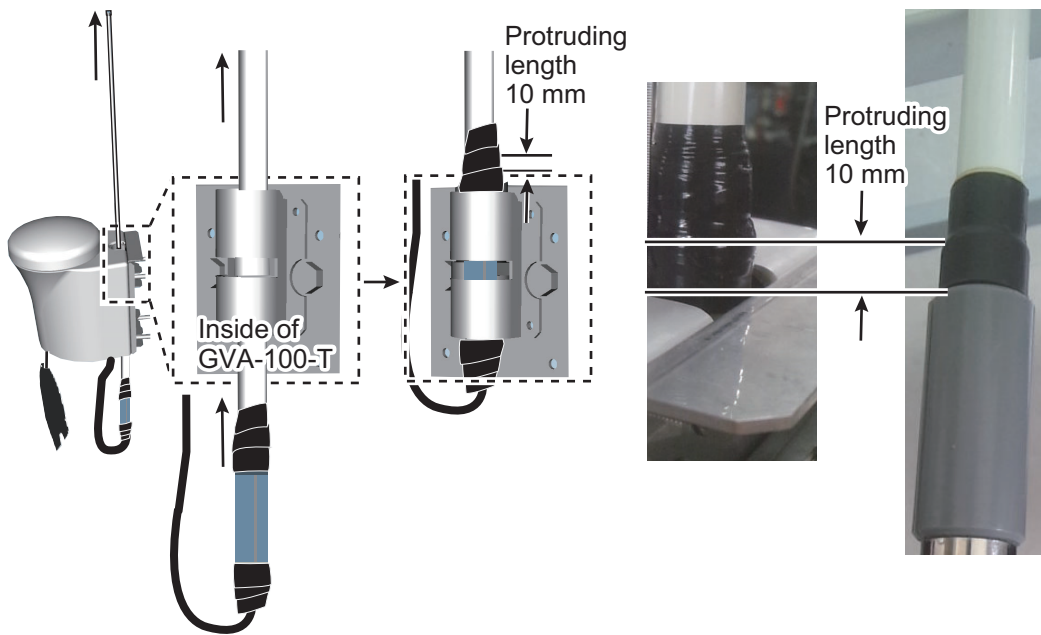

Correct installation



NG: PVC pipe can be seen.



NG: Taped part can not be seen.

7. Fasten the bottom cover to the GVA-100-T.



1. MOUNTING

Mounting procedure

1. Dismount the bottom cover, cut the cable-tie inside the unit and take out the coaxial connector attached to the combined box.
2. Loosen four screws to loosen whip antenna fixture and pull out the coaxial connector coming from the combined box through the hole in the whip antenna fixture.
3. Connect the coaxial connector to the whip antenna base and wrap the junction part of the whip antenna with vulcanizing tape and then vinyl tape for waterproofing.
4. Insert the whip antenna from the top of the combined antenna.
5. Secure the whip antenna with whip antenna fixture.
6. Using a new plastic band (supplied), secure the cables and coaxial connector inside the antenna case.
7. Mount the bottom cover.
8. Fix the GPS/VHF combined antenna to the ship's stanchion (40 to 50 mm diameter) with antenna fixing brackets, flat washers and hex. nuts.

Note: Coat the exposed parts of bolts and nuts with silicon sealant.

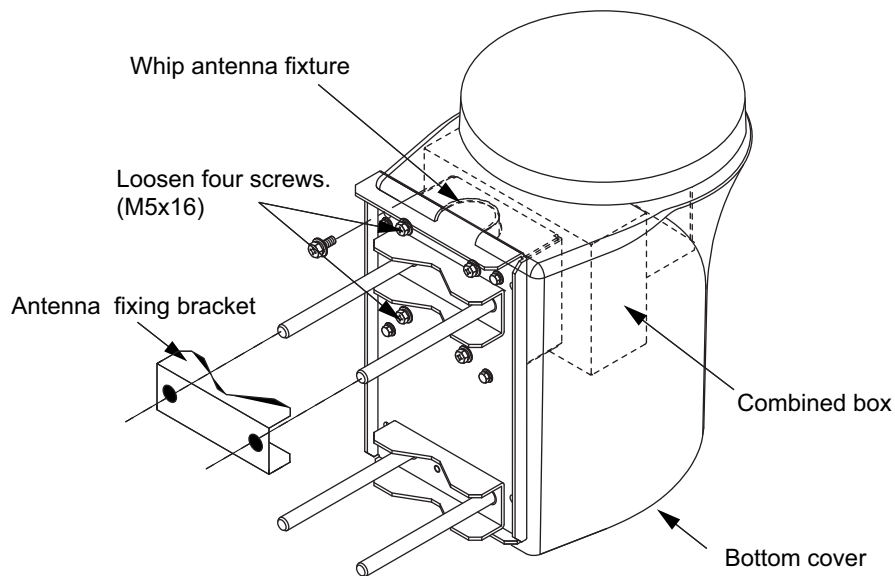

GPS/VHF Combined antenna

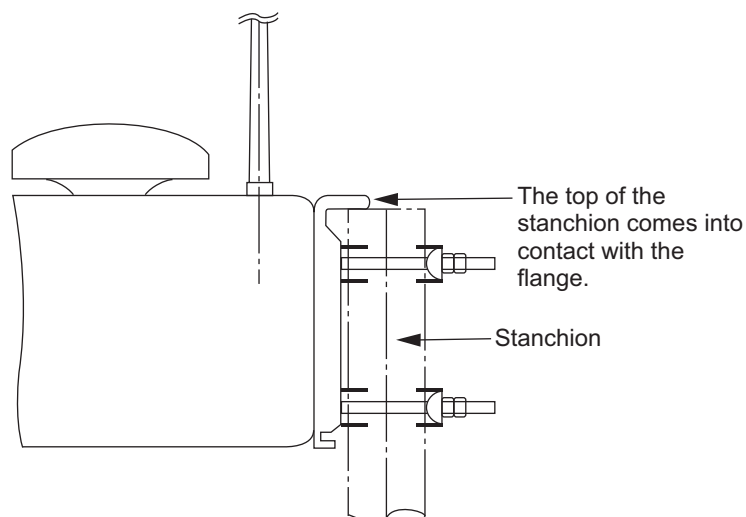

How to install distributor unit DB-1

The length of the cable between the distributor unit and transponder unit is 1 m so locate the distributor unit within 1 m from the transponder unit. Fix the distributor unit on the bulkhead, facing the cable entrance downward. Remove the lid of the distributor unit and secure the unit with two self-tapping screws.

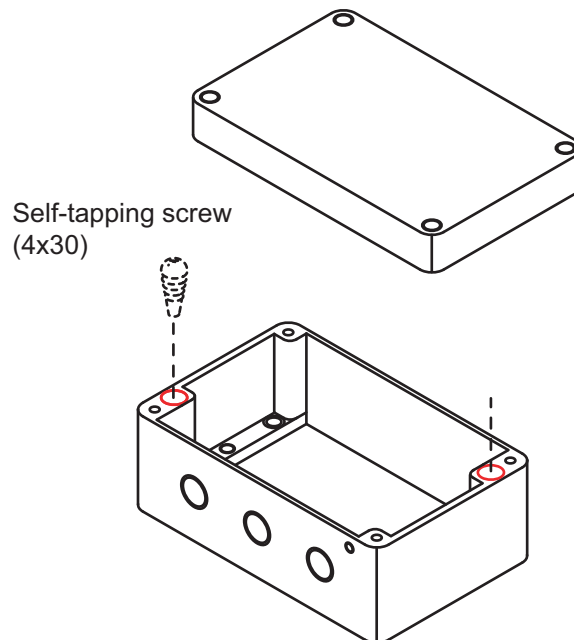

Note: Be sure no foreign material or water enters the distributor unit.

1.2 Monitor Unit

The monitor unit can be installed on a desktop or flush mounted in a panel. Install it on the chart table or near the steering place, referring to the outline drawing.

When selecting a mounting location for the monitor unit, keep the following in mind:

- Keep the unit out of direct sunlight.
- The temperature and humidity should be moderate and stable. (Operating temperature range: -15°C to $+55^{\circ}\text{C}$)
- Locate the unit away from exhaust pipes and vents.
- The mounting location should be well ventilated.
- Mount the unit where shock and vibration are minimal.
- Keep the unit away from electromagnetic field generating equipment such as motor, generator.
- For maintenance and checking purposes, leave sufficient space at the sides and rear of the unit and leave slack in cables. Refer to the outline drawing.
- A magnetic compass will be affected if the unit is placed too close to it. Observe the following compass safe distances to prevent disturbance to the magnetic compass:
 - Standard compass: 0.45 meters
 - Steering compass: 0.3 meters
- **For the flush mount**, make sure the mounting location is flat.

1. MOUNTING

Desktop mounting

1. Fasten the hanger with four self-tapping screws (5×20).
2. Fasten the monitor unit to the hanger with two knobs.

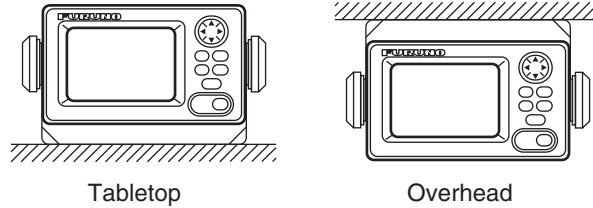

Flush mounting

There are two types of flush mount kits, F type and S type. For details, see the outline diagrams at the back of this manual.

F type

Use the optional flush mount kit OP20-29.

Name	Type	Code No.	Qty
Cosmetic panel	20-016-1051	100-251-370-10	1
Self-tapping screw	5×20	000-162-609-10	4
Hexagon-head bolt	M6×12	000-162-897-10	2
Spring washer	M6	000-158-855-10	2

1. Prepare a cutout in the mounting location whose dimensions are 183 (W) x 92 (H) mm.
2. Attach the cosmetic panel (20-016-1051) to the unit with two hex head bolts (M6×12) and two spring washers (M6).
3. Fix the unit to the mounting location with four self-tapping screws (5×20).

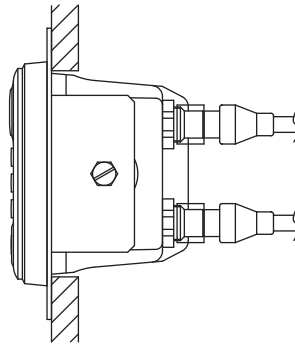

S type

Use the optional flush mount kit OP20-17.

Name	Type	Code No.	Qty
Fixing plate	20-007-2401	100-183-190-10	2
Hexagon-head bolt	M6×12	000-162-897-10	2
Wing bolt	M4×30	000-168-243-10	4
Wing nut	M4	000-168-239-10	4
Spring washer	M6	000-158-855-10	2

1. Prepare a cutout in the mounting location whose dimensions are 167 (W) x 92 (H) mm.

2. Insert the unit to the cutout.
3. Attach two fixing plates (20-007-2401) to the unit with two hex bolts (M6x12) and two spring washers (M6).
4. Screw four wing bolts (M4x30) to wing nuts (M4).
5. Fasten the unit with four wing bolts and nuts.

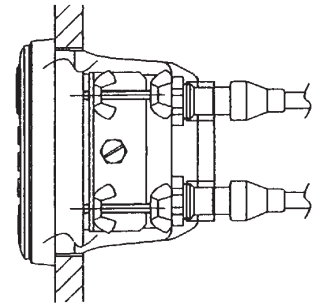

1.3 UAIS Transponder

Mount the transponder, where it is protected from rain and water splash. This unit can be installed on a bulkhead. Install it, referring to the outline drawing.

When selecting a mounting location for the transponder, keep the following in mind:

- Keep the transponder out of direct sunlight.
- The temperature and humidity should be moderate and stable. (Operating temperature range: -15°C to $+55^{\circ}\text{C}$)
- Locate the unit away from exhaust pipes and vents.
- The mounting location should be well ventilated.
- Mount the unit where shock and vibration are minimal.
- Keep the unit away from electromagnetic field generating equipment such as motor, generator.
- For maintenance and checking purposes, leave sufficient space at the sides and rear of the unit and leave slack in cables. Refer to the outline drawing.
- A magnetic compass will be affected if the unit is placed too close to it. Observe the following compass safe distances to prevent disturbance to the magnetic compass:

Standard compass: 1.2 meters

Steering compass: 0.8 meters

Mounting

Fix the unit with four self-tapping screws.

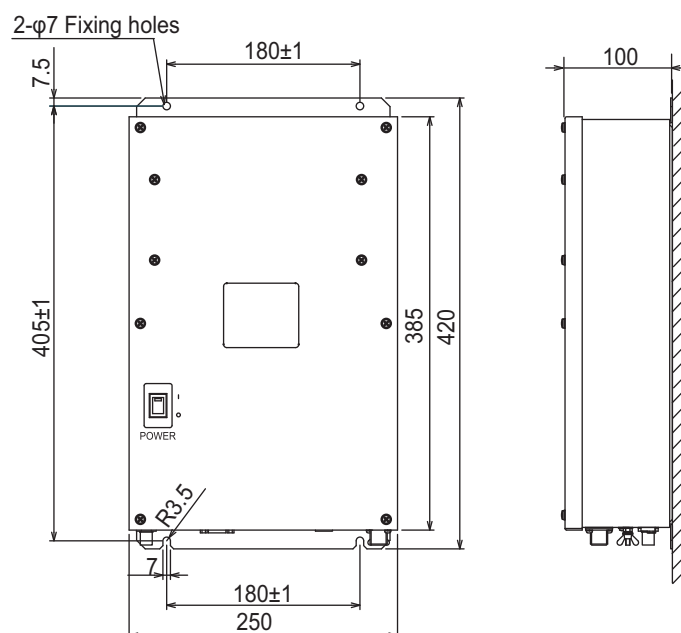

1.4 Power Supply (option)

When selecting a mounting location for the unit, keep the following in mind:

- Keep the unit out away from areas subject to water splash.
- Locate the unit away from exhaust pipes and vents.
- The mounting location should be well ventilated.
- Mount the unit where shock and vibration are minimal.
- A magnetic compass will be affected if the unit is placed too close to it. Observe the following compass safe distances to prevent disturbance to the magnetic compass:

Standard compass: 0.6 meters

Steering compass: 0.9 meters

Fix the unit with four self-tapping screws (4x16) to a desktop or the deck as shown in the figure below. It is not necessary to open the cover.

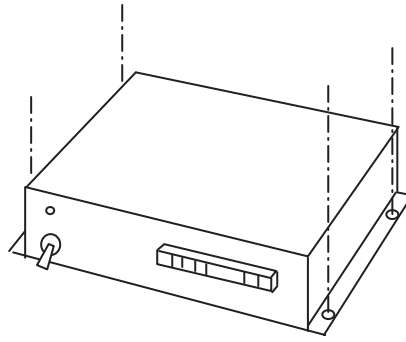

1.5 Pilot Plug (option)

The pilot plug should be mounted near where the pilot steers the ship. This plug is used to connect a PC to display AIS information for use by the pilot. Refer to the out-line drawing at the back of this manual for mounting dimensions.

2. WIRING

2.1 Connection

Connect the equipment, referring to the interconnection diagram at the back this manual.

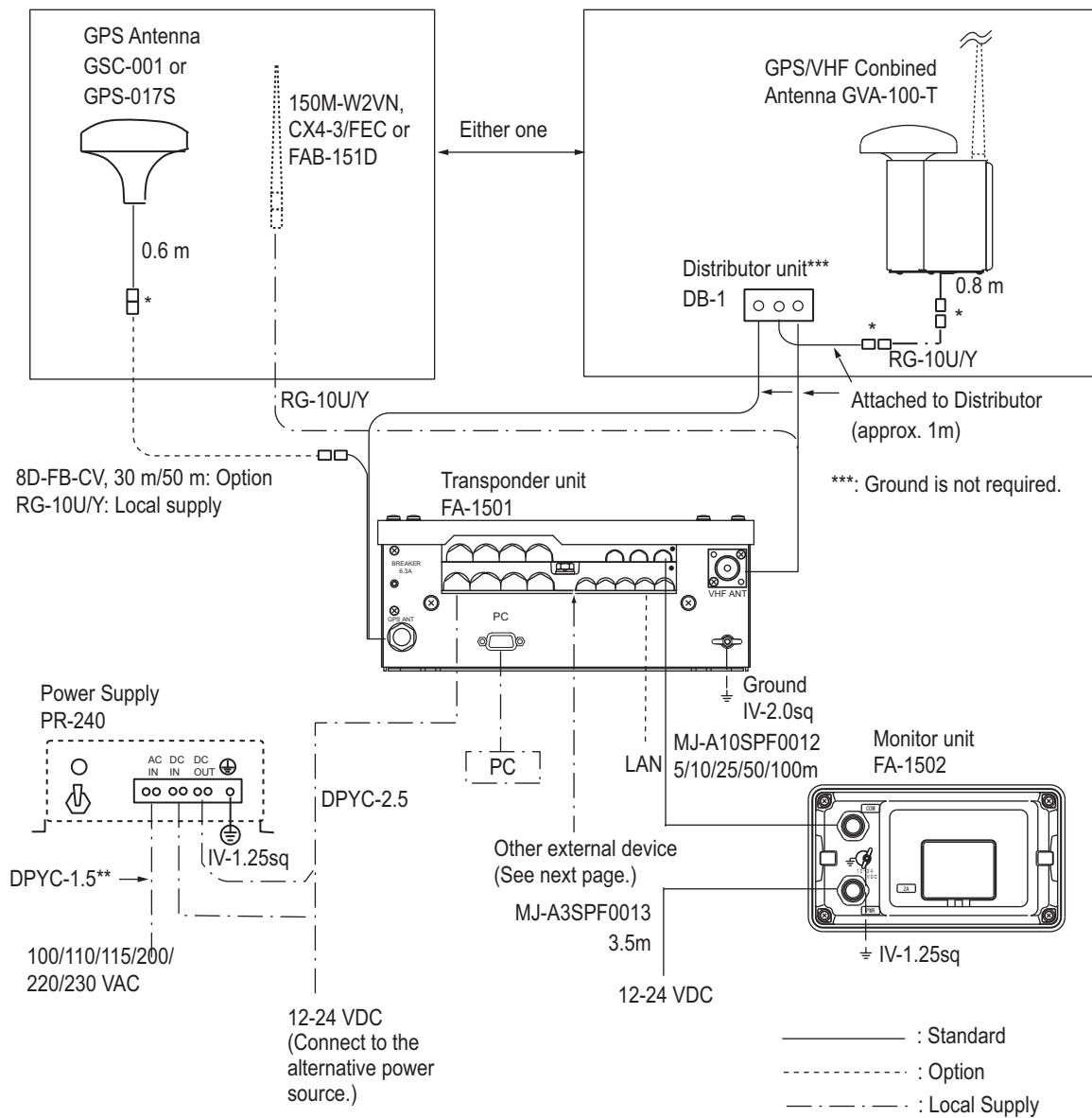

*, **: See page 2-2.

2. WIRING

COM1:	Long range communication device (Inmarsat C, etc.) or External display (Radar, ECDIS, Pilotplug)
COM2 & COM3:	External display, NAVNET 2, Pilot plug
COM4- COM6:	GPS, Gyrocompass, Speed log, ROT, etc.
Blue Sign:	Connects a Blue Sign device, a lighting device mounted on the bridge which gives off a blue light to warn oncoming vessels when your vessel is navigating a channel in the reverse direction.

Note: A plastic sheet is placed across the cable glands of the transponder to keep out foreign material. Cut out holes in the plastic where cables are to be lead in.

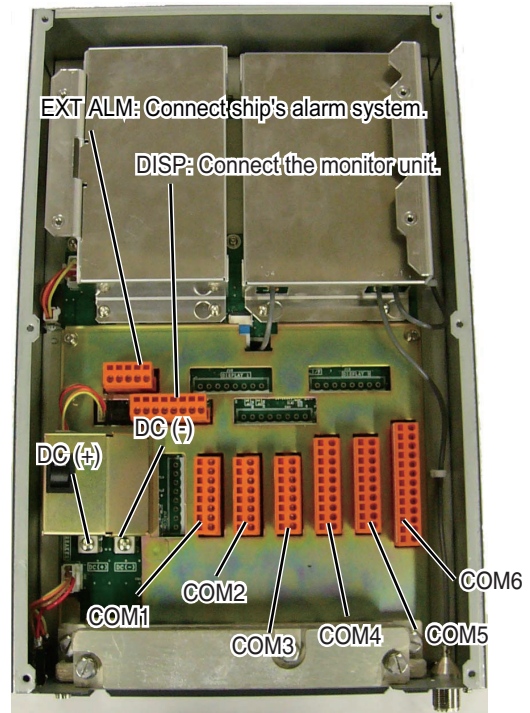

*: Waterproofing connectors

Wrap connector with vulcanizing tape and then vinyl tape. Bind the tape end with a cable-tie.

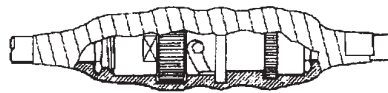

Waterproofing connector

** : DPYC-2.5, TTYCS-1Q and TTYCS-4 are Japan Industry Standard cables. Use them or the equivalents, referring to the Appendix.

2.1.1 Cable connection at transponder

Fabrication of cables TTYCS-4, TTYCS-1Q and TTYCS-1

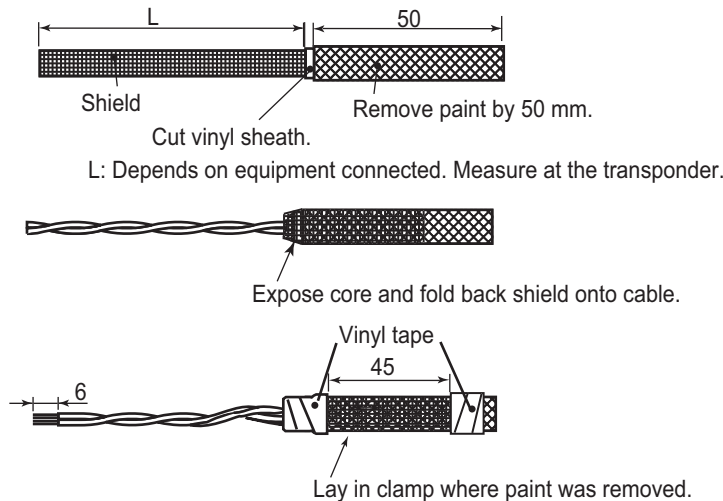

How to attach wires to the WAGO connector

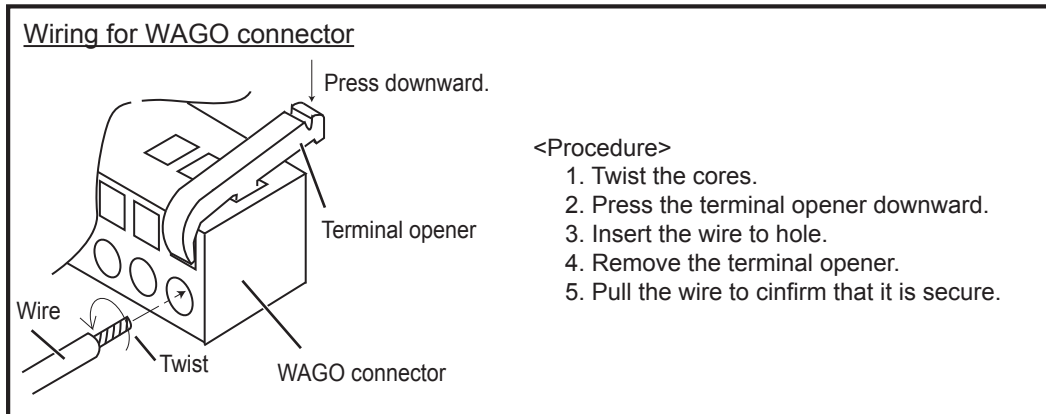

Fabrication of power cable DPYC-2.5

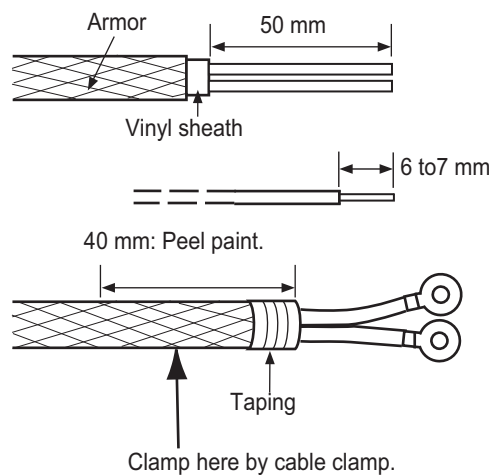

2.1.2 Terminating of COM1-6 port (For IEC 61162-2 signal)

When the signal is used IEC61162-2, the terminating is required as follows. The COM1-6 port does not set termination at factory setting.

Note: The incorrect setting of the termination may occur communication error.

COM1-6 port (RD: Listener, TD: Talker)	Termination
One-to-one connection between RD and TD	Jumper between terminal #7 and #8 of COM1-6 port.
No connection	Jumper between terminal #7 and #8 of COM1-6 port.
Single talker-Multi listener connection (FA-150 is one of the listeners.)	Set the termination on the equipment* connected with the longest cable among the listeners. *: When the FA-150 is equipment connected with the longest cable, jumper between terminal #7 and #8 of COM1-6 port. Note: Do not set the termination on the equipment other than the connected equipment with the longest cable.
Single talker-Multi listener connection (FA-150 is the talker.)	Set the termination on the equipment connected with the longest cable among the listeners. Note: Do not set the termination on the equipment other than the connected equipment with the longest cable.

2.2 Changing Ship's Mains Specifications

The AC-DC power supply PR-240 is shipped ready for connection to a 200-230 VAC ship's mains. If the ship's mains is 100 VAC-115 VAC, change the tap connection and terminal board connection as below. Attach label supplied as accessories to the front panel according to the ship's mains.

Ship's mains	Tap connection	Terminal board	Label
AC200-230V	SEL 230 V	Below (a)	200-230 VAC 2.5-2.0 A 1 ϕ 50/60 Hz
AC100-115V	SEL 115 V	Below (b)	100-115 VAC 4.0-3.5 A 1 ϕ 50/60 Hz

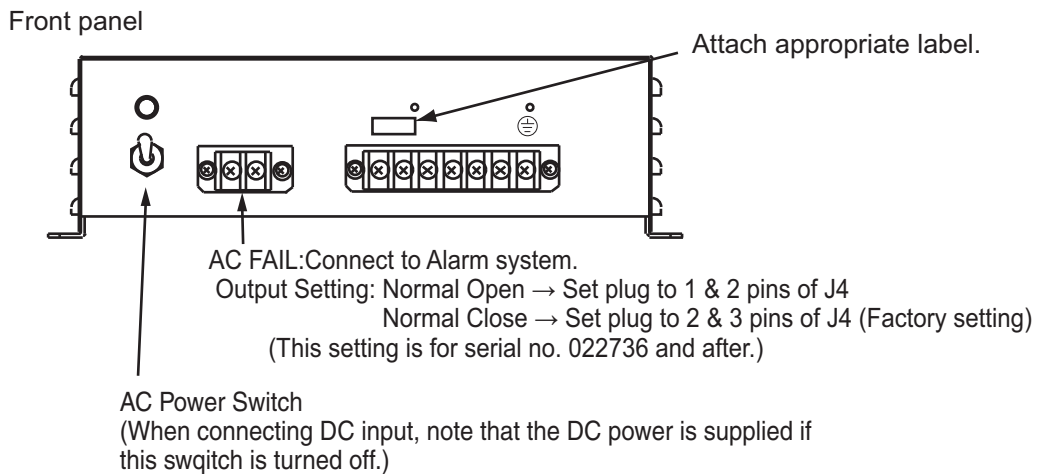
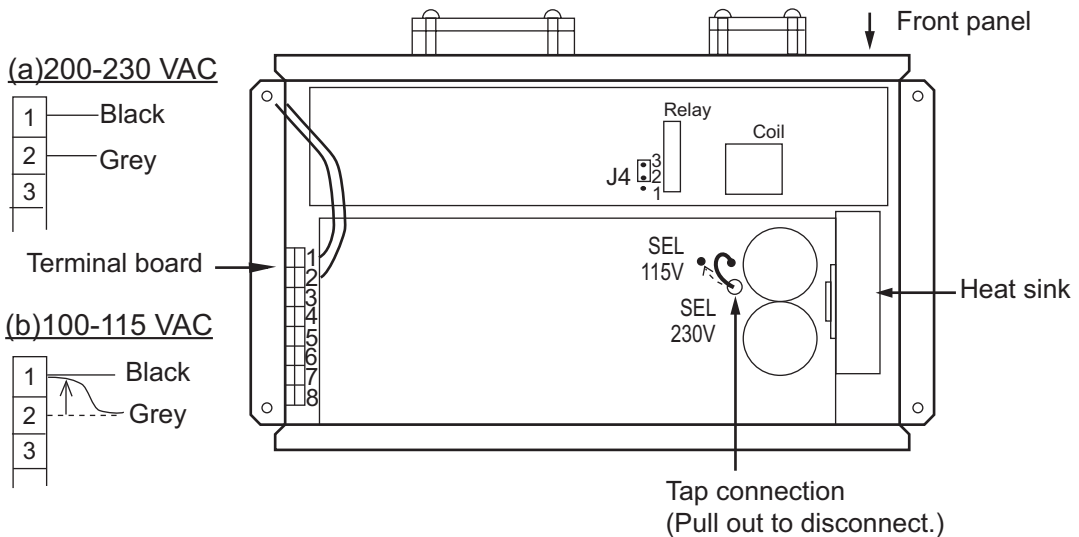
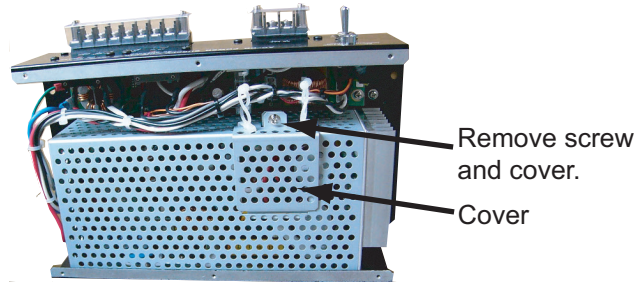

Note: The DC output load must be less than 8A.

3. SETTING AND ADJUSTMENT

After installing the equipment, set up the own ship's static information (MMSI, IMO number, ship's name, call sign, type of ship and GPS antenna position). Also, set up the I/O ports.

3.1 Inland AIS Specific Settings

This section shows how to activate and set up the Inland AIS feature. (If you do not require this feature, go to section 3.2.) The installer obtains the AIS activation key from the place of purchase.

Entering activation key

Enter your key number to activate the Inland AIS.

1. Press the **MENU** key to open the menu.

```
[MENU]
MSG
SENSOR STATUS
INTERNAL GPS
USER SETTINGS
INITIAL SETTINGS
CHANNEL SETTINGS
DIAGNOSTICS
```

2. Select [DIAGNOSTICS] then press the **ENT** key.

```
[DIAGNOSTICS]
MONITOR TEST
TRANSPONDER TEST
PWR ON/OFF HISTORY
TX ON/OFF HISTORY
MEMORY CLEAR
ACTIVATE KEY
FOR SERVICE
```

3. Select [ACTIVATE KEY] then press the **ENT** key.

```
[ACTIVATE KEY]
DEVICE ID
  XX-XX-XX-XX-XX
KEY
  - - -

QUIT[MENU]
```

4. Press the **ENT** key, enter your activation key then press the **ENT** key.

If you entered the activation key correctly, the indication "ACTIVATED!" appears then the system is automatically restarted.

3. SETTING AND ADJUSTMENT

How to select AIS mode

The Inland AIS has two operating modes: Inland (inland waterways) and SOLAS (SOLAS compliant class A AIS transponder). Select INLAND AIS mode as follows:

1. Press the **NAV STATUS** key to open the [NAV STATUS] menu.

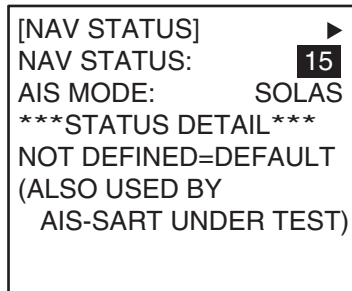

2. Push ▼ to select [AIS MODE] then press the **ENT** key.



3. Select [INLAND] (Inland AIS) then press the **ENT** key.

You are asked if you are sure to reboot the system. Press ◀ to select [YES] then press the **ENT** key to reboot.

How to set blue sign status

Blue sign (a day-sign), which in combination with a white flashing light, must be shown if you are sailing on the port-side shore (against traffic direction).

1. Press the **MENU** key to open the menu.

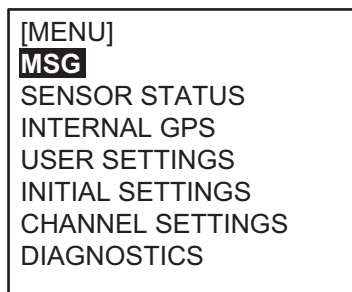

2. Press ▼ on the cursor pad to select [INITIAL SETTINGS] and press the **ENT** key. The password entry window appears.

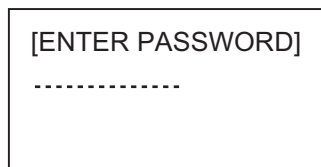

3. Enter the password to show the [INITIAL SETTINGS] menu. Note that the password is known by only the FURUNO dealer.

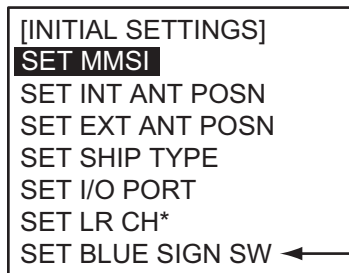

*: Availability depends on equipment specifications. Not shown unless so equipped.

← Appears for Inland AIS only

4. Select [SET BLUE SIGN SW] then press the **ENT** key.



5. [NOT AVAILABLE] is selected; press the **ENT** key.



6. Select [NOT AVAILABLE] (not in use) or [AVAILABLE] (in use) as applicable then press the **ENT** key.

3.2 How to Set MMSI, IMO No., Name and Call Sign

1. Display the [INITIAL SETTINGS] menu referring to step 1 to step 3 in "How to set blue sign status" on page 2.

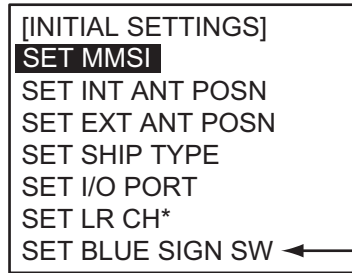

*: Availability depends on equipment specifications. Not shown unless so equipped.

← Appears for Inland AIS only

2. [SET MMSI] is selected; press the **ENT** key to display the [SET MMSI] window.

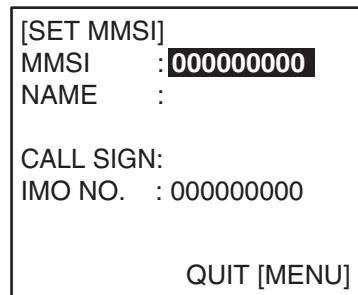

SET MMSI (Class A)

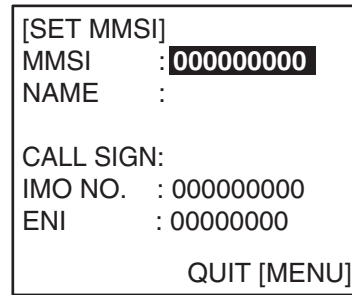

SET MMSI (Inland AIS)

3. [MMSI] is selected; press the **ENT** key. Use the cursor pad to set MMSI no., in nine digits, as follows:
 - 1) The cursor is selecting the 1st digit place of the MMSI no. Press ▲ or ▼ to select the 1st digit of the number. Pressing ▲ displays alphanumeric characters cyclically in order of blank space, alphabet, numerals and symbols.
 - 2) Press ► to shift the cursor to the adjacent place, then use ▲ or ▼ to select the 2nd digit.
 - 3) Repeat step 1) and step 2) to finish entering the number. To erase a character, insert a space.
 - 4) After entering all digits, press the **ENT** key to register input.
4. Enter IMO number, name of your vessel and call sign, similar to how you entered MMSI. For the Inland AIS, additionally enter ENI no.

IMO: Nine digits. If the IMO number has 7 digits, enter "0" twice followed by IMO number. If the ship has no IMO number, enter nine zeros.

ENI: Eight digits
5. After entering data, press the **MENU** key to close the menu.

Note: If you enter incorrect data, do the procedure from step 1.

3.3 How to Set GPS Antenna Position

1. Display the [INITIAL SETTINGS] menu referring to step 1 to step 3 in "How to set blue sign status" on page 3-2.
2. Press ▲ or ▼ key to choose [SET INT ANT POSN] and press the **ENT** key.

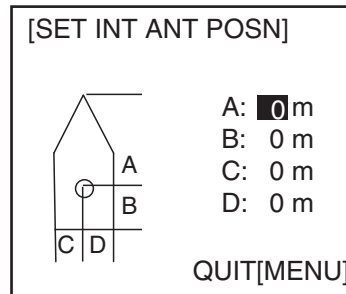

3. Press the **ENT** key again.
4. Use the cursor pad to enter the distance for "A" of the FA-150 GPS antenna then press the **ENT** key.
 - A: Distance from bow to GPS antenna position, setting range: 0-511 m
5. Press the **ENT** key and enter distance for B, C and D, similar to how you did for "A" in step 4.
 - B: Distance from stern to GPS antenna position, setting range: 0-511 m
 - C: Distance from port to GPS antenna position, setting range: 0-63 m
 - D: Distance from starboard to GPS antenna position, the setting range: 0-63 m
6. Press the **MENU** key to return to the [INITIAL SETTINGS] menu.
7. Press ▲ or ▼ key to choose [SET EXT ANT POSN] and press the **ENT** key.
8. Enter distance for location of an external GPS antenna (if connected) similar to how you did for the internal GPS antenna.
9. Finally press the **MENU** key to save the settings.

Notes

- Use "Length Over All" (not "Length Between Perpendicular") to express the dimensions for A and B.
- The sum of A+B (Length Over All) must be the same for both [INT ANT POSN] and [EXT ANT POSN].
- The sum of C+D (Width) must be the same for both INT [ANT POSN] and [EXT ANT POSN].

3.4 How to Set Ship Type

1. In the [INITIAL SETTINGS] window, press the ▲ or ▼ key to choose the [SET SHIP TYPE] and press the ENT key.

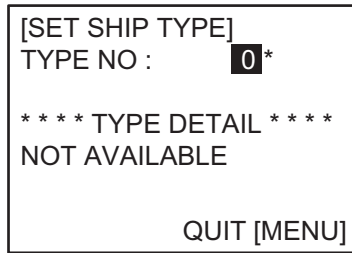

2. Press the [ENT] key and set number for ship type by using ▲ or ▼ key then press the [ENT] key, referring to the table below. For details, see “Section 1.5 Setting Up for Voyage” on the operator’s manual.

Ship type

No.	Ship type
1	Future use
2	WIG (Wing in ground)
3	Vessel
4	HSC (High speed craft)
5	Special craft
6	Passenger ships
7	Cargo ships
8	Tanker
9	Other type of ship

3. Press the MENU key to save the setting.

3.5 How to Set I/O Port

How to set COM port/PC port

1. In the [INITIAL SETTINGS] window, press ▲ or ▼ key to choose [SET I/O PORT] and press the ENT key.

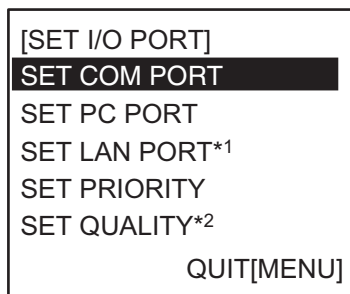

*1 Shown if fitted with LAN kit (option).

*2 Shown if Inland AIS is incorporated.

2. [SET COM PORT] is selected; press the ENT key.
3. Select an appropriate port among COM1, COM2, COM3, COM4, COM5 and COM6.

4. Press the **ENT** key to display the COM1 setting window.

```
[SET COM1]
MODE : LONG RANGE
SPEED: IEC 61162-2

QUIT [MENU]
```

5. Press the **ENT** key again to display the [MODE] setting window.

```
[SET COM1]
MODE : LONG RANGE
SPEED: LONG RANGE
EXT DISPLAY
DISABLE

QUIT [MENU]
```

6. Press **▲** or **▼** to choose the device connected and press the **ENT** key.
 [LONG RANGE]: Long range communication device, for ex. Inmarsat C.
 [EXT DISPLAY]: External display, for ex. Radar, ECDIS, Pilotplug, etc.
 [DISABLE]: When the port is not used.
7. Press the **ENT** key to display the [SPEED] setting window.

```
[SET COM1]
MODE : LONG RANGE
SPEED: IEC 61162-2
IEC 61162-1
IEC 61162-2

QUIT [MENU]
```

8. Press **▲** or **▼** to choose the data format, or data transmission rate.
 [IEC61162-1]: 4800 bps
 [IEC61162-2]: 38.4 Kbps
9. Press the **ENT** key.
10. Press the **MENU** key to save the settings.
11. Set up other ports similarly.
12. Set PC PORT similar to how you did for the COM PORT.

3. SETTING AND ADJUSTMENT

The table below shows the ports and corresponding items to be set.

Port and data format/data transmission rate

Port	External device (MODE)	Format/Rate (SPEED)
COM1	LONG RANGE	IEC61162-1, IEC61162-2
	EXT DISPLAY	IEC61162-1, IEC61162-2
	DISABLE	—
COM2	EXT DISPLAY	IEC61162-1, IEC61162-2
	MONITOR	IEC61162-1 (No use), IEC61162-2
	HI LEVEL IF	IEC61162-1 (No use), IEC61162-2
	DISABLE	—
COM3	EXT DISPLAY	IEC61162-1, IEC61162-2
	MONITOR	IEC61162-1 (No use), IEC61162-2
	HI LEVEL IF	IEC61162-1 (No use), IEC61162-2
	DISABLE	—
COM4	SENSOR	IEC61162-1, IEC61162-2
	EXT DISPLAY	IEC61162-2
	DISABLE	—
COM5	SENSOR	IEC61162-1, IEC61162-2
COM6	SENSOR	IEC61162-1 , IEC61162-2, AD-10
PC	STANDARD	4800bps, 9600bps 19.2kbps, 38.4kbps , 57.6kbps
	MONITOR	4800bps, 9600bps 19.2kbps, 38.4kbps , 57.6kbps
	SERVICE	4800bps, 9600bps 19.2kbps, 38.4kbps , 57.6kbps
	BEACON	4800bps
	DISABLE	—

Note: Bold shows default.

[LONG RANGE]: Long range communication device, for ex. Inmarsat C.

[EXT DISPLAY]: External display, for ex. Radar, ECDIS, Pilotplug, etc.

[SENSOR]: GPS, Gyrocompass, Speedlog, ROT, etc.

[HI LEVEL IF]: NAVNET 2

[STANDARD] (PC port): PC for inputting NMEA data (Same data as EXT DISPLAY).

[MONITOR] (PC port): PC having the FURUNO software FAISPC MK-2.

[SERVICE] (PC port): Service use FAISPC MK-2-equipped PC.

Priority setup

1. Press ▲ or ▼ to choose [SET PRIORITY] at the [SET I/O PORT] sub-menu and press the **ENT** key. The [PRIORITY] menu appears.

```
[SET PRIORITY]
[L/L, COG, SOG]
HDG
ROT

QUIT [MENU]
```

2. [L/L, COG, SOG] is selected; press the **ENT** key.

```
[SET L/L, COG, SOG]
COM4: 1
COM5: 2
COM6: 3

QUIT [MENU]
```

3. [COM4] is selected; press the **ENT** key to display the setting window.
4. Choose the priority level for the COM4 port (position, course over ground and speed over ground data) and press the **ENT** key. [1] is the highest and [3] is the lowest.
5. Set the priority of [COM5] and [COM6] similarly.

Note: Do not set same number among [COM4], [COM5] and [COM6].
6. Press the **MENU** key to return to the [SET PRIORITY] menu.
7. Press ▲ or ▼ to choose [HDG] and press the **ENT** key.
8. Set the priority for heading data similar to how you did for [L/L, COG, SOG].
9. Press ▲ or ▼ to choose [ROT] and press the **ENT** key.
10. Set the priority for rate-of-turn data similarly.
11. Press the **MENU** key several times to save the settings.

Quality setup (Inland AIS only)

If your speed, course or heading sensor is type approved, choose quality setting as shown below.

1. Press ▼ to choose [SET QUALITY] at the [SET I/O PORT] sub-menu then press the **ENT** key.

```
[SET QUALITY]
SPEED           : LOW
COURSE          : LOW
HEADING         : LOW

QUIT[MENU]
```

2. Press ▲ or ▼ to choose [SPEED], [COURSE] or [HEADING] then press the **ENT** key.
3. Choose [LOW] or [HIGH] (quality index) applicable then press the **ENT** key.
4. Press the **MENU** key several times to save the settings.

3.6 How to Set Long Range Channel

Set the channel to use to send your position to a satellite in an AIS message.

1. In the [INITIAL SETTINGS] window, press ▲ or ▼ key to choose the [SET LR CH] and press the **ENT** key.

```
[SET LR CH]
LONG RANGE CH
      FOR MSG 27
CH-C : 1075
CH-D : 1076

      QUIT [MENU]
```

2. Set the channel at [CH-C] then press the **ENT** key.
3. Set the channel at [CH-D] then press the **ENT** key.
4. Press the **MENU** key several times to save the settings.

Note: The availability of this function depends on equipment specifications. Not shown unless so equipped.

4. ATTACHING LAN KIT (OPTION)

To connect to PC network or NAVNET 3D network, the optional LAN kit is required.

LAN kit (Type: OP24-8. Code: 005-956-020)

	Name	Code no.	Qty	Remark
1	NET100 board	001-099-710	1	03P9332
2	Hex. spacer	000-159-292-10	4	

How to attach the LAN kit

1. Dismount the bottom cover.
2. Attach NET100 board 03P9332 to the 24P0035 board, referring to the figure shown below.

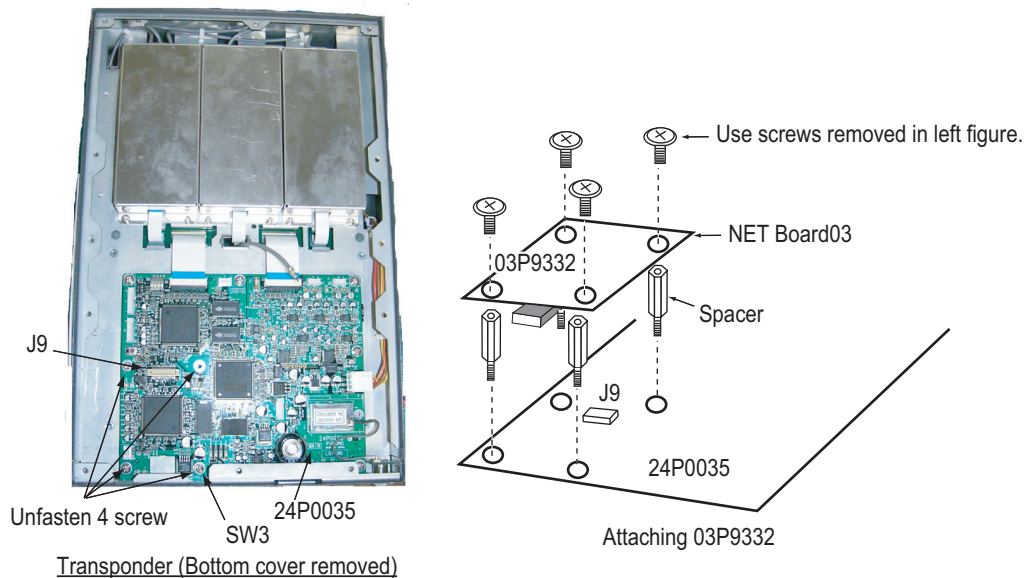

3. Set DIP switch SW3 #4 as follows.
 - For NAVNET 3D network: SW3 #4 OFF (default)
 - For PC network: SW3 #4 ON

How to set LAN port for PC network

1. Press the **MENU** key, choose [INITIAL SETTING], enter password, choose [SET I/O PORT] and press the **ENT** key to show the [SET I/O PORT] sub menu.
2. Press **▲** or **▼** to choose [SET LAN PORT] and press the **ENT** key. The window shown in the right appears.
3. Press the **ENT** key to show the mode selecting window.
4. Press **▲** or **▼** to choose suitable mode and press the **ENT** key.
 - [STANDARD]: When connecting a LAN device
 - [MONITOR]: When connecting a monitor
 - [SERVICE]: Data output for service man
 - [DISABLE]: No connection

```

[SET LAN PORT]
MODE : STANDARD
IP ADDRESS
172. 031. 024. 001
SUB NET MASK
255. 255. 000. 000
PORT NO. : 10000
QUIT [MENU]
  
```

4. ATTACHING LAN KIT (OPTION)

5. Press the **ENT** key, enter IP address in the IP ADDRESS field and press the **ENT** key. (Setting range: 000.000.000.000 to 255.255.255.255) Choose digit with ◀ or ▶; set value with ▲ or ▼.
6. Press the **ENT** key, enter sub net mask in the [SUB NET MASK] field and press the **ENT** key. (Setting range: 000.000.000.000 to 255.255.255.255)
7. Press the **ENT** key, enter port number in the [PORT NO.] field and press the **ENT** key. (Setting range: 0 to 65535)
8. Press the **MENU** key several times to save the settings and close the menu.

How to set LAN port for NAVNET 3D network

1. Press the **MENU** key, choose [INITIAL SETTING], enter password, choose [SET I/O PORT] and press the **ENT** key to show the [SET I/O PORT] sub menu.
2. Press ▲ or ▼ to choose [SET LAN PORT] and press the **ENT** key. The window shown in the right appears.
3. Press the **ENT** key, enter IP address in the [IP ADDRESS] field and press the **ENT** key. (Setting range: 000.000.000.000 to 255.255.255.255) Choose digit with ◀ or ▶; set value with ▲ or ▼.
4. Press the **ENT** key, enter sub net mask in the [SUB NET MASK] field and press the **ENT** key. (Setting range: 000.000.000.000 to 255.255.255.255)
5. Press the **ENT** key, enter port number in the [NAVNET PORT NO.] field and press the **ENT** key. (Setting range: 10000 to 30000)
6. Press ▼ to show next page. The window shown in the right appears.
7. Press the **ENT** key, enter gateway address in the [GATEWAY ADDRESS] field and press the **ENT** key. (Setting range: 000.000.000.000 to 255.255.255.255)
8. At the [HOST NAME] field, enter host name that is used in the NAVNET 3D (Setting range: AIS 0 to AIS 9).
9. At the [AIS OUTPUT] field, set output condition.
[AUTO]: Auto-detect of where to output AIS data.
[CONTINUOUS]: AIS Output AIS data continuously.
10. At the [GPS OUTPUT] field, set GPS data (L/L, SOF, COG) output condition between [AUTO] and [CONTINUOUS].
11. At the [ZDA OUTPUT] field, set time data output condition between [AUTO] and [CONTINUOUS].
12. Press the **MENU** key several times to save the settings and close the menu.

```
[SET LAN PORT]      1/2
IP ADDRESS
  172. 031. 024. 001
SUB NET MASK
  255. 255. 000. 000
NAVNET PORT NO.
  10000
```

```
[SET LAN PORT]      2/2
GATEWAY ADDRESS
  000. 000. 000. 000
HOST NAME : AIS0
AISOUTPUT  : CONTINUOUS
GPSOUTPUT  : AUTO
ZDAOUTPUT  : AUTO
```

5. IEC 61162-1/2 DATA SENTENCES

IEC 61162-1/2 format data is input or output from the data port COM1-COM6. The table below shows the input/output data specifications.

Transponder

Port	Menu setting	Input/Output	Data format
COM1	LONG RANGE	Input/Output*	IEC61162-2 (38.4kbps)/ IEC61162-1 (4800bps)
	EXT DISPLAY	Input/Output*	IEC61162-2 (38.4kbps)/ IEC61162-1 (4800bps)
COM2	EXT DISPLAY	Input/Output*	IEC61162-2 (38.4kbps)/ IEC61162-1 (4800bps)
COM3	EXT DISPLAY	Input/Output*	IEC61162-2 (38.4kbps)/ IEC61162-1 (4800bps)
COM4	SENSOR	Input*	IEC61162-2 (38.4kbps)/ IEC61162-1 (4800bps)
	EXT DISPLAY	Input/Output*	IEC61162-2 (38.4kbps)
COM5	SENSOR	Input*	IEC61162-2 (38.4kbps)/ IEC61162-1 (4800bps)
COM6	SENSOR	Input*	IEC61162-2 (38.4kbps)/ IEC61162-1 (4800bps) AD-10

*: See the table below.

Input data/Sentences

Sentence (Priority)	Contents
ABM	Addressed binary and safety related message
ACA	AIS regional channel assignment message
ACK	Acknowledge alarm
ACN	Alert command
AIR	AIS interrogation request
BBM	UAIS broadcast binary message
HBT	Heart beat supervision
VSD	UAIS voyage static data
LRI	Long Range interrogation
LRF	Long Range function
DTM	Datum reference
GNS>GLL>GGA>RMC	Position
VBW>RMC>VTG>OSD	Speed over ground
RMC>VTG>OSD	Course over ground
THS>HDT>OSD>AD-10 format	Heading
GBS	GNSS satellite fault detection
ROT> Calculated value	Rate of turn
SSD	UAIS ship static data

Output data/Sentences

Sentence (Priority)	Contents
AIABK	UAIS addressed and binary broadcast acknowledgment
AIACA	AIS regional channel assignment message
AIACS	Channel management information source
AIALC	Cyclic alert list
AIALF	Alert sentence
AIALR	Set alarm state
AIARC	Alert command refused
AIHBT	Heart beat supervision
AILRF, AILR1, AILR2, AILR3, AILRI	Long-range function Long-range reply with destination for function request "A" Long-range reply for function requests "B, C, E and F" Long-range reply for function requests "I, O, P, U and W" Long-range Interrogation
AISSD	UAIS ship static data
AITXT	Text transmission
AIVDM	VHF data-link message
AIVDO	UAIS VHF data-link own-vessel report
AIVER	Version
AIVSD	UAIS voyage static data

Inland AIS specific sentences

Sentence	Contents
< Input >	
PIWWIVD	Inland waterway voyage data
PIWWSPW	Inland AIS security password
PIWWSSD	Inland waterway static ship data
PIWWVSD	Inland waterway voyage data
< Output >	
PIWWSPR	Inland AIS security password response

APPENDIX 1 JIS CABLE GUIDE

Cables listed in the manual are usually shown as Japanese Industrial Standard (JIS). Use the following guide to locate an equivalent cable locally.

JIS cable names may have up to 6 alphabetical characters, followed by a dash and a numerical value (example: DPYC-2.5).

For core types D and T, the numerical designation indicates the *cross-sectional Area (mm²)* of the core wire(s) in the cable.

For core types M and TT, the numerical designation indicates the *number of core wires* in the cable.

1. Core Type

D: Double core power line

T: Triple core power line

M: Multi core

TT: Twisted pair communications
(1Q=quad cable)

2. Insulation Type

P: Ethylene Propylene

Rubber

3. Sheath Type

Y: PVC (Vinyl)

4. Armor Type

C: Steel

5. Sheath Type

Y: Anticorrosive vinyl sheath

6. Shielding Type

S: All cores in one sheath

-S: Individually sheathed cores

SLA: All cores in one shield, plastic tape w/aluminum tape

-SLA: Individually shielded cores, plastic tape w/aluminum tape



DPYCY



TPYCY

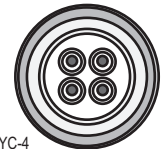

MPYC-4

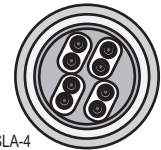

TTYCSLA-4

1 2 3 4 5 6
EX: TTYCYSLA - 4
 Designation type | # of twisted pairs

1 2 3 4
MPYC - 4
 Designation type | # of cores

The following reference table lists gives the measurements of JIS cables commonly used with Furuno products:

Type	Core Area	Core Diameter	Cable Diameter	Type	Core Area	Core Diameter	Cable Diameter
DPYC-1.5	1.5mm ²	1.56mm	11.7mm	TTYCS-1	0.75mm ²	1.11mm	10.1mm
DPYC-2.5	2.5mm ²	2.01mm	12.8mm	TTYCS-1T	0.75mm ²	1.11mm	10.6mm
DPYC-4	4.0mm ²	2.55mm	13.9mm	TTYCS-1Q	0.75mm ²	1.11mm	11.3mm
DPYC-6	6.0mm ²	3.12mm	15.2mm	TTYCS-4	0.75mm ²	1.11mm	16.3mm
DPYC-10	10.0mm ²	4.05mm	17.1mm	TTYCSLA-1	0.75mm ²	1.11mm	9.4mm
DPYCY-1.5	1.5mm ²	1.56mm	13.7mm	TTYCSLA-1T	0.75mm ²	1.11mm	10.1mm
DPYCY-2.5	2.5mm ²	2.01mm	14.8mm	TTYCSLA-1Q	0.75mm ²	1.11mm	10.8mm
DPYCY-4	4.0mm ²	2.55mm	15.9mm	TTYCSLA-4	0.75mm ²	1.11mm	15.7mm
MPYC-2	1.0mm ²	1.29mm	10.0mm	TTYCY-1	0.75mm ²	1.11mm	11.0mm
MPYC-4	1.0mm ²	1.29mm	11.2mm	TTYCY-1T	0.75mm ²	1.11mm	11.7mm
MPYC-7	1.0mm ²	1.29mm	13.2mm	TTYCY-1Q	0.75mm ²	1.11mm	12.6mm
MPYC-12	1.0mm ²	1.29mm	16.8mm	TTYCY-4	0.75mm ²	1.11mm	17.7mm
TPYC-1.5	1.5mm ²	1.56mm	12.5mm	TTYCY-4S	0.75mm ²	1.11mm	21.1mm
TPYC-2.5	2.5mm ²	2.01mm	13.5mm	TTYCY-4SLA	0.75mm ²	1.11mm	19.5mm
TPYC-4	4.0mm ²	2.55mm	14.7mm	TTYCYS-1	0.75mm ²	1.11mm	12.1mm
TPYCY-1.5	1.5mm ²	1.56mm	14.5mm	TTYCYS-4	0.75mm ²	1.11mm	18.5mm
TPYCY-2.5	2.5mm ²	2.01mm	15.5mm	TTYCYSLA-1	0.75mm ²	1.11mm	11.2mm
TPYCY-4	4.0mm ²	2.55mm	16.9mm	TTYCYSLA-4	0.75mm ²	1.11mm	17.9mm

PACKING LIST

GVA-100 (GVA用)

24AA-X-9855 -2 1/1

A-1

NAME	OUTLINE	DESCRIPTION/CODE No.	QTY
ユニット			
複合空中線部		GVA-100	1
GPS/VHF COMBINED ANTENNA		000-053-810-00	
分配器		DB-1	1
DISTRIBUTER UNIT		000-053-854-00	
工事材料			
CP24-00141			
アンテナ取付金具		24-003-3015-0	2
ANTENNA FIXING BRACKET		100-302-670-00	
コネクタ (N)		N-P-8DFB	2
CONNECTOR		000-140-463-00	
コネクター		CV-200HT	2
PLASTIC BAND		000-162-191-10	
ミカ平座金		MB SUS304	4
FLAT WASHER		000-864-130-00	
六角ナット 1種		MB SUS304	8
HEX NUT		000-863-110-00	

型式/コード番号が2段の場合、下段より上段に代わる過渡期品であり、どちらが入っています。なお、品質は変わりません。
TWO TYPES AND CODES MAY BE LISTED FOR AN ITEM. THE LOWER PRODUCT MAY BE SHIPPED IN PLACE OF THE UPPER PRODUCT. QUALITY IS THE SAME.
(略図の寸法は、参考値です。DIMENSIONS IN DRAWING FOR REFERENCE ONLY.)

C4417-705-B

A-2

FURUNO

CODE NO.	005-955-560-00	24AC-X-9403-5			
TYPE	CP24-00502				
工事材料表					
INSTALLATION MATERIALS					
番号	名称	略図	型名/規格	数量	用途/備考
1	変換ケーブル組品 ADAPTOR CABLE ASSEMBLY		NU-TP-3DXV-1 CODE NO. 000-248-160-30	1	
2	コネクタ (N) CONNECTOR		N-P-8DSFA CODE NO. 000-167-921-10	2	
3	コネクタ (TNC-N) COAXIAL CONNECTOR ADAPTOR		TNCP-NJ CODE NO. 000-166-599-10	1	
4	絶縁テープ INSULATION TAPE		UF-7 0.5X19X5M CODE NO. 000-165-833-10	1	
5	ビニールテープ VINYL TAPE		V36X601 CODE NO. 000-177-579-10	1	



型式/コード番号が2段の場合、下段より上段に代わる過渡期品であり、どちらが入っています。なお、品質は変わりません。
TWO TYPES AND CODES MAY BE LISTED FOR AN ITEM. THE LOWER PRODUCT MAY BE SHIPPED IN PLACE OF THE UPPER PRODUCT. QUALITY IS THE SAME.
(略図の寸法は、参考値です。DIMENSIONS IN DRAWING FOR REFERENCE ONLY.)

FURUNO ELECTRIC CO., LTD.

C4431-M02-F

FURUNO

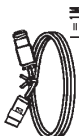
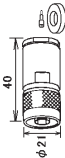
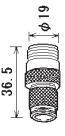
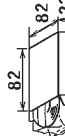
CODE NO.	004-381-190-00	20AX-X-9401-9	1/1
TYPE	CP20-02701		



工事材料表 INSTALLATION MATERIALS			
番号 NO.	名称 NAME	略図 OUTLINE	用途/備考 REMARKS
1	変換ケーブル組品 ADAPTOR CABLE ASSEMBLY	 L=1M	数量 QTY 1
2	同軸コネクタ組品 COAXIAL CONNECTOR TYPE*		数量 QTY 1
3	同軸アダプタ組品 COAXIAL CONNECTOR ADAPTOR		数量 QTY 1
4	絶縁テープ INSULATION TAPE		数量 QTY 1
5	ビニールテープ VINYL TAPE		数量 QTY 1

(略図の寸法は、参考値です。 DIMENSIONS IN DRAWING FOR REFERENCE ONLY.)

FURUNO ELECTRIC CO., LTD.

FURUNO

CODE NO.	20AG-X-9404-4	1/1
TYPE		

明細書 DESCRIPTION			
番号 NO.	名称 NAME	略図 OUTLINE	用途/備考 REMARKS
1	アンテナケーブル組品 ANTENNA CABLE ASSY.	 L=30M	数量 QTY 1 選択 BE SELECTED TO
2	アンテナケーブル組品 ANTENNA CABLE ASSEMBLY	 L=40M	数量 QTY 1 選択 BE SELECTED TO
3	アンテナケーブル組品 ANTENNA CABLE ASSY.	 L=50M	数量 QTY 1 選択 BE SELECTED TO

型式/コード番号が2図の場合、下図より上図に代わる油断部品であり、どちらかが入っています。なお、品質は変わりません。
TWO TYPES AND CODES MAY BE LISTED FOR AN ITEM. THE LOWER PRODUCT MAY BE SHIPPED IN PLACE OF THE UPPER PRODUCT.
QUALITY IS THE SAME.
(略図の寸法は、参考値です。 DIMENSIONS IN DRAWING FOR REFERENCE ONLY.)



FURUNO ELECTRIC CO., LTD.

FURUNO

CODE NO.	005-955-570-00	244C-X-9401-3	1/1
TYPE	CP24-00301		

工事材料表

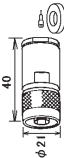
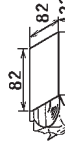
INSTALLATION MATERIALS

番号 NO.	名称 NAME	略図 OUTLINE	型名/規格 DESCRIPTIONS	数量 QTY	用途/備考 REMARKS
1	コネクタ(N) COAXIAL CONNECTOR *M TYPE*		U-F-80FB-1-CF CODE NO. 000-156-916-10	1	
2	絶縁テープ SELF-BONDING TAPE		U-F-7 0.5X19X5M CODE NO. 000-165-833-10 000-800-385-00	1	
3	ビニールテープ VINYL TAPE		V360K01 CODE NO. 000-177-579-10	1	

(略図の寸法は、参考値です。 DIMENSIONS IN DRAWING FOR REFERENCE ONLY.)

FURUNO ELECTRIC CO . . . LTD.

C4431-M03-D



FURUNO

CODE NO.	148N-X-9405-1
TYPE	

工事材料表

INSTALLATION MATERIALS

GP-3100/3050, GP-188/3100MARK-2, GP-3300

番号 NO.	名称 NAME	略図 OUTLINE	型名/規格 DESCRIPTIONS	数量 QTY	用途/備考 REMARKS
1	アンテナケーブル CABLE ASSY.		8D-FB-CY *50M* CODE NO. 000-117-589	1	選択 TO BE SELECTED
2	アンテナケーブル ANTENNA CABLE ASSY.		8D-FB-CY *30M* CODE NO. 000-111-547	1	選択 TO BE SELECTED

(略図の寸法は、参考値です。 DIMENSIONS IN DRAWING FOR REFERENCE ONLY.)

FURUNO ELECTRIC CO . . . LTD.

C4358-M02-B

表 1 TABLE 1

寸法区分 (mm) DIMENSION	公差 (mm) TOLERANCE
L ≤ 50	±1.5
50 < L ≤ 100	±2.5
100 < L ≤ 500	±3

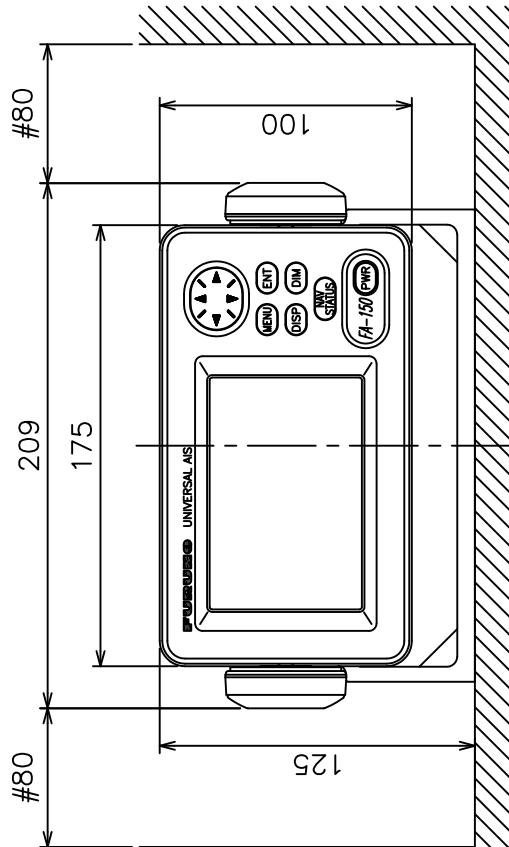
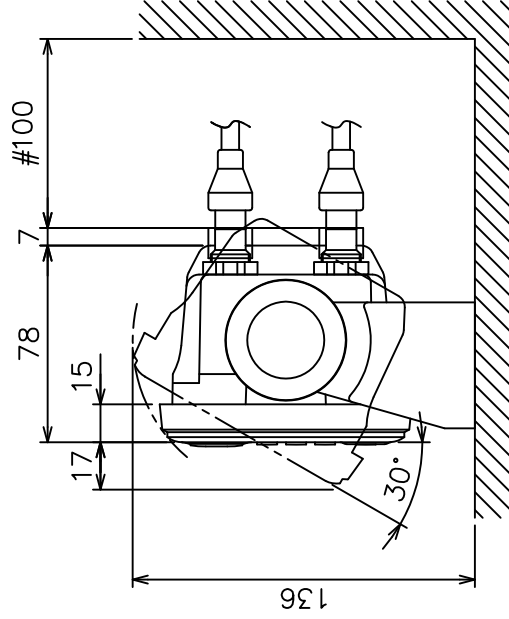
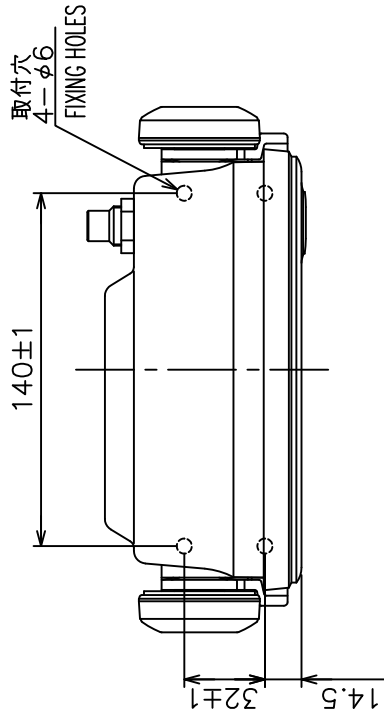
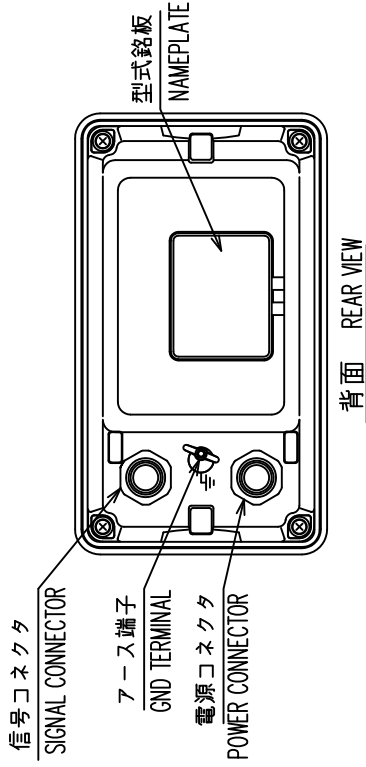

- 注記
- 1) 指定外寸法公差は表 1 による。
 - 2) #印寸法は最小サービスマン寸法とする。
 - 3) 取付用ネジはトラスタックピンネジ呼び径5×20を使用のこと。
 - 4) ケーブルはサービスマン時、本体を前方に十分に引き出せるよう余裕を持たせること。

- NOTE
1. TABLE 1 INDICATES TOLERANCE OF DIMENSIONS WHICH IS NOT SPECIFIED.
 2. # MINIMUM SERVICE CLEARANCE.
 3. USE TAPPING SCREWS φ5x20 FOR FIXING THE UNIT.
 4. LEAVE SUFFICIENT CABLE LENGTH SO THAT THE UNIT CAN BE DRAWN FOREWORD FOR MAINTENANCE.

DRAWN	14/Nov/2017	I. YAMASAKI	TITLE	FA-150Z
CHECKED	14/Nov/2017	H. MAKI	名称	表示部 (卓上装備)
APPROVED	15/Nov/2017	H. MAKI	外寸図	
SCALE	1/3	MASS ±10%	NAME	MONITOR UNIT (TABLETOP MOUNT)
DWG. No.	C4431-G01-D	kg	REF. No.	24-006-300G-2

表 1 TABLE 1

寸法区分 (mm) DIMENSION	公差 (mm) TOLERANCE
L ≤ 50	±1.5
50 < L ≤ 100	±2.5
100 < L ≤ 500	±3

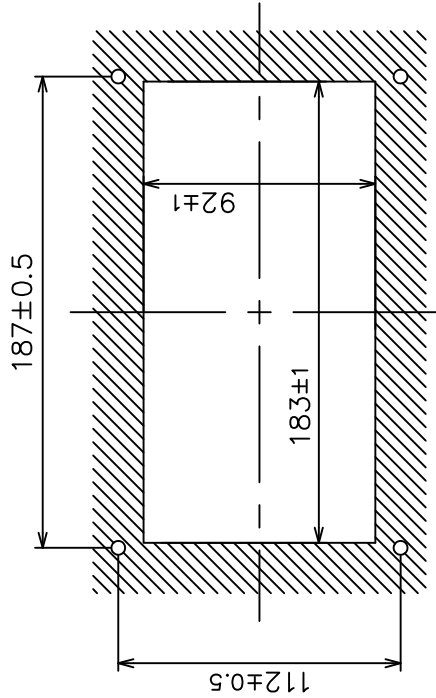
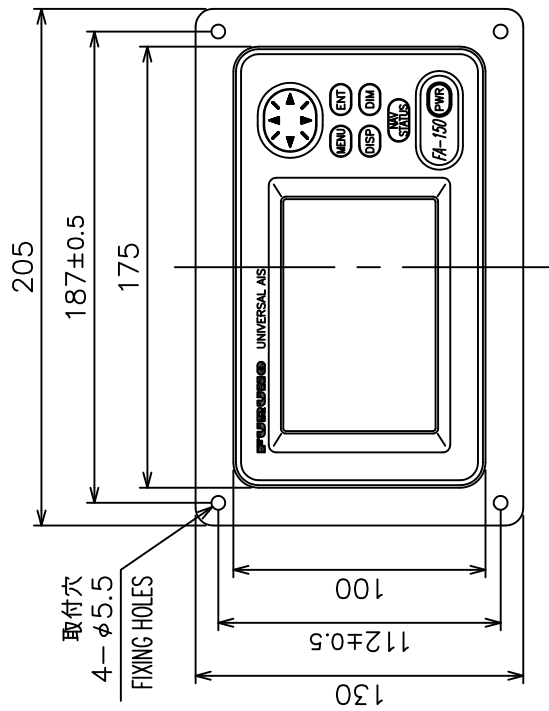
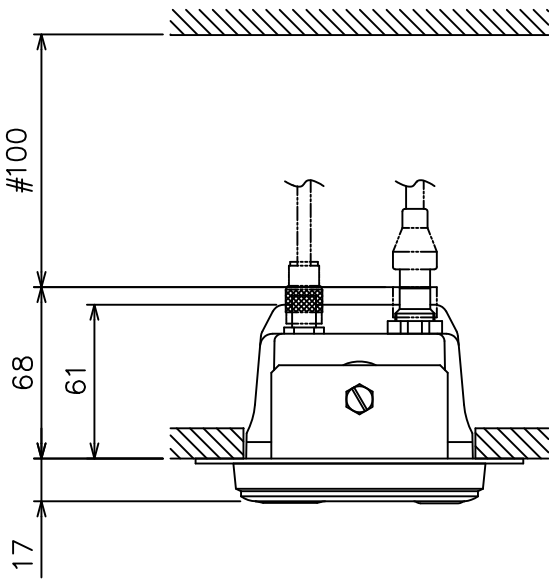

取付穴寸法図
CUTOUT DIMENSIONS

- 注 記
- 1) 指定外寸法公差は表 1 による。
 - 2) # 印寸法は最小サービスクリアランスとする。
 - 3) 取付用ネジはトラスネジ呼び径 5 × 2.0 を使用のこと。

- NOTE
1. TABLE 1 INDICATES TOLERANCE OF DIMENSIONS WHICH IS NOT SPECIFIED.
 2. #: MINIMUM SERVICE CLEARANCE.
 3. USE TAPPING SCREWS φ5x2.0 FOR FIXING THE UNIT.

DRAWN	14/Nov/2017	T.YAMASAKI	TITLE	FA-1502
CHECKED	14/Nov/2017	H.MAKI	名称	表示部 (埋込装備F)
APPROVED	15/Nov/2017	H.MAKI	外寸図	
SCALE	1/3	MASS 0.54 kg	NAME	MONITOR UNIT (FLUSH MOUNT F)
DWG.No.	C4431-G03-C	REF.No.	24-006-310G-0	OUTLINE DRAWING

表 1 TABLE 1

寸法区分 (mm) DIMENSION	公差 (mm) TOLERANCE
L ≤ 50	±1.5
50 < L ≤ 100	±2.5
100 < L ≤ 500	±3

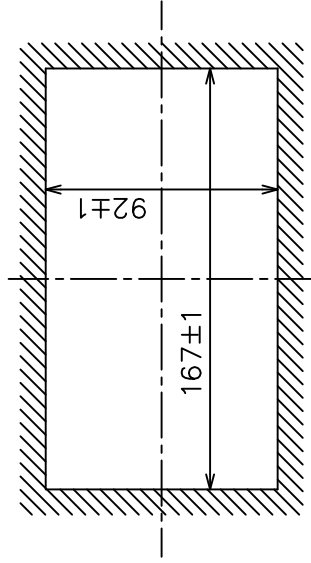
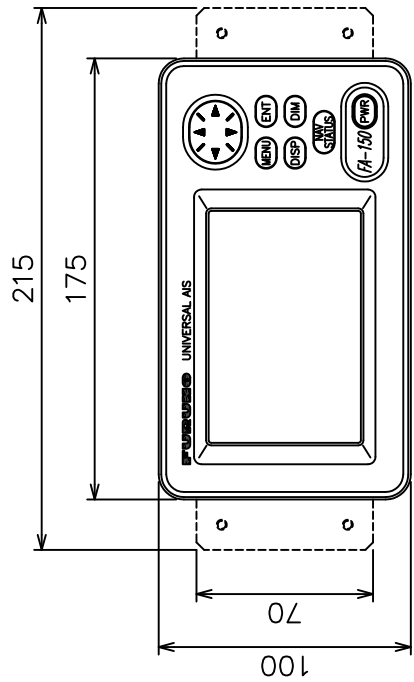
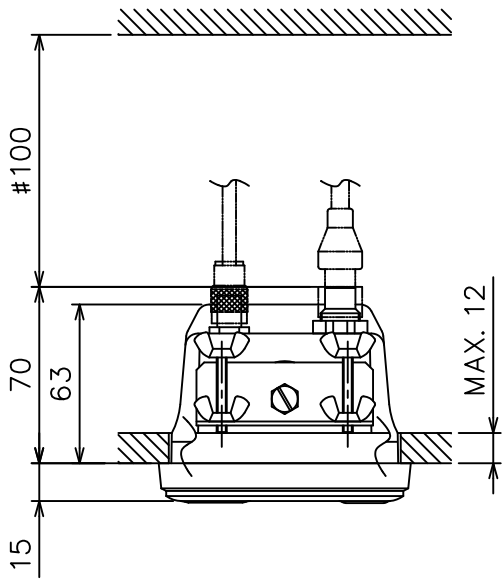

取付穴寸法 (参考)
CUTOUT DIMENSIONS

- 注記 1) 指定外の寸法公差は表 1 による。
2) # 印寸法は最小サービスマウント寸法とする。
- NOTE 1. TABLE 1 INDICATES TOLERANCE OF DIMENSIONS WHICH IS NOT SPECIFIED.
2. # MINIMUM SERVICE CLEARANCE.

DRAWN	14/Nov/2017	T. YAMASAKI	TITLE	FA-150Z
CHECKED	14/Nov/2017	H. MAKI	名称	表示部 (埋込装置 S)
APPROVED	15/Nov/2017	H. MAKI	外寸図	
SCALE	1/3	1/MASS 0.56 kg	NAME	MONITOR UNIT (FLASH MOUNT S)
DWG. No.	C4431-G04-B	REF. No.	24-006-320G-0	OUTLINE DRAWING



表 1 TABLE 1

寸法区分 (mm) DIMENSIONS	公差 (mm) TOLERANCE
L ≤ 50	± 1.5
50 < L ≤ 100	± 2.5
100 < L ≤ 500	± 3

- 注 記
- 1) 指定外の寸法公差は表 1 による。
 - 2) #印寸法は最小サービス空間寸法とする。
 - 3) 取付用ネジはM5ボルト、またはタッピンネジ呼び径5X20を使用のこと。
- NOTE
1. TABLE 1 INDICATES TOLERANCE OF DIMENSIONS WHICH IS NOT SPECIFIED.
 2. #: MINIMUM SERVICE CLEARANCE.
 3. USE M5 BOLTS OR SELF-TAPPING SCREWS 5X20 FOR FIXING THE UNIT.

DRAWN	Nov. 22, '04 E. MIYOSHI	TITLE	FA-1501
CHECKED	TAKAHASHI. T	名称	トランスポンダ部
APPROVED	Y. Hatai	FA-150	外寸図
SCALE	1/4 MASS 7.3 ±10% kg	NAME	TRANSPONDER UNIT
DWG.No.	C4431-G02-B	24-006-110G-1	OUTLINE DRAWING

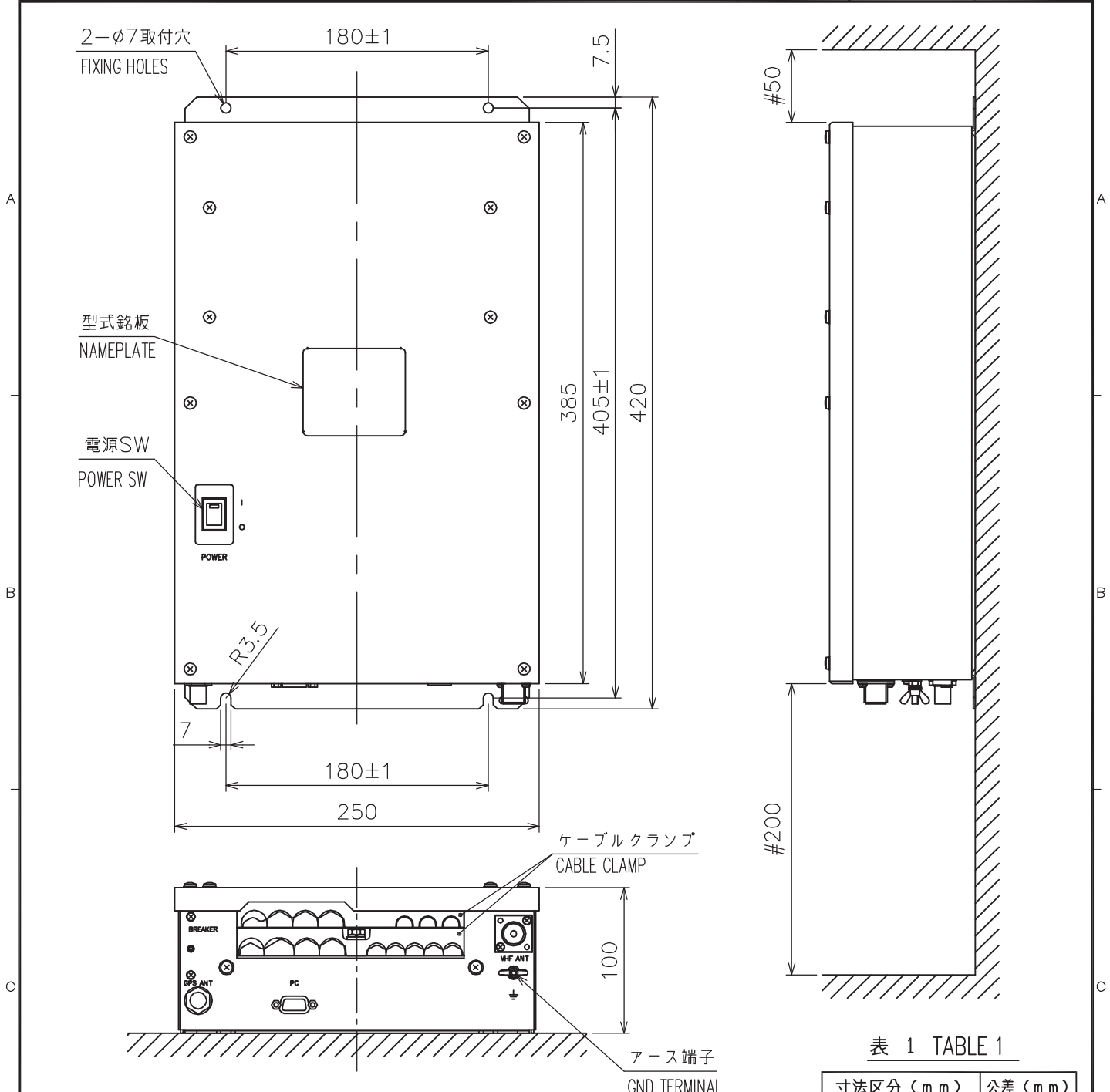
A

B

C

D



表1 TABLE 1

寸法区分(mm) DIMENSION	公差(mm) TOLERANCE
L ≤ 50	±1.5
50 < L ≤ 100	±2.5
100 < L ≤ 500	±3

1-14UNS1B

ねじ山数 (25.4mmにつき) : 14
 ピッチ : 1.8143 mm
 オネジ有効長さ : 19 mm以上
 オネジ有効径 : 24.17mm

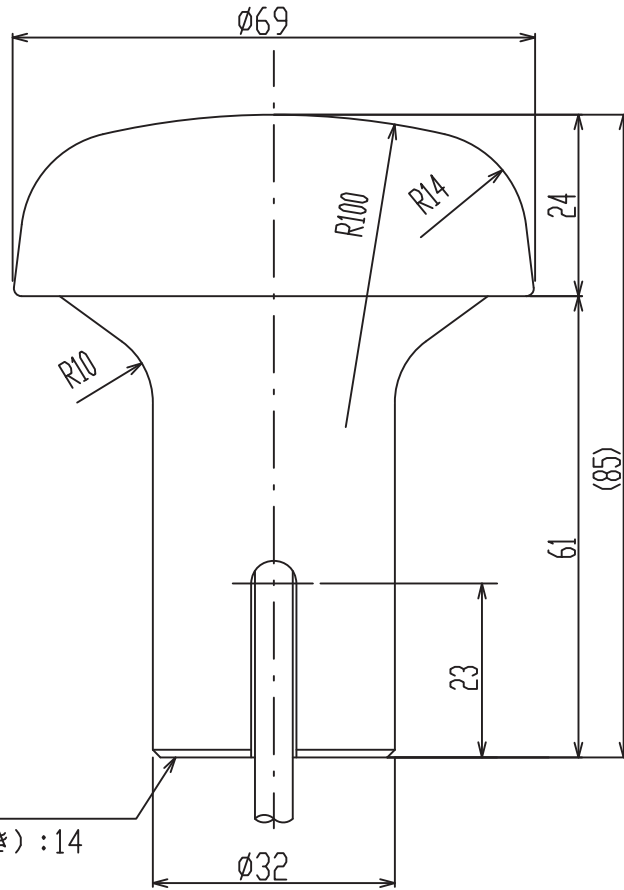
THREAD PER 25.4mm (1 INCH): 14
 PITCH: 1.8143 mm
 THREAD LENGTH: 19 mm OR MORE
 PITCH DIAMETER: 24.17mm



表2 TABLE 2

型式 TYPE	ケーブル長(m) CABLE LENGTH	プラグ PLUG	質量(kg±10%) MASS
GPA-017	10	TNC-P-3	0.6
GPA-017S	0.2	TNC-J-3	0.15

注記

指定外の寸法公差は表1による。

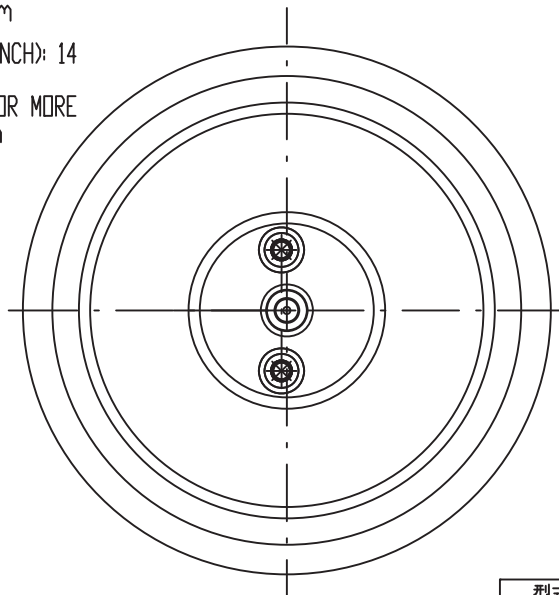
NOTE

TABLE 1 INDICATES TOLERANCE OF DIMENSIONS WHICH IS NOT SPECIFIED.

DRAWN Mar. 27 '07 T.YAMASAKI		TITLE GPA-017/017S
CHECKED Mar. 27 '07 T.TAKENO		名称 空中線部
APPROVED Mar. 27 '07 R.Esumi		外寸図
SCALE 1/1	MASS TABLE 2 表2参照	NAME ANTENNA UNIT
DWG.No. C4384-G04- L		OUTLINE DRAWING

1 2 3 4

寸法区分 (mm) DIMENSION	公差 (mm) TOLERANCE
$L \leq 50$	± 1.5
$50 < L \leq 100$	± 2.5
$100 < L \leq 500$	± 3

表 1 TABLE 1

A
B
C
D
E

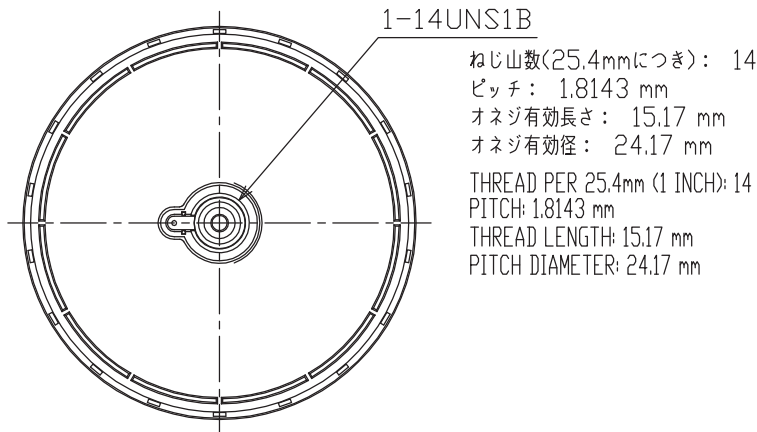
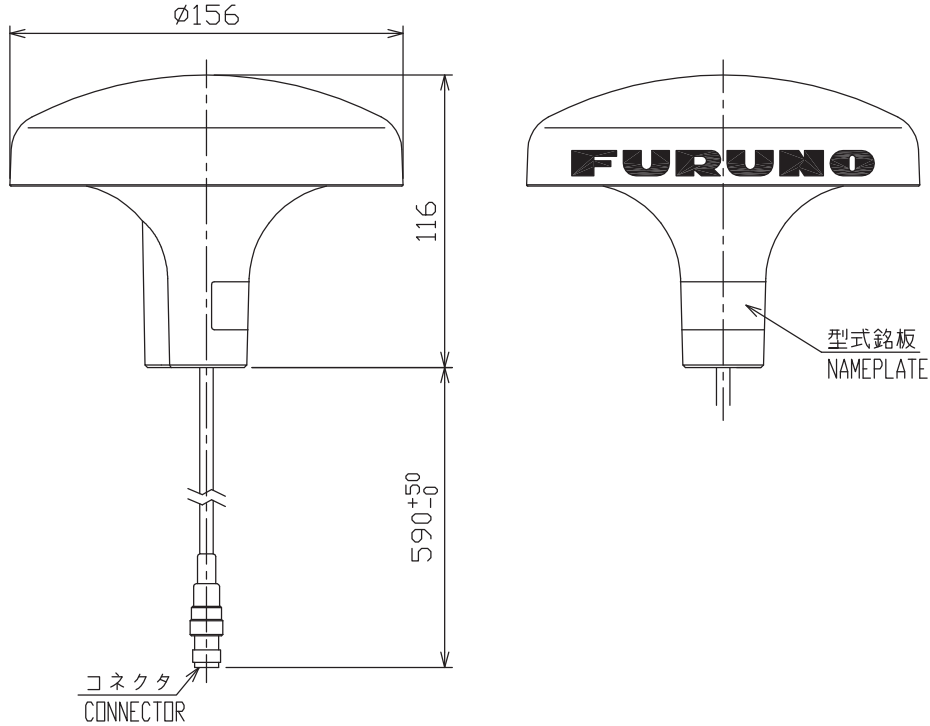

注 記 1) 指定外の寸法公差は表 1 による。
 NOTE 1. TABLE 1 INDICATES TOLERANCE OF DIMENSIONS.

DRAWN May 12 '03 T. YAMASAKI		TITLE GSC-001-FA
CHECKED May 12 '03 T. Matsuguchi		名称 GPS アンテナ部
APPROVED May 20 '03 T. Matsuguchi	FA-100	外寸図
SCALE 1/3	MASS $\pm 10\%$ 0.47 kg	NAME GPS ANTENNA UNIT
DWG.No. C4417-G07-B	質量はケーブルを含む。 MASS W/ CABLE.	24-003-330G-0 OUTLINE DRAWING

表2 TABLE 2

アンテナ型式 ANTENNA MODEL	FAB-151D	CX4-3/FEC
L(mm)	1245±15	1356±15
質量 MASS (kg±10%)	3.3	3.4

表1 TABLE 1

寸法区分 (mm) DIMENSION	公差 (mm) TOLERANCE
$L \leq 50$	±1.5
$50 < L \leq 100$	±2.5
$100 < L \leq 500$	±4
$500 < L \leq 1000$	±5
$1000 < L \leq 2000$	

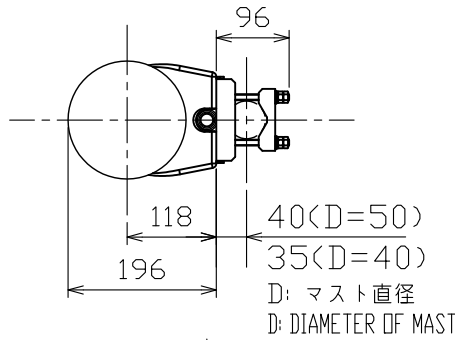

A

B

C

D

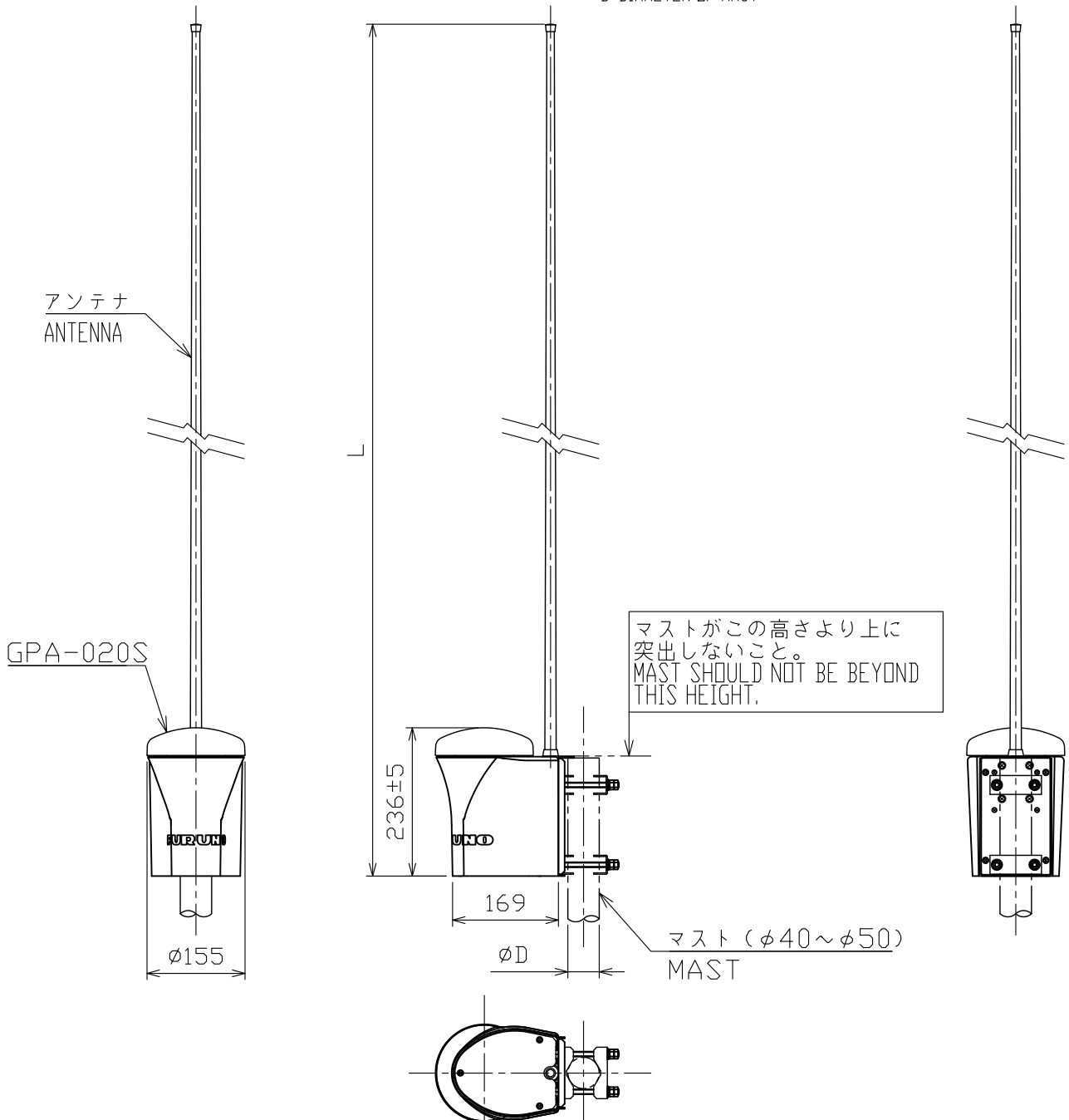

注 記 1) 指定外の寸法公差は表1による。

NOTE 1. TABLE 1 INDICATES TOLERANCE OF DIMENSIONS WHICH IS NOT SPECIFIED.

DRAWN 16/Nov/2018 T.YAMASAKI		TITLE GVA-100-T
CHECKED 16/Nov/2018 H.MAKI		名称 GPS/VHF 複合空中線部
APPROVED 20/Nov/2018 H.MAKI	FA-100/50/150/170	外寸図
SCALE 1/10	MASS 表2参照 TABLE 2	NAME GPS/VHF COMBINED ANTENNA
DWG. No. C4417-G02-K	REF. No. 24-003-301G-4	OUTLINE DRAWING

表2 TABLE 2

アンテナ型式 ANTENNA MODEL	FAB-151D	CX4-3/FEC
L(mm)	1245±15	1356±15
質量 MASS (kg±10%)	5.1	5.2

表1 TABLE 1

寸法区分 (mm) DIMENSION	公差 (mm) TOLERANCE
L ≤ 50	±1.5
50 < L ≤ 100	±2.5
100 < L ≤ 500	±3
500 < L ≤ 1000	±4
1000 < L ≤ 2000	±5

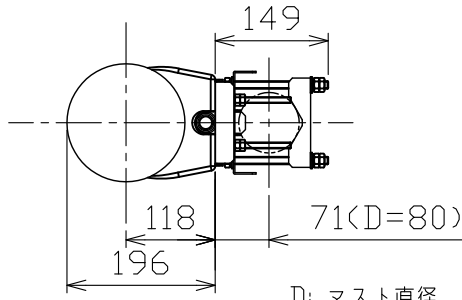

D: マスト直径
D: DIAMETER OF MAST

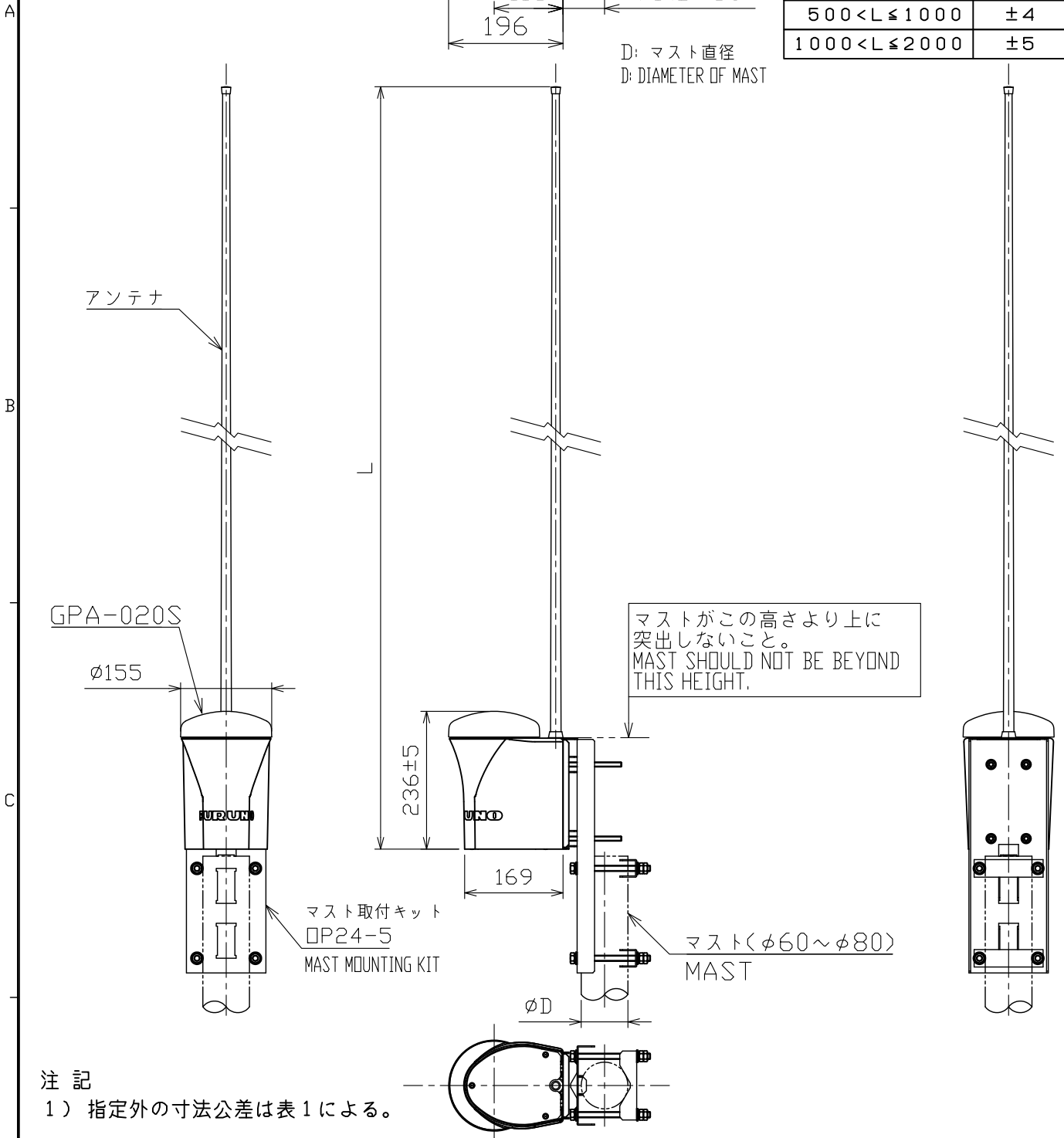

注記

1) 指定外の寸法公差は表1による。

NOTE

1. TABLE 1 INDICATES TOLERANCE OF DIMENSIONS WHICH IS NOT SPECIFIED.

DRAWN 19/Nov/2018 T.YAMASAKI	TITLE GVA-100-T
CHECKED 19/Nov/2018 H.MAKI	名称 GPS/VHF 複合空中線部 (取付キット)
APPROVED 20/Nov/2018 H.MAKI	外寸図
SCALE 1/10	NAME GPS/VHF COMBINED ANTENNA (MAST MOUNTING KIT)
DWG. No. C4417-G10-E	REF. No. 24-003-303G-4
MASS 表2参照 TABLE 2	OUTLINE DRAWING

寸法区分 (mm) DIMENSION	公差 (mm) TOLERANCE
$L \leq 50$	± 1.5
$50 < L \leq 100$	± 2.5
$100 < L \leq 500$	± 3

表 1 TABLE 1

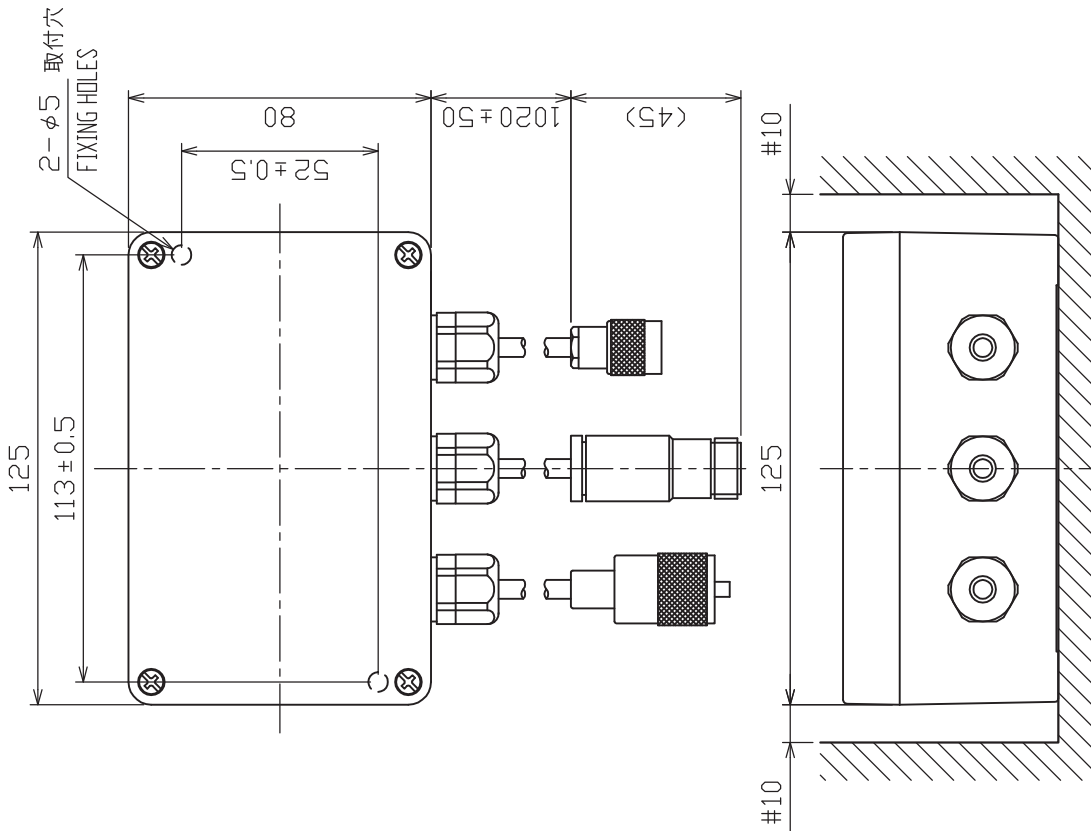

- 注 記 1) # 印寸法は最小サービス空間寸法とする。
 2) 指定外の寸法公差は表 1 による。
 3) 取付用ネジは + ナバタツピンネジ 4 x 3.0 を使用のこと。
 NOTE 1. # RECOMMENDED SERVICE CLEARANCE.
 2. TABLE 1 INDICATES TOLERANCE OF DIMENSIONS.
 3. USE TAPPING SCREWS 4x3.0 FOR FIXING THE UNIT.

DRAWN	Jan. 9 '03	T. YAMASAKI	TITLE	DB-1
CHECKED	Jan. 9 '03	Y. KIMURA	名称	分配器
APPROVED	Jan. 9 '03	Y. Kimura	外寸図	FA-100
SCALE	1/2	MASS 0.85 kg	NAME	DISTRIBUTOR
DWG No.	C4417-G04-C		24-003-320G-4	
			OUTLINE DRAWING	

表 1 TABLE 1

寸法区分 (mm) DIMENSION	公差 (mm) TOLERANCE
L ≤ 50	± 1.5
50 < L ≤ 100	± 2.5
100 < L ≤ 500	± 3

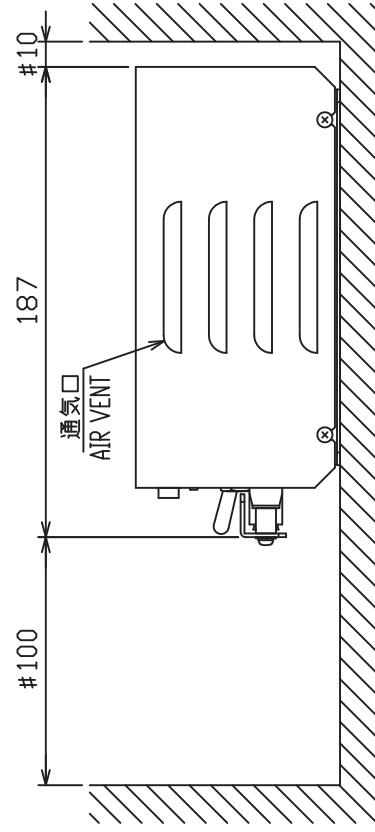
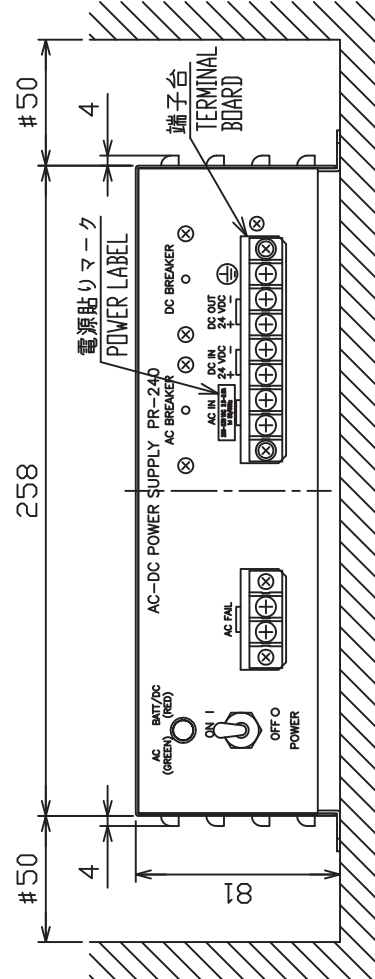
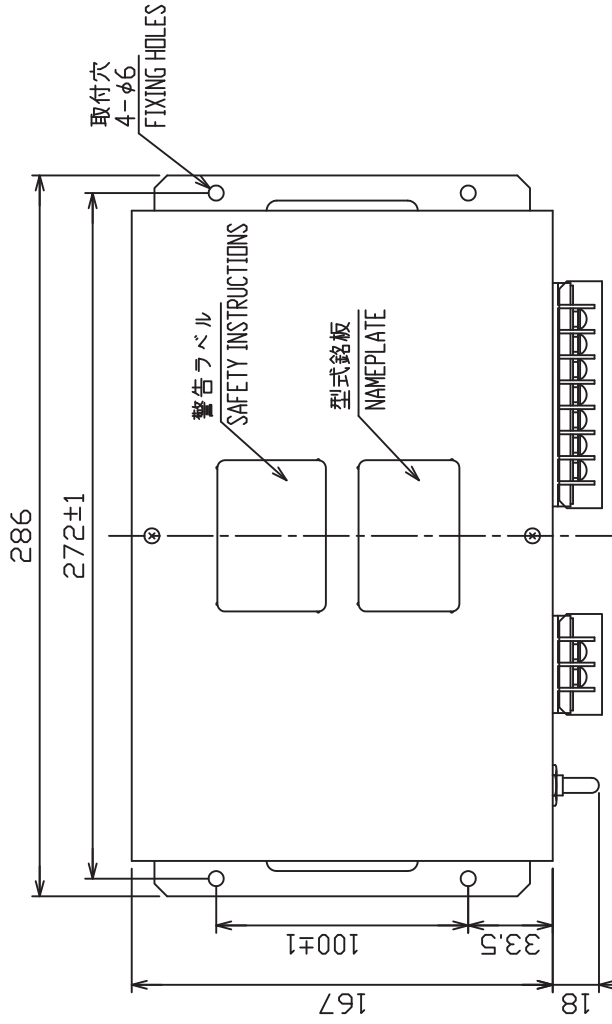

- 注 記 1) 指定なき寸法公差は表 1 による。
 2) #印寸法は最小サービスマージンを考慮して指定されている。
 3) 取付用ネジは + トラスタックピンネジ 呼び径 4 × 1.6 を使用のこと。
- NOTE 1. TABLE 1 INDICATES TOLERANCE OF DIMENSIONS WHICH IS NOT SPECIFIED.
 2. # MINIMUM SERVICE CLEARANCE.
 3. USE TAPPING SCREWS φ4x1.6 FOR FIXING THE UNIT.

DRAWN	25/Sep/09 T.YAMASAKI	TITLE	PR-240
CHECKED	25/Sep/09 T.TAKENO	名称	AC/DC電源ユニット
APPROVED	26/Oct/09 R.Esumi	外寸図	
SCALE	1/3	NAME	AC/DC POWER SUPPLY UNIT
DWG No.	C5003-603-J	REF. No.	24-003-500G-4
			OUTLINE DRAWING

表1 (Table1)

寸法区分 (mm) Dimension	公差 (mm) Tolerance
$L \leq 50$	± 1.5
$50 < L \leq 100$	± 2.5
$100 < L \leq 500$	± 3
$500 < L \leq 1000$	± 4
$1000 < L \leq 2000$	± 5

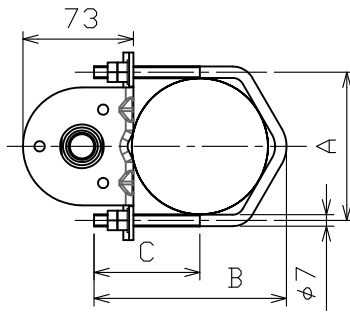

品目	ITEM	型式 MODEL	材質 (JIS) MATERIAL
アンテナ金具	FIXING PLATE	N173F/174F	SUS316
座金	WASHER		SUS316
ナット	NUT		C3603B
Uボルト	U-BOLT		SUS316
座金・ナット	WASHER/NUT	M8	SUS316

表3 (Table3)

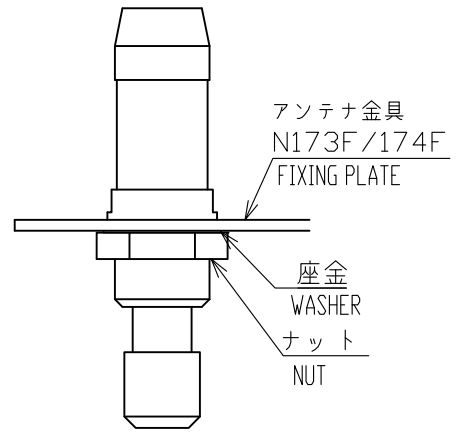

取付部詳細 (尺度:1/2)
DETAIL FOR FIXING (SCALE:1/2)

*:斜線部は自己融着テープを巻き
さらにビニールテープを巻いて
防水処理をすること。
SEAL WITH SELF-BONDING TAPE AND
PVC TAPE FOR WATERTIGHT.

マストがこの高さより上に
突出しないこと。
MAST SHOULD NOT BE BEYOND
THIS HEIGHT.

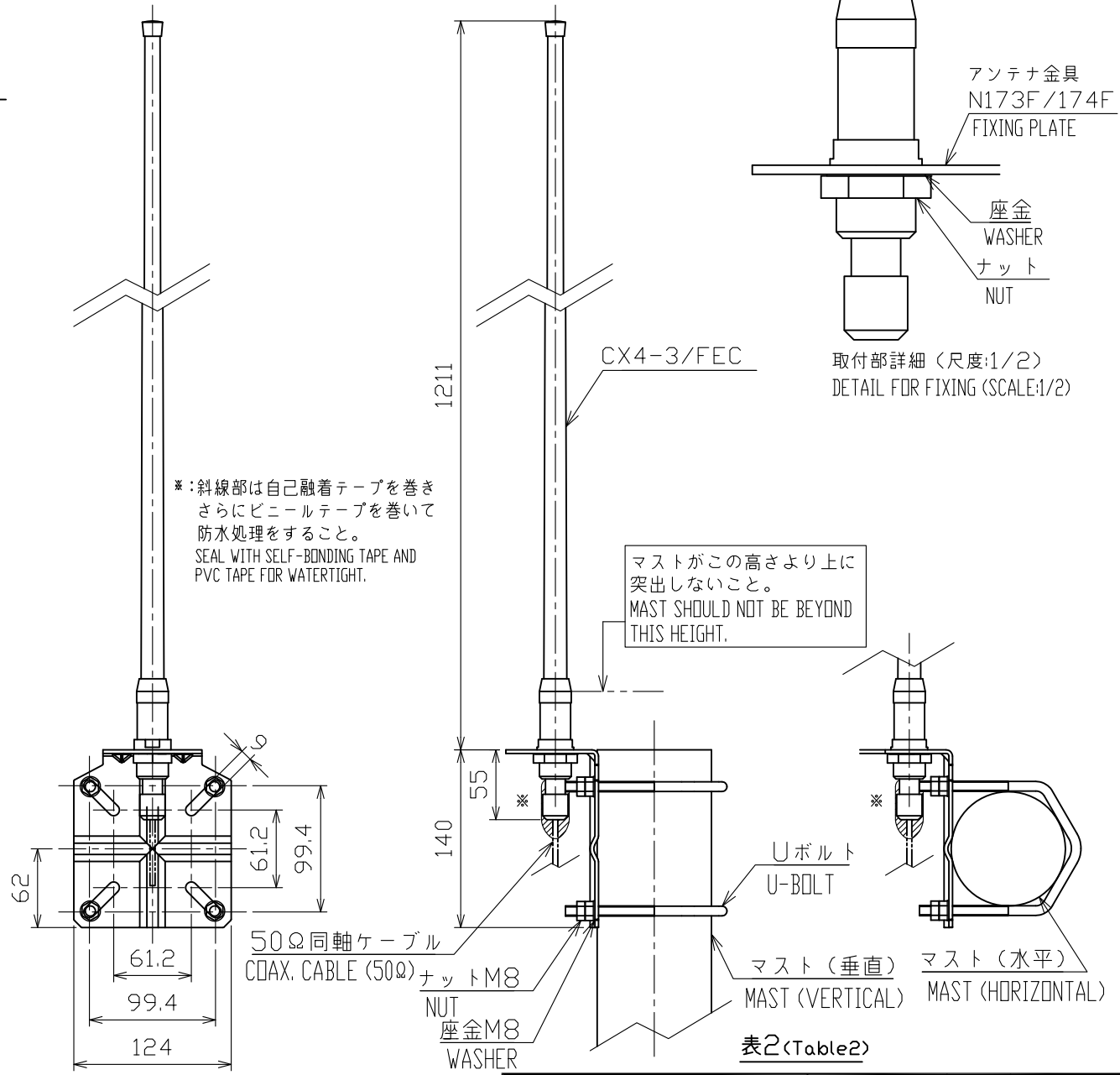

注記 1) 指定外の寸法公差は表1による。

NOTE 1. TABLE 1 INDICATES TOLERANCE OF DIMENSIONS WHICH IS NOT SPECIFIED.

アンテナ金具型式 FIXING PLATE	Uボルト型式 U-BOLT TYPE	適合マスト径 MAST DIAMETER	A	B	C
N173F/FEC	412-0051-01	$\phi 49 - \phi 90$	98	127	70
N174F/FEC	412-0024-02	$\phi 30 - \phi 61$	69	117	83

表2 (Table2)

DRAWN	10/Jan/2019	T.YAMASAKI	TITLE	CX4-3/FEC		
CHECKED	10/Jan/2019	H.MAKI	名称	アンテナ		
APPROVED	11/Jan/2019	H.MAKI	外寸図			
SCALE	1/5	MASS 1.2 ±10% kg	質量は取付金具を含まず。 MASS DOES NOT INCLUDE FIXTURE.	NAME	ANTENNA	
DWG. No.	C5013-G04-F		REF. No.	05-104-355G-2		
				OUTLINE DRAWING		

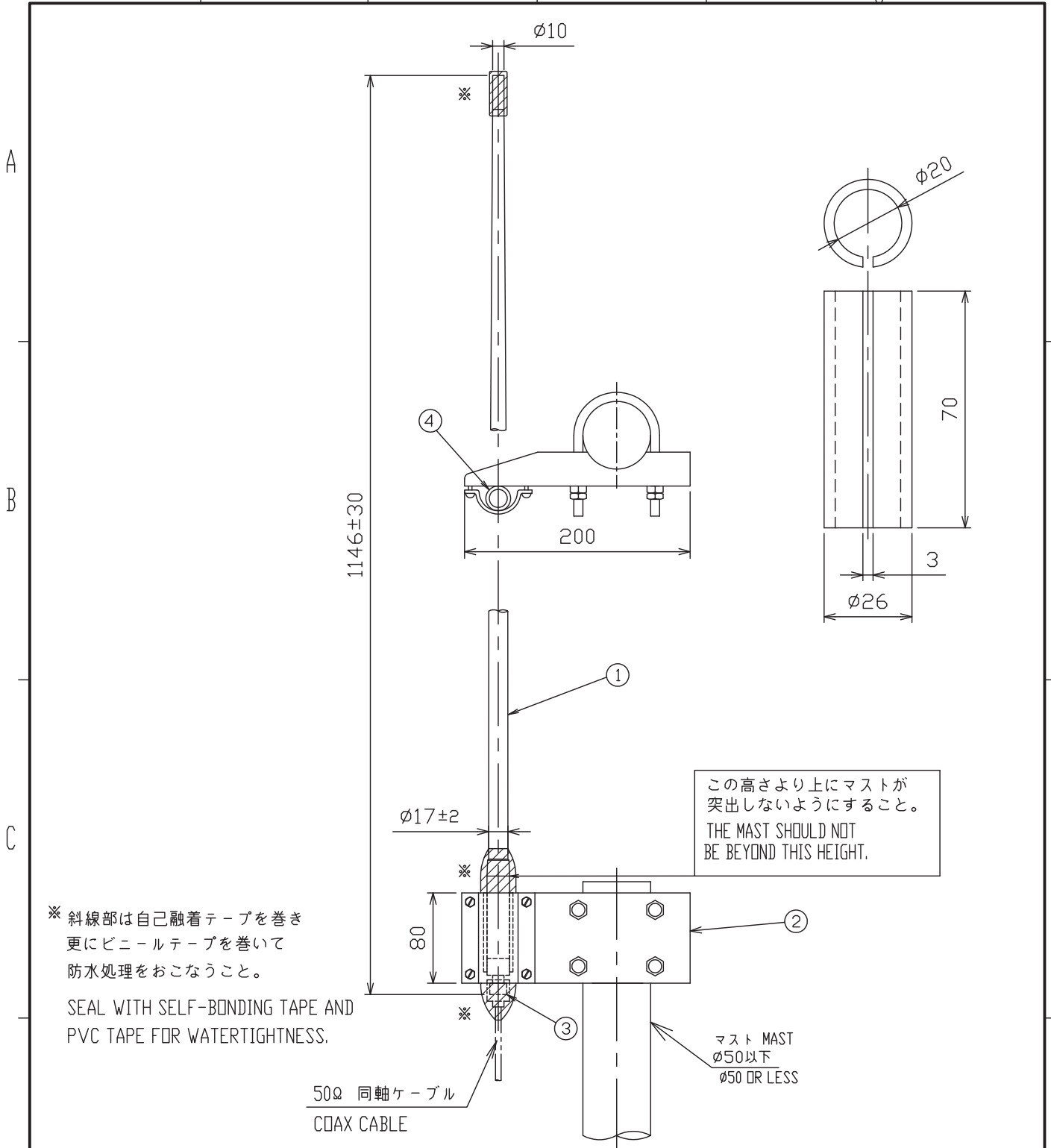

※ 斜線部は自己融着テープを巻き更にビニールテープを巻いて防水処理をおこなうこと。

SEAL WITH SELF-BONDING TAPE AND PVC TAPE FOR WATERTIGHTNESS.

50Ω 同軸ケーブル
COAX CABLE

この高さより上にマストが突出しないようにすること。
THE MAST SHOULD NOT BE BEYOND THIS HEIGHT.

マスト MAST
φ50以下
φ50 OR LESS

4	固定用パイプ LINER PIPE	硬質塩ビ VINYL CHLORIDE	1		
3	同軸コネクタ COAX. CONNECTOR		1		M-R
2	アンテナ取付金具 ANTENNA BRACKET	SUS	1 式 SET	4-310071	0.6kg
1	アンテナ棒 ANTENNA ELEMENT	FRP	1		0.25kg
品番 ITEM	品名 NAME	材質 MATERIAL	数量 Q.TY	図番 DWG.No.	摘要 REMARKS

DRAWN	4/Aug/2017	I.YAMASAKI	TITLE	FAB-151D
CHECKED	4/Aug/2017	H.MAKI	名称	150MHz ホイップアンテナ
APPROVED	10/Aug/2017	H.MAKI		外寸図
SCALE	1/5	MASS 0.85 ±10% kg	NAME	150MHz WHIP ANTENNA
DWG.No.	C5013-019-L	4-110718		OUTLINE DRAWING

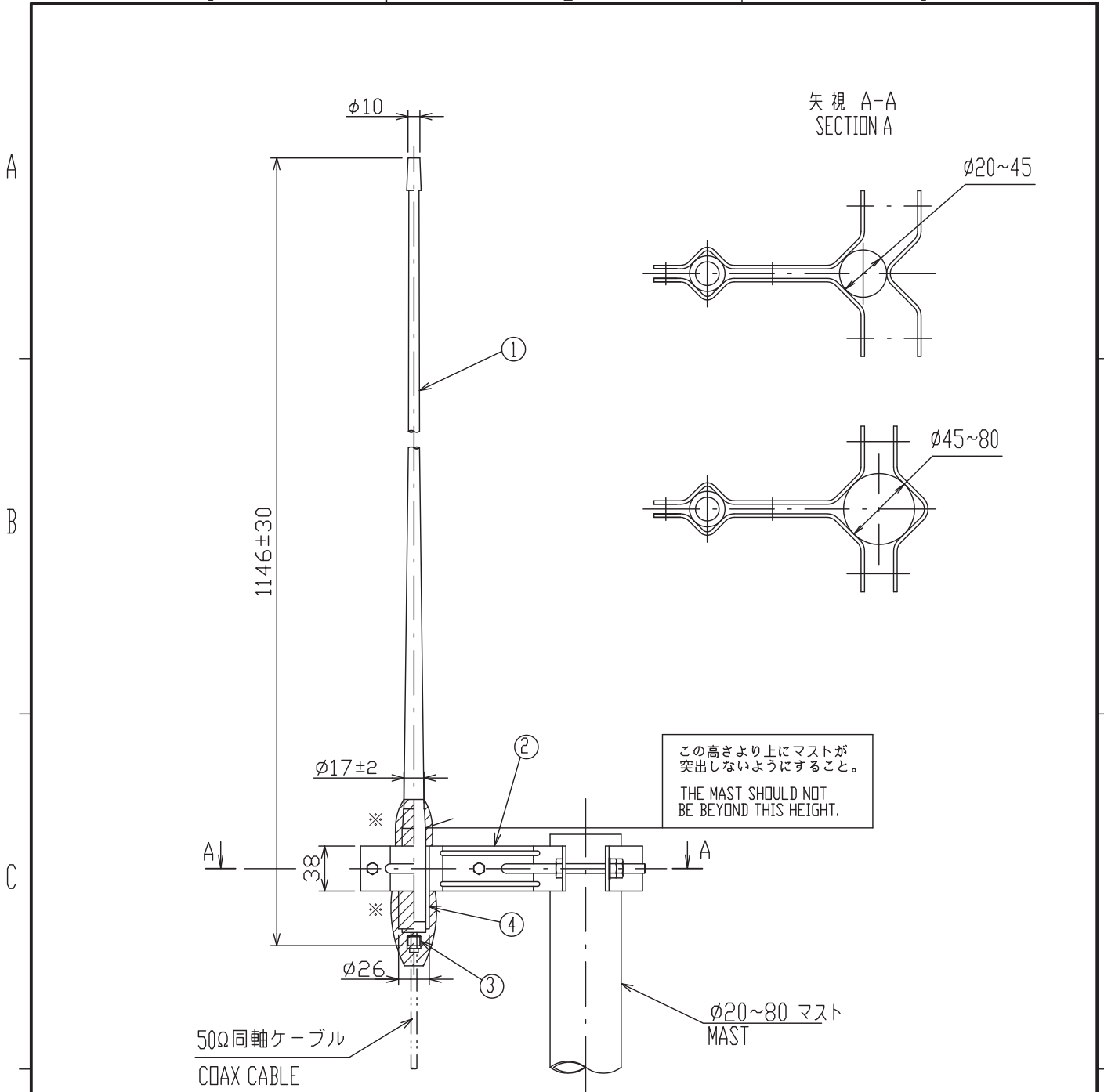

※： 斜線部は自己融着テープを巻き
さらにビニールテープを巻いて
防水処理を行うこと。
SEAL WITH SELF-BONDING TAPE AND
PVC TAPE FOR WATERTIGHTNESS.

4	固定用パイプ LINEAR PIPE	硬質塩ビ VINYL CHLORIDE	1		
3	同軸コネクタ COAX. CONNECTOR		1		M-R
2	アンテナ取付金具 ANTENNA BRACKET	SUS316L	1 式 SET	M-15AS	t2.5
1	アンテナ棒 ANTENNA ELEMENT	FRP	1	FAB-151D	0.25 kg
品番 ITEM	品 名 NAME	材 質 MATERIAL	数 量 QTY	図 番 DWG. No.	備 考 REMARKS

DRAWN	4/Aug/2017 T.YAMASAKI	TITLE	FAB-151D + M-15AS1
CHECKED	4/Aug/2017 H.MAKI	名称	150MHzホイップアンテナ(取付金具)
APPROVED	10/Aug/2017 H.MAKI	外寸図	
SCALE	1/5 MASS 0.7 ±10% kg	質量は取付金具を含む。 MASS INCLUDES BRACKET.	NAME 150MHz WHIP ANTENNA w/ BRACKET
DWG. No.	C5011-042-G	REF. No.	OUTLINE DRAWING

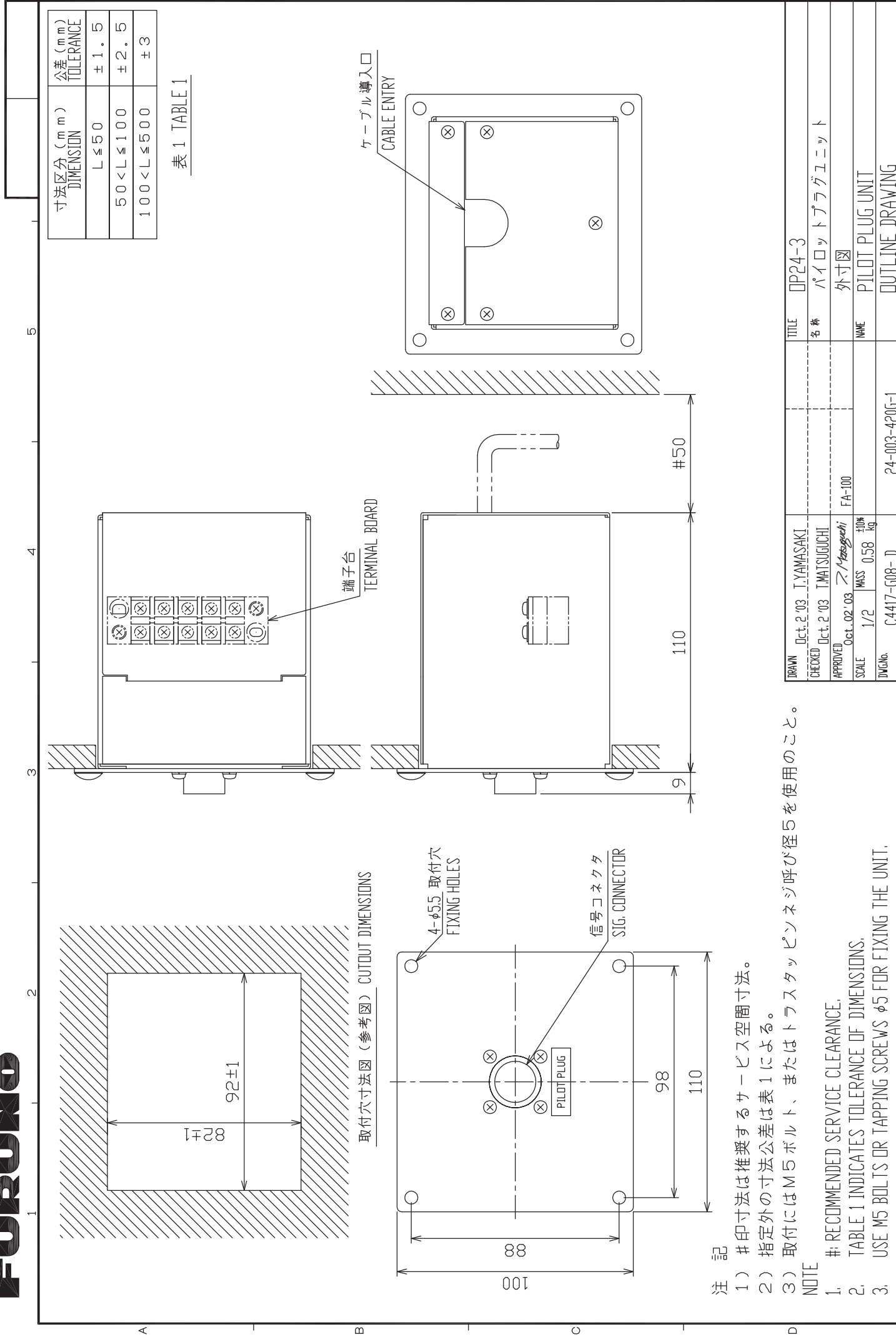

寸法区分 (mm) DIMENSION	公差 (mm) TOLERANCE
$L \leq 50$	± 1.5
$50 < L \leq 100$	± 2.5
$100 < L \leq 500$	± 3

表 1 TABLE 1

注 記

- 1) #印寸法は推奨するサービス空間寸法。
 - 2) 指定外の寸法公差は表 1 による。
 - 3) 取付には M5 ボルト、またはトラスタック ピンネジ呼び径 5 を使用のこと。
- NOTE
1. # RECOMMENDED SERVICE CLEARANCE.
 2. TABLE 1 INDICATES TOLERANCE OF DIMENSIONS.
 3. USE M5 BOLTS OR TAPPING SCREWS $\phi 5$ FOR FIXING THE UNIT.

DRAWN	Oct. 2 '03	T. YAMASAKI	TITLE	DP24-3
CHECKED	Oct. 2 '03	T. MATSUGUCHI	名称	パイロットプラグユニット
APPROVED	Oct. 02 '03	伊藤 誠	外寸図	
SCALE	1/2	MASS 0.58 kg	NAME	PILOT PLUG UNIT
DWG. No.	C4417-G08-D			OUTLINE DRAWING
	24-003-420G-1			

取付位置
MOUNTING LOCATION

他の機器のアンテナから下の図の距離以上離す。
THIS FIGURE SHOWS THE SEPARATION DISTANCES FROM OTHER ANTENNAS TO AVOID MUTUAL INTERFERENCE.

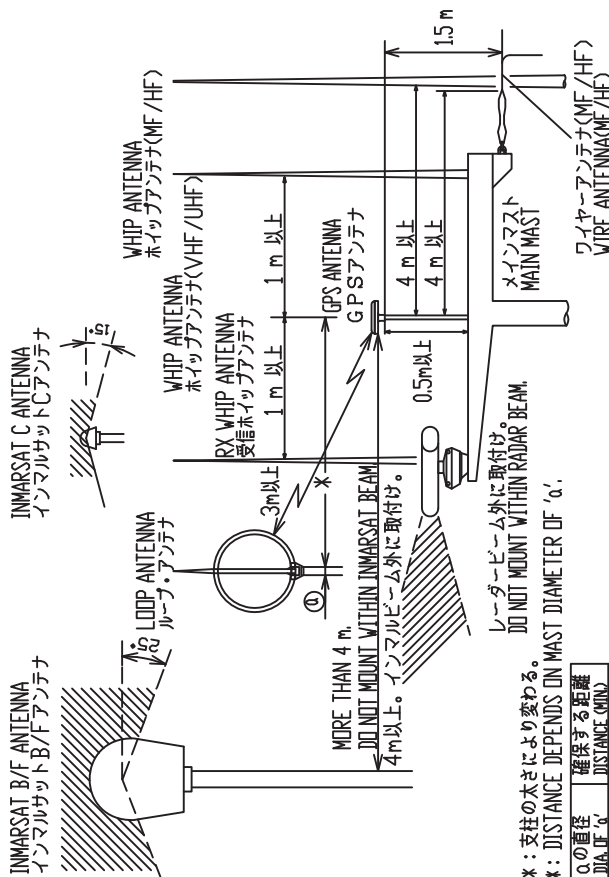

B) スタンションやパルピットにつけるとき
L型アンテナベース No.13-RC5160
(取付可能レール直径:φ19~φ32)
(コード番号:000-806-114)

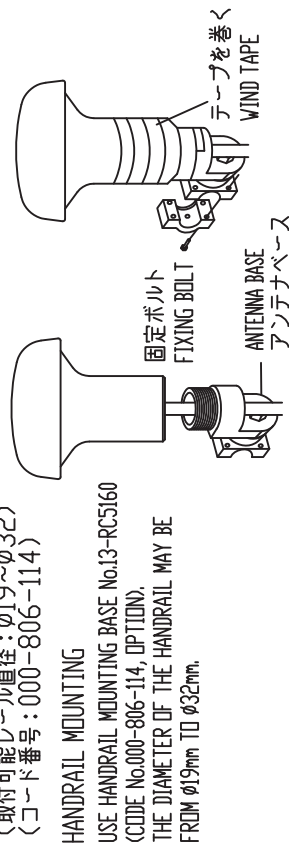

注記 1) パイプやアンテナベースはアンテナユニットにねじ込んだ後に固定する。
2) アンテナを固定するときはパイプ(アンテナベース)をアンテナにねじ込むこと。アンテナ脚をねじるとコネクタ部やケーブルに無理がかかり、故障の原因となる。

NOTE 1. FASTEN PIPE(ANTENNA BASE) TO ANTENNA UNIT FIRST THEN FIX THEM TO MAST OR HANDRAIL.
2. WHEN FIXING ANTENNA, TURN PIPE OR ANTENNA BASE; NOT THE ANTENNA.
TURNING THE ANTENNA MAY TWIST THE CABLE AND PLACE STRESS ON CONNECTOR.

A) マストへの取付け
MAST MOUNTING

α) マスト取付金具CP20-0111(工事材料)でマストに固定する。
USE MAST MOUNTING KIT CP20-0111.

β) パイプのみを使うとき
USE A PIPE ONLY.

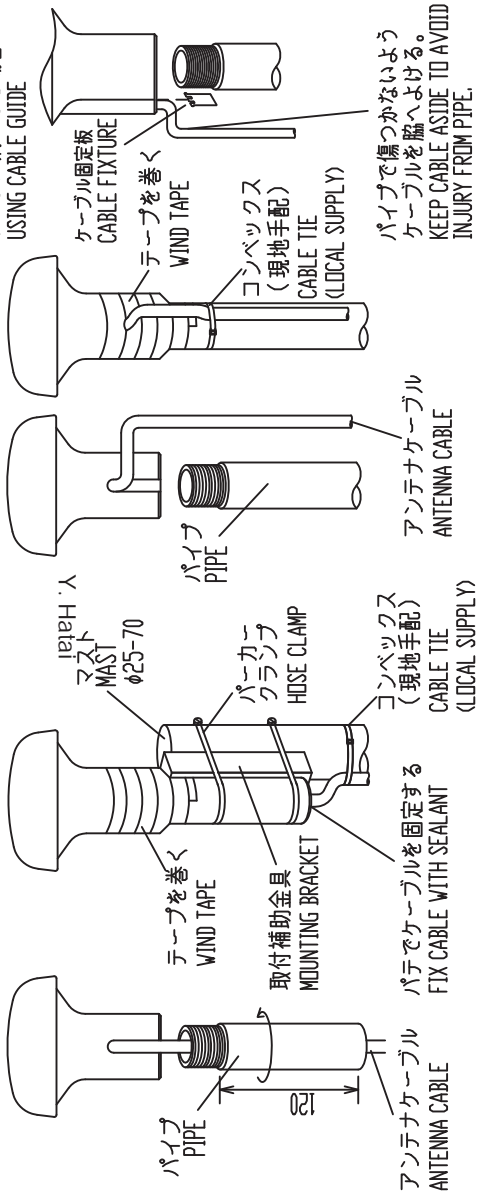

C) 取付ける場所が傾斜しているとき
ANTENNA BASE MOUNTING

オプションのアンテナベースを使う。
USE OPTIONAL ANTENNA BASE.

傾斜 INCLINATION	5° - 33°	32° - 65°	65° - 98°
取付方法 MOUNTING METHOD			
アンテナベース型式 ANT. BASE TYPE	直型アンテナベース RIGHT ANGLE ANTENNA BASE No.13-QA330	L型アンテナベース L-TYPE ANTENNA BASE No.13-QA310	L型アンテナベース L-TYPE ANTENNA BASE No.13-QA310
コード番号 CODE No.	000-803-239	000-803-240	000-803-240

アンテナベース基部
MOUNTING DIMENSIONS OF ANTENNA BASE.

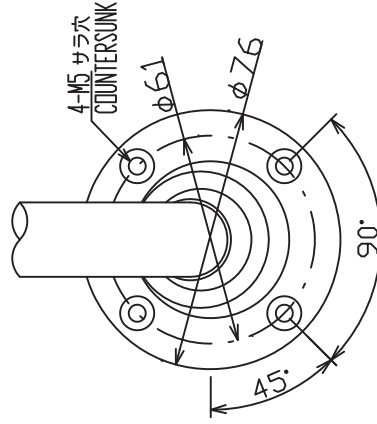

DRAWN 14/MAY/2014 T.YAMASAKI
CHECKED 14/MAY/2014 H.MAKI
APPROVED 15/May/2014 H.MAKI
SCALE MASS
Drawing No. C4384-Y01-F

TITLE	名称	空中線部	装備要領図	ANTENNA UNIT	INSTALLATION PROCEDURE
GPA series					

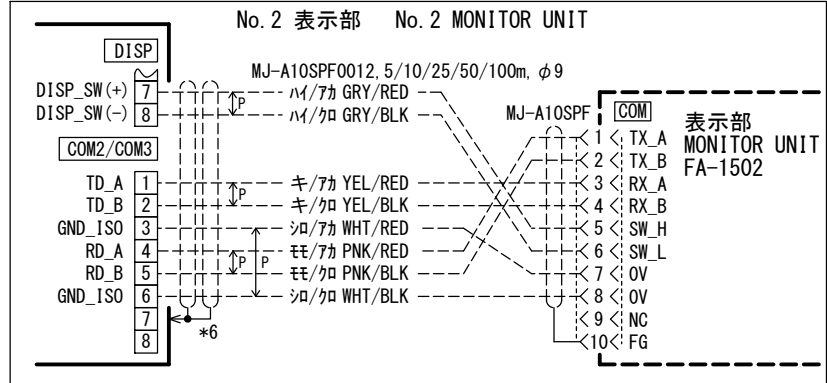
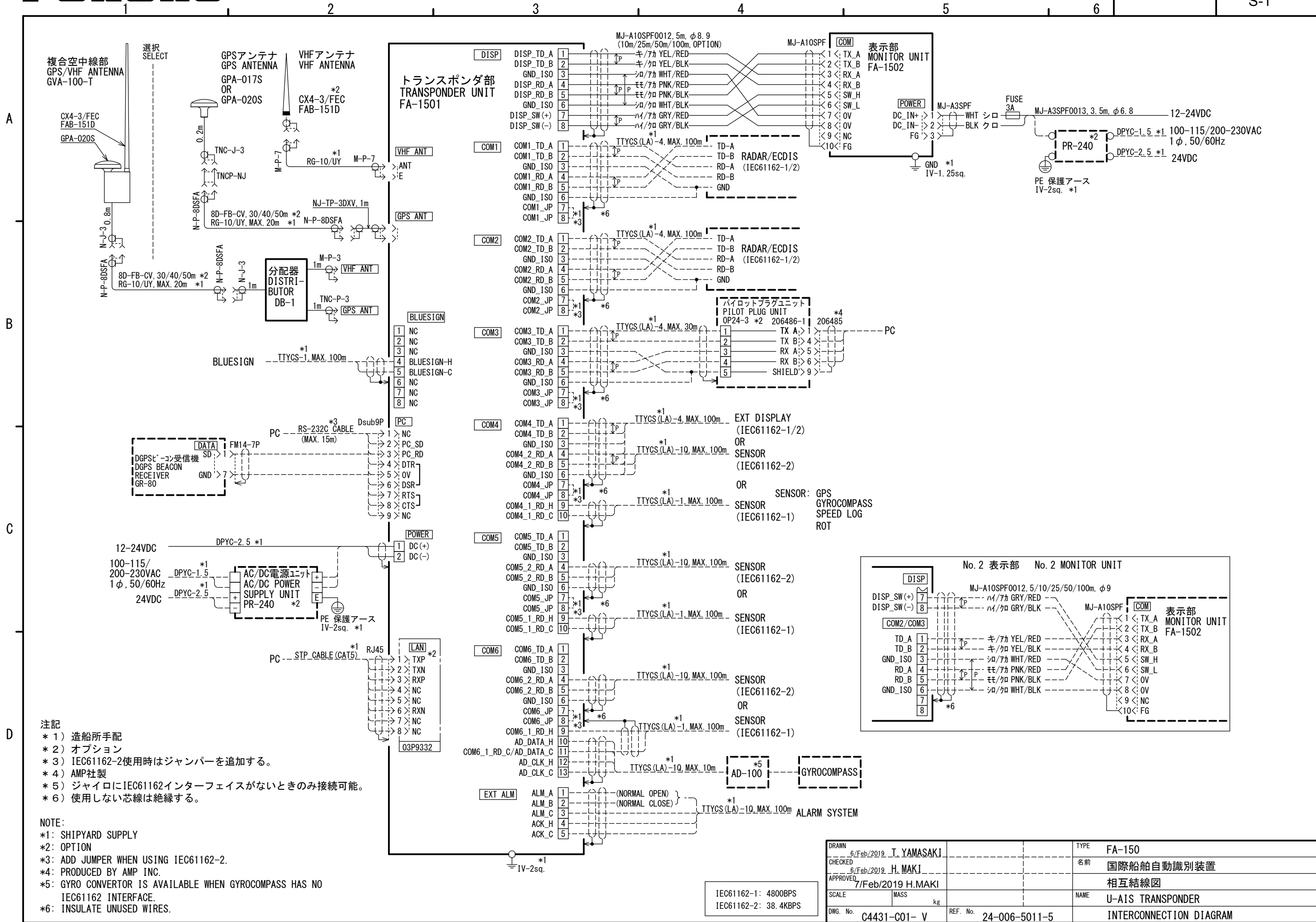

注記
* 1) 造船所手配
* 2) オプション
* 3) IEC61162-2使用時はジャンパーを追加する。
* 4) AMP社製
* 5) ジャイロにIEC61162インターフェイスがないときのみ接続可能。
* 6) 使用しない芯線は絶縁する。

NOTE:
*1: SHIPYARD SUPPLY
*2: OPTION
*3: ADD JUMPER WHEN USING IEC61162-2.
*4: PRODUCED BY AMP INC.
*5: GYRO CONVERTOR IS AVAILABLE WHEN GYROCOMPASS HAS NO IEC61162 INTERFACE.
*6: INSULATE UNUSED WIRES.

DRAWN	6/Feb/2019 T. YAMASAKI	TYPE	FA-150
CHECKED		名前	国際船舶自動識別装置
APPROVED	6/Feb/2019 H. MAKI		相互結線図
SCALE	MASS kg	NAME	U-AIS TRANSPONDER
DWG. No.	C4431-C01-V	REF. No.	24-006-5011-5
			INTERCONNECTION DIAGRAM