

**FURUNO**

**Installation Manual**  
**SSB RADIO TELEPHONE**  
**Model FS-1575/FS-2575/FS-5075**

---

<b>SAFETY INSTRUCTIONS .....</b>	<b>i</b>
<b>SYSTEM CONFIGURATION .....</b>	<b>iii</b>
<b>EQUIPMENT LIST .....</b>	<b>iv</b>
<b>1. HOW TO INSTALL THE SYSTEM .....</b>	<b>1-1</b>
1.1 Control Unit FS-2575C.....	1-1
1.2 Antenna Coupler AT-1575, AT-5075 .....	1-3
1.3 Transceiver Unit FS-1575T, FS-2575T, FS-5075T .....	1-6
1.4 Handset HS-2003 .....	1-6
1.5 Antenna.....	1-7
1.6 How to Install Optional Equipment.....	1-8
<b>2. WIRING.....</b>	<b>2-1</b>
2.1 Antenna Coupler .....	2-4
2.2 Transceiver Unit.....	2-10
2.3 Control Unit.....	2-13
2.4 External Equipment.....	2-13
2.5 AC-DC Power Supply Unit PR-300/PR-850A (option) .....	2-16
2.6 Automatic Antenna Switch AS-102 (option) .....	2-19
<b>3. INITIAL SETTINGS.....</b>	<b>3-1</b>
3.1 How to Initialize the Control Unit and Transceiver Unit.....	3-1
3.2 How to Enter MMSI.....	3-1
3.3 Performance Check .....	3-2
3.4 System Setup.....	3-2
3.5 Alarm Contact Signal .....	3-9
3.6 I/O Data.....	3-10
<b>APPENDIX 1 JIS CABLE GUIDE .....</b>	<b>AP-1</b>
<b>PACKING LISTS .....</b>	<b>A-1</b>
<b>OUTLINE DRAWINGS .....</b>	<b>D-1</b>
<b>INTERCONNECTION DIAGRAMS .....</b>	<b>S-1</b>



**FURUNO ELECTRIC CO., LTD.**

[www.furuno.com](http://www.furuno.com)

All brand and product names are trademarks, registered trademarks or service marks of their respective holders.

**ECF**

(Elemental Chlorine Free)

The paper used in this manual  
is elemental chlorine free.

**FURUNO ELECTRIC CO., LTD.**

9-52 Ashihara-cho,  
Nishinomiya, 662-8580, JAPAN

• FURUNO Authorized Distributor/Dealer

All rights reserved. Printed in Japan

Pub. No. IME-56770-Q1

(YOSH) FS-1575/2575/5075

A : JUL. 2011

Q1 : AUG. 25, 2020





0 0 0 1 9 2 6 8 9 1 4





# SAFETY INSTRUCTIONS

The installer must read the safety instructions before attempting to install the equipment.

 <b>DANGER</b>	Indicates a potentially hazardous situation which, if not avoided, will result in death or serious injury.
 <b>WARNING</b>	Indicates a potentially hazardous situation which, if not avoided, could result in death or serious injury.
 <b>CAUTION</b>	Indicates a potentially hazardous situation which, if not avoided, may result in minor or moderate injury.

 Warning, Caution	 Prohibitive Action	 Mandatory Action
--	--	--

 **DANGER**

 **Never touch the SSB antenna, antenna coupler or lead-in insulator when the SSB radio-telephone is transmitting.**

High voltage that will cause death or serious injury is present at the locations shown in the illustration below.

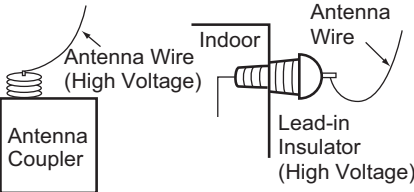

 **Do not touch the whip antenna or wire antenna.**

Electrical shock, serious injury or death can result if the antenna is touched during transmission.





 **WARNING**

 **Do not work inside the equipment unless totally familiar with electrical circuits.**

Hazardous voltage which can shock exists inside the equipment.

 **Turn off the power at the mains switchboard before beginning the installation. Post a sign near the switchboard to indicate it should not be turned on while the equipment is being installed.**

Fire, electrical shock or serious injury can result if the power is left on or is applied while the equipment is being installed.

 <b>CAUTION</b>	
	<p><b>Confirm that the power supply voltage is compatible with the voltage rating of the equipment.</b></p> <p>Connection to the wrong power supply can cause fire or damage the equipment.</p>
	<p><b>Ground the equipment.</b></p> <p>Ungrounded equipment can give off or receive electromagnetic interference or cause electrical shock.</p>
	<p><b>Handle the copper strap with care.</b></p> <p>The strap has sharp edges that can cut fingers.</p>

 <b>NOTICE</b>		
Follow the compass safe distances to prevent interference to a magnetic compass.		
Unit	Standard Compass	Steering Compass
FS-1575T	2.30 m	1.50 m
FS-2575T	2.40 m	1.50 m
FS-5075T	2.45 m	1.50 m
FS-2575C	0.60 m	0.40 m
HS-2003	1.50 m	0.95 m
AT-1575-AES	0.85 m	0.55 m
AT-1575-SUS	0.75 m	0.45 m
AT-5075	0.80 m	0.50 m
PP-520	1.00 m	0.60 m
IC-350	1.20 m	0.75 m
SEM-21Q	2.20 m	1.50 m
PR-850A	1.00 m	0.70 m
IB-585	0.85 m	0.55 m
AS-102	0.65 m	0.40 m
IF-8500	1.05 m	0.70 m
5139U or 5139U BLACK	0.30 m	0.30 m
SKB-E3U	0.70 m	0.45 m
PR-300	0.90 m	0.70 m

# SYSTEM CONFIGURATION

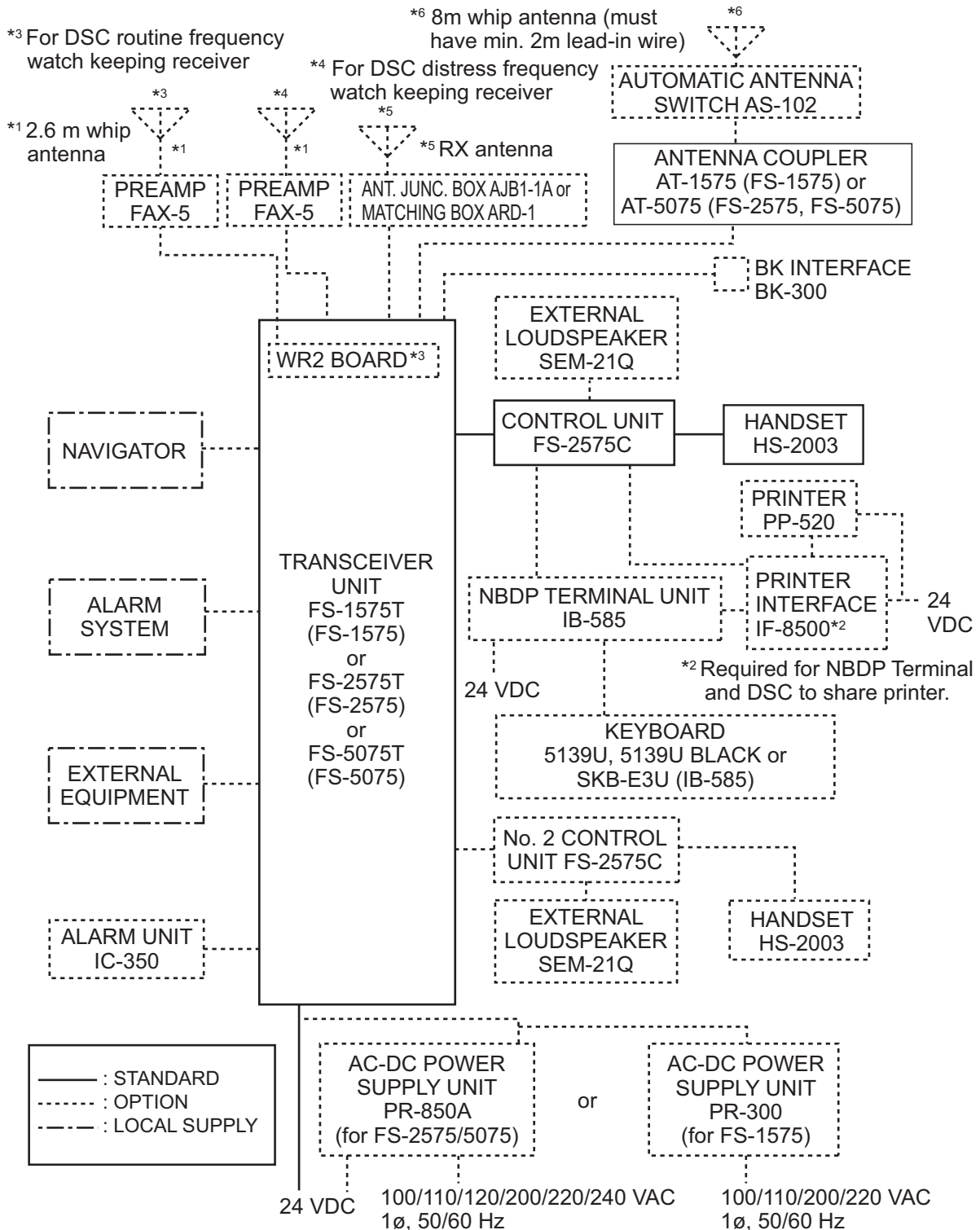

**CATEGORY OF UNITS (required by IEC60945):**

Unit	Category
Preamp Unit	Exposed to the weather (For installation on the open deck)
Antenna Coupler	Exposed to the weather or protected from the weather (For installation on the open deck)
Other Units	Protected from the weather (Not for installation on the open deck)

# EQUIPMENT LIST

## Standard Supply

Name	Type	Code No.	Qty	Remarks	
Transceiver Unit	FS-1575T	-	1	For FS-1575	
	FS-2575T	-		For FS-2575	
	FS-5075T	-		For FS-5075	
Control Unit	FS-2575C	-	1		
Antenna Coupler	AT-1575	-	1	For FS-1575	
	AT-5075	-		For FS-2575/5075	
Installation Materials	CP05-12100	000-019-245	1	For FS-2575C, no cable, with inst. mat. CP05-12101	
	CP05-12110	000-019-301		For FS-2575C, with DSUB15-5P-L5M cable	
	CP05-12300	000-019-247	1	05S0952 *10M*	Between transceiver unit & antenna coupler.
	CP05-12310	000-019-248		05S0952 *20M*	
	CP05-12320	000-192-490		05S0952 *30M*	
	CP05-12330	000-019-250		05S0952 *40M*	
	CP05-12340	000-019-251		05S0952 *50M*	
	CP05-10800	000-057-435		05S0793 *10M*	
	CP05-10810	000-057-436		05S0793 *20M*	
	CP05-10820	000-057-453		05S0793 *30M*	
	CP05-10830	000-057-454		05S0793 *40M*	
	CP05-10840	000-057-455		05S0793 *50M*	
	CP05-12400	000-019-216	1	DSUB15-5P-L10M	Between transceiver unit & control unit.
	CP05-12410	000-019-217		DSUB15-5P-L20M	
	CP05-12420	000-019-218		DSUB15-5P-L30M	
	CP05-12430	000-019-219		DSUB15-5P-L40M	
	CP05-12440	000-019-220		DSUB15-5P-L50M	
	CP05-12001	001-135-560	1	For FS-1575T/2575T/5075T	
	CP05-12201	001-135-590	1	For AT-1575/5075	
	CP05-12901	001-175-190	1	For AT-1575	
Accessories	FP05-06600	000-019-246	1	Handset HS-2003-15, FP05-05510, FP05-05511	
Spare Parts	SP05-06300	000-020-893	1	For FS-1575,	For HK only
	SP05-06000	000-019-214	1	For FS-2575	
	SP05-06100	000-019-215	1	For FS-5075	

## Optional Equipment

Name	Type	Code No.	Remarks
Printer	PP-520	-	
Control Unit	FS-2575C	-	No. 2 Control Unit
Printer Interface	IF-8500	000-053-895	
External Loudspeaker	SEM-21Q	001-208-540	

Name	Type	Code No.	Remarks
Terminal Unit	IB-585	000-020-894	For NBDP, with bracket and keyboard (5139U or 5139U BLACK)
		000-021-652	For NBDP, no bracket, with keyboard (5139U or 5139U BLACK)
		000-038-009	For NBDP, with bracket and keyboard (SKB-E3U)
		000-038-010	For NBDP, no bracket, with keyboard (SKB-E3U)
Preamp	FAX-5 *15M*	000-011-702	w/15 m cable
	FAX-5 *1M*	000-011-703	w/1 m cable
AC-DC Power Supply Unit	PR-300	000-015-941-10	For FS-1575
	PR-850A	000-057-233	For FS-2575/5075
Matching Box	ARD-1	005-502-230	For matching, w/resistor
Antenna Junction Box	AJB1-1A	000-870-284	For matching, no resistor
Automatic Antenna Switch	AS-102	000-016-464	Automatic antenna switching
Antenna Switch	AS1-1E	000-167-029-10	Manual antenna switching
BK Interface	BK-300	000-013-305	
Flush Mount Kit	OP05-122	001-135-600	For Control Unit
Watch Receiver Kit	OP05-123	001-135-610	
Connector Set	OP05-124	001-135-620	M-P-7, 2 pcs., FMA-1
Full Duplex Kit	OP05-125	001-135-630	For FS-5075
Waterproofing Kit	OP05-126	001-148-880	For FS-2575C
	OP05-130	001-174-870	For IB-585
Capacitor Installation Kit	OP05-138	001-261-110	For AT-5075 Antenna coupler
Key Template	OP05-135	001-184-560	For Russian flag vessels (IB-585)
Hose Clamp	OP08-11	005-946-960	For Preamp FAX-5
Extension Cable Kit	OP04-2 *10M*	000-041-174	3D2V assy., w/relay connector
	OP04-2 *20M*	000-041-175	
	OP04-2 *30M*	000-041-176	
	OP04-2 *40M*	000-041-177	
	OP04-2 *50M*	000-041-178	
Whip Antenna	FAW-6R2A	000-107-921	6 m, universal bracket, copper terminal
	FAW-6R2	000-572-108	6 m, no universal bracket, copper terminal
	FAW-6RP2	000-572-109	6 m, universal bracket, M-plug
	FAW-6D	000-177-151-10	Element
		000-177-150-10	Insulator
	04S4176	001-073-340-10	2.6 m
	WH-027-8M	001-138-110-10	8 m whip antenna
	WH-027-8M02	001-138-120-10	8 m whip antenna
	WH-027-8M03	001-138-140-10	8 m whip antenna
WH-027-10M	001-139-400-10	10 m whip antenna	

## EQUIPMENT LIST

Name	Type	Code No.	Remarks
Manual Tilting Mechanism	WH-027-KD	001-139-410-10	For WH-027-8M02/10M
	WH-027-KD2	001-141-850-10	For WH-027-10M
Accessories	FP05-05700	000-010-246	Handset HS-2003-15, Bracket FP-05510, Accessories FP05-05511
Handset	HS-2003-15	000-054-223	
Bracket for Handset	FP05-05510	005-951-790	
Antenna Installation Materials	CP05-09010	005-954-180	10 m
	CP05-09020	005-964-410	25 m
	E-24	000-050-634	
	E-25	000-050-635	
	E-26	000-050-636	
	E-27	000-050-637	
Wire Rope Assy.	TM-173-D4 L1520Y8	000-176-211-10	For FS-1575
	TM-173-D4 L1670Y8	000-175-179-10	For FS-2575
	TM-173-D4 L1800Y8	000-175-178-10	For FS-5075
Coaxial Cable	RG-10/U-Y	000-159-411-10	10 m
		000-159-412-10	20 m
		000-159-413-10	30 m
		000-159-414-10	40 m
		000-159-415-10	50 m
	RG-8A/U	000-167-213-10	10 m
		000-167-214-10	20 m
		000-169-060-10	30 m
		000-169-062-10	40 m
		000-169-064-10	50 m
Cable Assy.	57FE-17JE-BC10PL3000	000-174-473-10	
Cable Assy (7-core)	05S0952 *10M*	000-758-821-10	Between transceiver unit & antenna coupler
	05S0952 *20M*	000-758-822-10	
	05S0952 *30M*	000-758-823-10	
	05S0952 *40M*	000-758-824-10	
	05S0952 *50M*	000-758-825-10	
Cable Assy (5-pair)	05S0793 *10M*	000-125-984-10	Between transceiver unit & antenna coupler w/armor
	05S0793 *20M*	000-125-986-10	
	05S0793 *30M*	000-125-987-10	
	05S0793 *40M*	000-125-988-10	
	05S0793 *50M*	000-125-989-10	
Cable Assy.	DSUB15-5P-L5M	001-146-850-10	Between transceiver unit & control unit
	DSUB15-5P-L10M	001-146-860-10	
	DSUB15-5P-L20M	001-146-870-10	
	DSUB15-5P-L30M	001-146-880-10	
	DSUB15-5P-L40M	001-146-890-10	
	DSUB15-5P-L50M	001-146-900-10	

**Note:** Whip antenna and whip antenna 1/wire can also be purchased locally. Be sure they meet the following requirements:

- STD-SSB antenna with 10 m whip antenna.
- STD-SSB antenna the 8 m whip antenna + 2 m wire.



# 1. HOW TO INSTALL THE SYSTEM

---

## 1.1 Control Unit FS-2575C

### 1.1.1 Installation location

- The location must not be near water, rain and water splash.
- Make sure the location is strong enough to hold the unit under the conditions of continued vibration and shock normally found on the boat.
- Follow the compass safe distances shown in the Safety Instructions to prevent the interference to a magnetic compass.
- Follow the recommended maintenance space shown in the outline drawing to allow the serviceman to reach the connectors at the rear of the unit.
- Direct sunlight can cause the inside of the unit to become hot. Install the unit away from direct sunlight.
- Connect the ground wire between the ground terminal and ship's earth.

### 1.1.2 How to install the unit on a desktop

A bracket is provided to install the unit on a desktop.

1. Fasten the bracket to the installation location with the self-tapping screws.
2. Loosely screw in the knobs at the sides of unit.
3. Set the unit to the bracket and tighten the knobs.



## 1. HOW TO INSTALL THE SYSTEM

### 1.1.3 How to install the unit in a console (flush mount)

The flush mount kit is required to install the Control Unit in a console.

Type: OP05-122, Code No.: 001-135-600

Name	Type	Code No.	Qty
Mounting metal	05-089-1171-0	100-299-020	2
Wing bolt	M4×40 YBSC2	000-175-263-10	4
Wing nut	M4 YBSC2	000-168-239-10	4
Hex. bolt	M6×12 SUS304	000-162-897-10	2
Spring washer	M6 SUS304	000-158-855-10	2
Protector for screw	26-005-2125-0	100-354-800-10	4

1. Make a cutout in the installation location. See the outline drawing. For the flush mount, select a flat mounting location.
2. Set the Control Unit to the cutout.
3. Attach two mounting metals (supplied) to the Control Unit with two hex bolts (M6×12, supplied) and M6 spring washers (supplied).

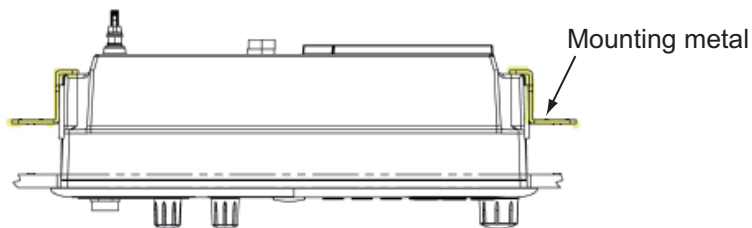

4. Screw the wing bolts and the wing nuts to the mounting metal, then attach the protectors for screws as below.

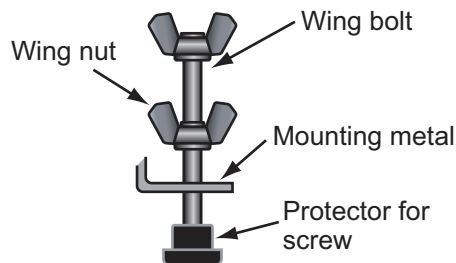

5. Fasten each wing bolt so that the protector for screw touches the back side of the mounting place.



6. Fasten the wing nuts tightly.

## 1.2 Antenna Coupler AT-1575, AT-5075

The Antenna Coupler is installed between the antenna and the Transceiver Unit, and tunes the antenna to the transmitter. The coupler must have a correct ground to function properly. The radiotelephone cannot provide its intended performance unless the ground is proper.

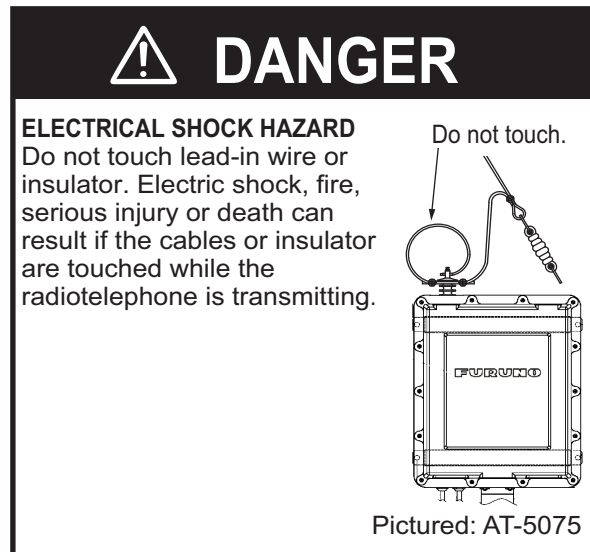

### 1.2.1 Installation location

The water-jetsproof construction of the antenna coupler permits installation either indoors or outdoors. Install the unit on a bulkhead or the overhead (indoor installation). Do not install the unit on a deck.

When selecting a location, keep in mind the following points.

#### General considerations

- Follow the compass safe distances listed in the Safety Instructions to prevent interference to a magnetic compass.
- Leave enough space around the sides of the coupler for maintenance and checking. See the outline drawing for minimum space.
- See section 1.2.2 to ground the equipment.

#### Indoor installation

- Install the unit away from GNNS equipment, radio equipment, etc. to prevent mutual interference.
- The lead-in wire should be as near to the coupler as possible.

## 1. HOW TO INSTALL THE SYSTEM

### Outdoor installation

- The coupler is water-jetsproof, but is not designed to take a continual soaking.
- Install the coupler close to the antenna base.
- Keep wires as short as possible and keep the wires away from any grounded conductors such as lifelines, mast shrouds, or fittings.
- Locate the insulator away from funnels, etc.

### 1.2.2 Ground

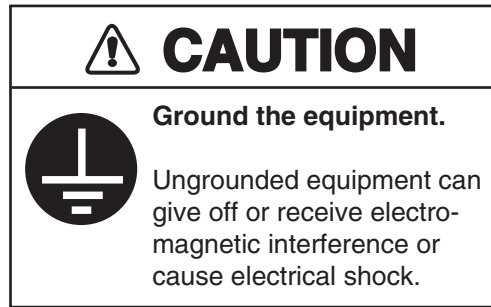

The ground connection must have the lowest possible RF-impedance. Losses in the ground connection reduce the communication distance.

Make the ground connection to the Antenna Coupler with a copper strap, constructed as shown below. **For vessels with conducting hulls**, make the width at least 60 mm and the length not more than one meter. **For FRP vessels**, make the width at least 60 mm and the length not more than five meters.

**Note:** Coat the copper strap between the ground plate and ground terminal of the antenna coupler with marine paint to prevent corrosion.

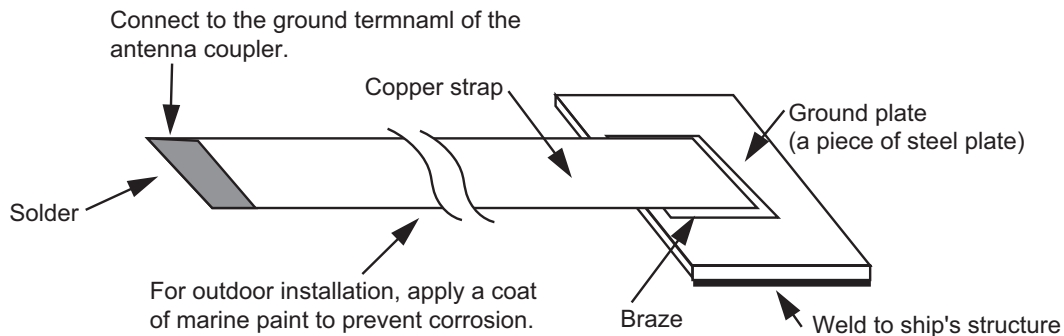

Coat the junction where the copper strap connects to the ground terminal of the antenna coupler with silicone sealant.

It is recommended to add a supplemental ground wire (local supply, more than 14 sq.) and fasten it to the ground terminal of the antenna coupler as shown below.

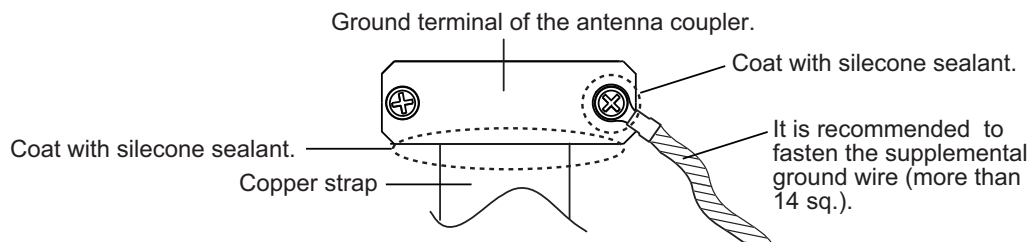

### 1.2.3 Installation procedure

#### Outdoor installation

Fasten the Antenna Coupler to a bulkhead of the bridge, mast, handrail, etc., with the M6 bolts (local supply).

For installation on the mast, see section 1.5 to select a location. Weld suitable mounting fixtures (local supply) to the mast and bolt the coupler there.

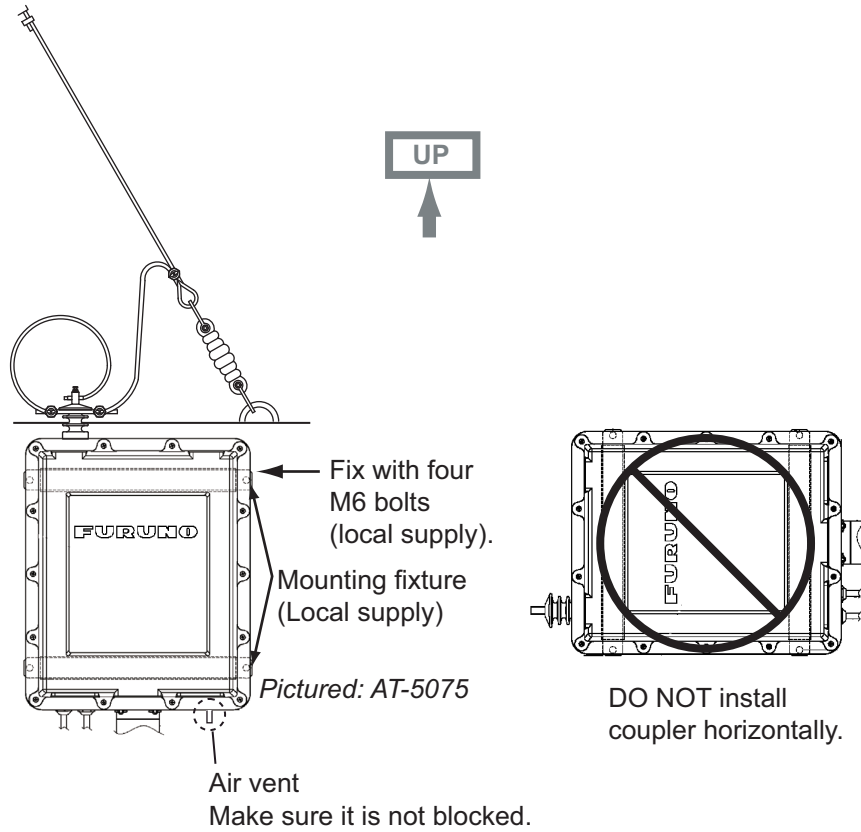

#### Indoor installation

Fasten the Antenna Coupler to a bulkhead on the bridge or the overhead. Select a location where the distance between the lead-in insulator and the coupler is as short as possible.

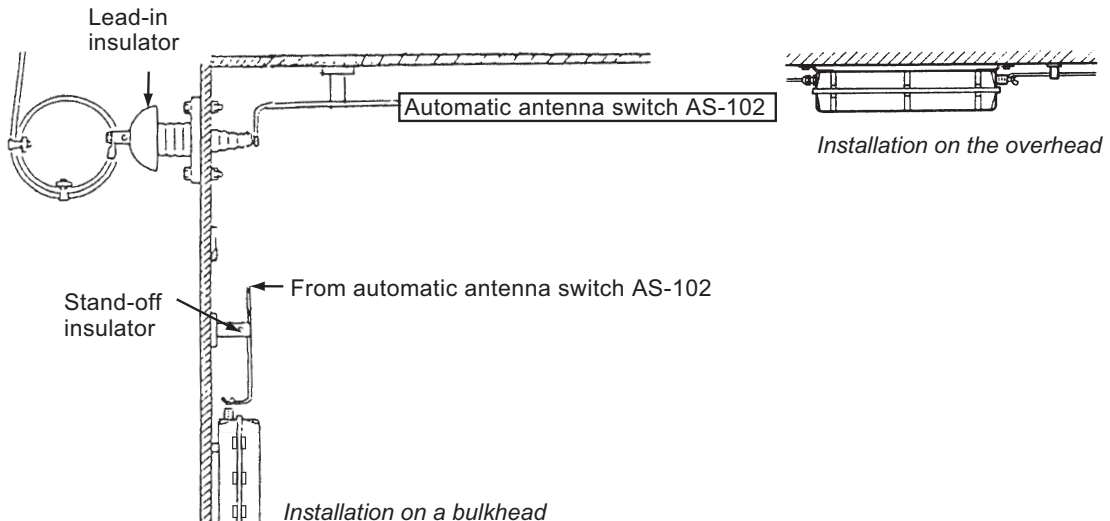

### 1.3 Transceiver Unit FS-1575T, FS-2575T, FS-5075T

Select a location that meets these conditions:

- Select a location which provides good ventilation.
- The location must be clean and dry.
- Make sure the location can hold the unit under the conditions of continued vibration and shock normally found on the boat. If necessary, increase the strength the installation location.
- Follow the compass safety distance shown in the Safety Instructions to prevent the interference to a magnetic compass.
- Follow the recommended service space shown in the outline drawing to provide space for maintenance and checking.
- Install the unit away from direct sunlight to prevent overheating.

Fasten the unit with 6×30 self-tapping screws on a bulkhead. Refer to the outline drawing for installation dimensions.

### 1.4 Handset HS-2003

Unfasten six screws to remove the bracket cover. Fasten the bracket to the location with two self-tapping screws 4x16 (supplied).

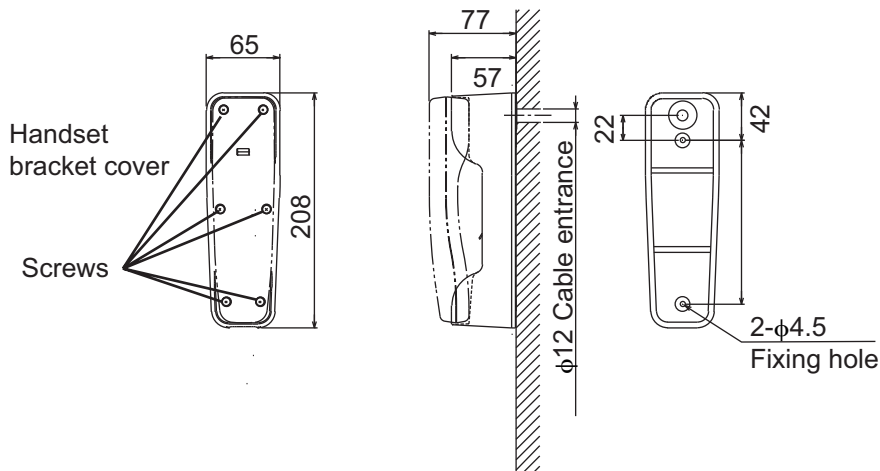

## 1.5 Antenna

The antenna plays the most important role in radio communication. If it cannot receive or transmit due to improper installation, even the most sophisticated transceiver will be useless. After setting up the equipment, confirm that the antenna can tune all frequencies.

### Types of antennas

- The most commonly used antenna is a whip antenna. The recommended minimum total length is 10 meters. For an 8 m whip antenna, secure it with a lead-in wire of at least 2 m in length, as shown in the illustration below.
- A long wire antenna can also be used. The total length must be between 10 and 18 meters.

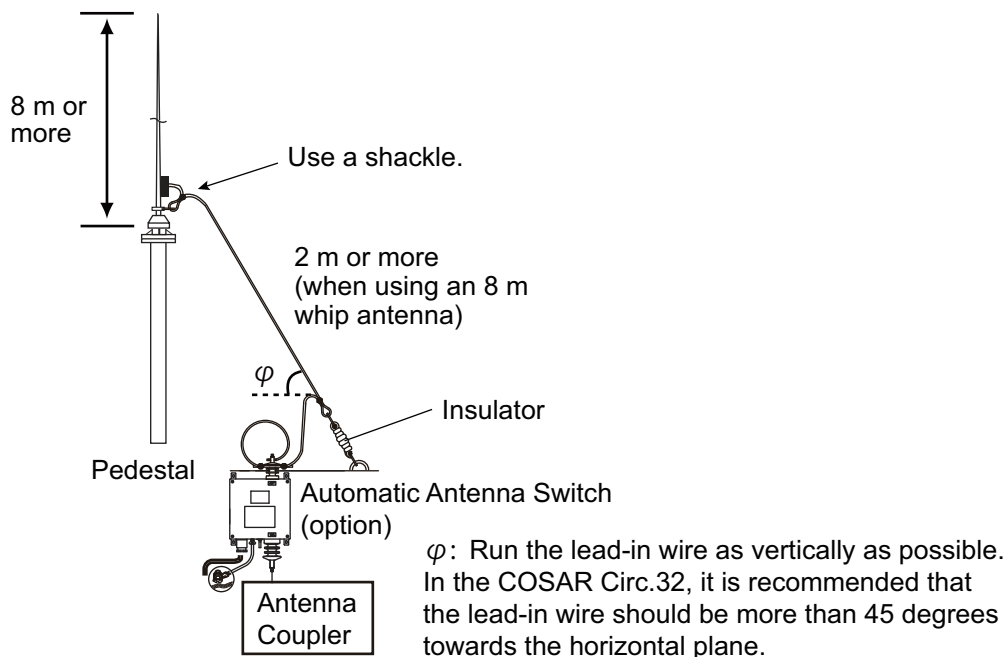

### General requirements

- Separate the TX antenna as far as possible from stays, metallic objects, and direction finder antenna.
- The distance to an Inmarsat antenna must be more than five meters.
- The RX antenna (required for duplex communications) should be separated at least five meters from the TX antenna.
- Use a wave-type insulator to connect to the coupler (or antenna switch) and leave some slack in the feed-in wire, to prevent direct stress to the coupler.
- Install an antenna junction box (AJB1-1A) or matching box (ARD-1) at the base of the antenna.
- Locate the insulator away from funnels, etc.
- The length of the vertical portion should be longer than four meters. Run as vertically as possible and within 10 degrees toward the vertical plane.
- See section 2.1.2 to connect the antenna wire with the ANT terminal of the antenna coupler (or automatic antenna switch).
- Keep in mind antenna bending by wind and install away from any conductor.

## 1. HOW TO INSTALL THE SYSTEM

### **Installation requirements for whip antenna**

- The installation arrangement of the antenna or pedestal must be constructed to withstand the strain from swaying and vibration.
- Locate the antenna in an elevated position on the ship and at least one meter away from conductive structures.
- Run the down lead from the base of the antenna to the coupler as vertically as possible. In the COSAR Circ.32, it is recommended that the down lead should be more than 45 degrees towards the horizontal plane.
- For indoor installation, use a lead-in insulator (FURUNO type: YA-256) to make the connection. If necessary, use a high quality antenna switch and stand-off insulator.
- It is recommended to construct an enclosure around the whip antenna to prevent contact with the antenna. Also, post a weather resistant "DANGER HIGH VOLTAGE" sign on the enclosure.

### **RX antenna**

An RX antenna is required for duplex communications (FS-5075).

## 1.6 How to Install Optional Equipment

### 1.6.1 Preamp Unit FAX-5

The preamp unit can be mounted two ways as shown below. For detailed installation procedure, see the outline drawing for the preamp unit.

- Screw onto a pipe ( $\phi 27.2$  mm) with Whitworth fine screw threads (W25-14) whose length is 50 mm.  
**Note:** The mast should not be longer than 1.5 m (5 feet) to prevent undue flexing in heavy winds.
- Fix to a mast ( $\phi 35$  to 90 mm), using stainless steel hose clamps (optional supply).

### 1.6.2 Printer PP-520

Refer to the outline drawing at the end of this manual for mounting dimensions and recommended maintenance space. Follow the compass safety distance shown in the Safety Instructions to prevent interference to a magnetic compass. Connect the interconnection cable between the printer and the Control Unit (or Printer Interface). For how to load paper and set ribbon cassette, refer to the Operator's Manual of the printer.

Set the fixtures (left/right) onto the printer. Fasten them with four self-tapping screws ( $\phi \times 20$ ).

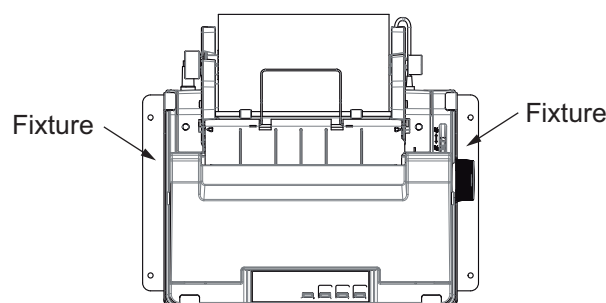



### **1.6.3 Printer Interface IF-8500**

Refer to the outline drawing at the end of this manual for mounting dimensions and recommended maintenance space. Follow the compass safety distance shown in the Safety Instructions to prevent interference to a magnetic compass. Fasten the Printer Interface with self-tapping screws (local supply) to desktop or bulkhead.

### **1.6.4 External Loudspeaker SEM-21Q**

The external loudspeaker can be installed on a tabletop, the overhead or bulkhead. Follow the compass safety distance shown in the Safety Instructions to prevent interference to a magnetic compass. See the outline drawing at the back of this manual for mounting dimensions and recommended maintenance space. When selecting the location, keep in mind the length of the connection cable (2.8 m). Fasten the loudspeaker to the mounting location with the self-tapping screws (supplied).

### **1.6.5 AC-DC Power Supply PR-850A, PR-300**

Select a location that satisfies the following conditions:

- The location provides good ventilation.
- The location is clean and dry.
- Make sure the location is strong enough to support the unit under the conditions of continued vibration and shock normally encountered on the boat.
- Follow the compass safety distance in the Safety Instructions to prevent interference to a magnetic compass.
- The location provides the maintenance space shown in the outline drawing.

## 1. HOW TO INSTALL THE SYSTEM

### 1.6.6 Terminal Unit IB-585

Install the Terminal Unit on a desktop. Select a location that meets the following conditions.

- The temperature and humidity in the location must be stable and moderate.
- Keep the unit away from the high-power radiotelephone and its feeder wire so that RFI (Radio Frequency Interference) is minimum.
- Follow the compass safety distance shown in the Safety Instructions to prevent the interference to a magnetic compass.
- Follow the recommended maintenance space shown in the outline drawing to facilitate maintenance and checking.

#### **How to install the terminal unit**

1. Fix the bracket to the location with four self-tapping screws (supplied).
2. Loosely screw in two knobs in the terminal unit.
3. Set the terminal unit to the bracket and tighten the knobs.

#### **How to install the keyboard**

**<For 5139U or 5139U BLACK>**

1. Attach the function key label to the keyboard as shown below.

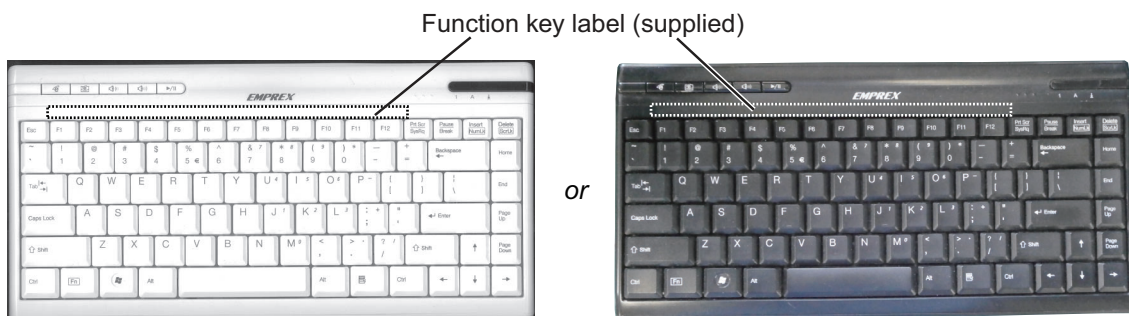

2. Stick the smaller velcro tape (Fastener, 4 pcs., supplied with the optional kit) to the four corners of the rear of the keyboard.
3. Fit the larger velcro tape (Fastener, 4 pcs., supplied with the optional kit) to the smaller tape.
4. Remove the protective film from the larger velcro tape.
5. Fit the keyboard at the installation location.

**<For SKB-E3U>**

1. Stick the NBDP function key stickers (supplied with the optional kit) to their respective keys (F1 to F10).
2. Referring to the following steps, fit the static electricity prevention sheet (included as optional kit) to the keyboard, then fix the keyboard at the installation location using the double-sided tape (Tape V/H, supplied with the optional kit).
  - 1) Remove the protective film from one side of the supplied double-sided tape, then stick the tape to the 4 edges of the rear of the keyboard.

## 1. HOW TO INSTALL THE SYSTEM

- 2) Remove the protective film on both sides of the sheet, then fit the sheet to the keyboard.

**Note:** The sheet is extremely thin and should be handled with care.

- 3) Remove the protective film from the double-sided tape on the rear of the keyboard, then fix the sheet to the tape.

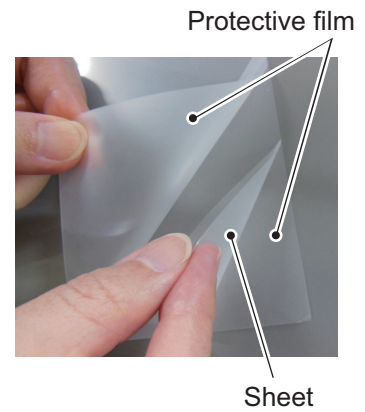

3. Stick the smaller velcro tape (Fastener, 5 pcs., supplied with the optional kit) to the four corners of the rear of the keyboard and to the EMI core.
4. Fit the larger velcro tape (Fastener, 5 pcs., supplied with the optional kit) to the smaller tape.
5. Remove the protective film from the larger velcro tape.
6. Fit the keyboard at the installation location.
7. Depending on the installation location and environment, move and then fit the EMI cores as required.

The following points should be observed when moving the EMI cores:

- Do not remove or disconnect the USB cable.
- Do not apply undue stress or weight to the base of the cable connection on the keyboard.
- The EMI core must not be suspended freely as this puts strain on the cable.
- Re-wrap the cable around the EMI core a total of 6 times. The cable should pass through the EMI core a total of 7 times.

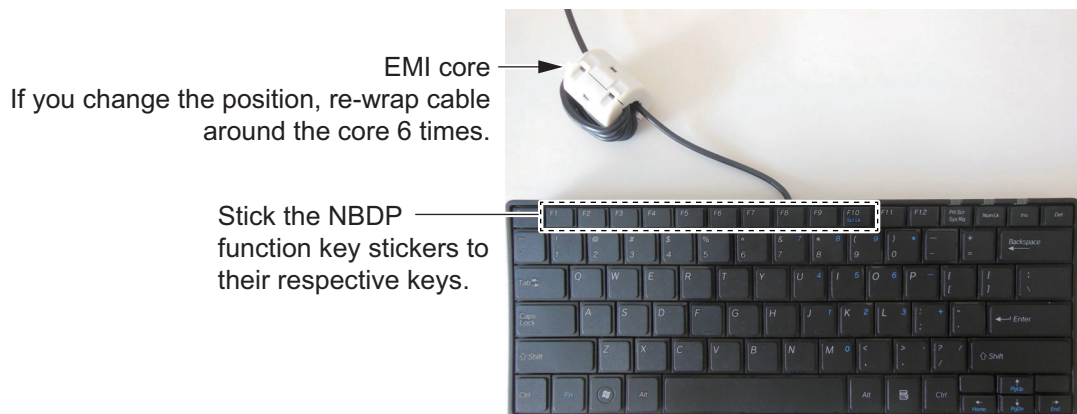

## 1. HOW TO INSTALL THE SYSTEM

### 1.6.7 Automatic Antenna Switch AS-102

The Automatic Antenna Switch AS-102 allows you to connect the antenna to ground remotely with an external switch when there is a possibility of lightning, or the antenna must be grounded to meet with local regulations when returning to a harbor. Install the unit between the antenna and the Antenna Coupler. When you do not use this unit, the antenna is connected to ground in the Antenna Coupler by turning off the radio-telephone.

Fasten the unit on a bulkhead with four 5×20 self-tapping screws (supplied), or bolts and nuts. Coat the ANT, TX and ground terminal with silicone sealant. An external switch can be installed to turn off the antenna manually. See the interconnection diagram.



Fixing hole (4 pcs.)  
Fasten unit with four self-tapping screws (5x20, supplied).

### 1.6.8 WR2 Board

The WR2 Board (05P0847B) enables reception of DSC routine frequencies while using the SSB radiotelephone connection. See section 3.4.6 for antenna configurations.

*Watch Receiver Kit (Type: OP05-123, Code No.: 001-135-610)*

Name	Type	Code No.	Qty
WR2 Board	05P0847B(LF)	001-137-100	1
Binding head screw	M3×6 SUS304	000-163-485-10	6
Mini-pin assy.	L-200 07S0046	000-165-847-10	1
Connector assy.	MJ145-TMP-1.5D-L520	000-175-320-10	1
Shield case	03-161-1011-0	100-302-730-10	2

1. The Preamp Unit FAX-5 requires 12 VDC power. Set the jumper block J3 on the WR2 Board to the ACTIVE position to supply power to the unit.

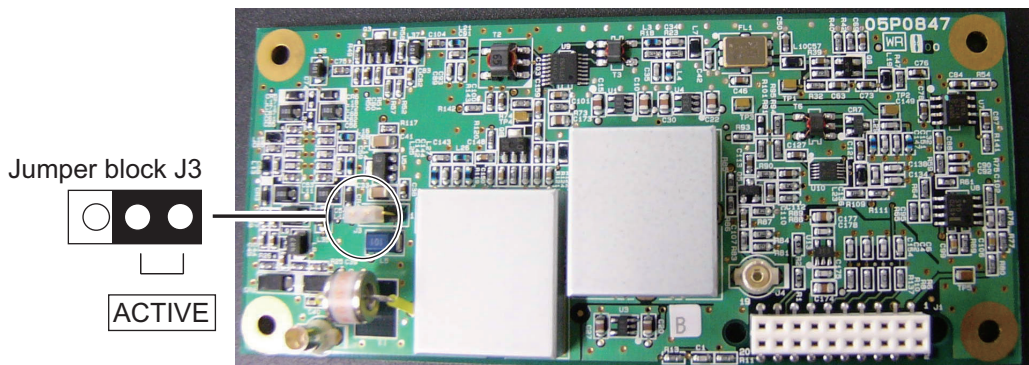

2. Open both the Transceiver Unit and the shield cover.
3. Fasten the WR2 Board with four screws (supplied) at the location shown below.

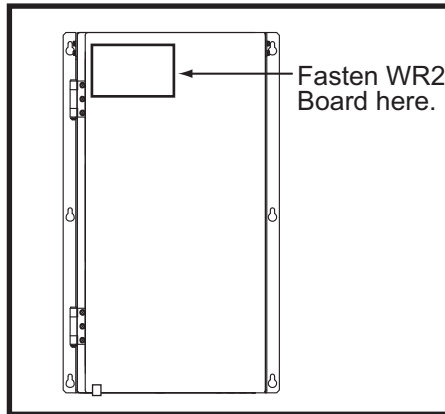

## 1. HOW TO INSTALL THE SYSTEM

4. Make the following connections between the WR2 Board / ANT WR2 / RX-FIL Board, with the Mini-pin assy. (supplied with this kit) and the connector assy. (supplied with this kit).

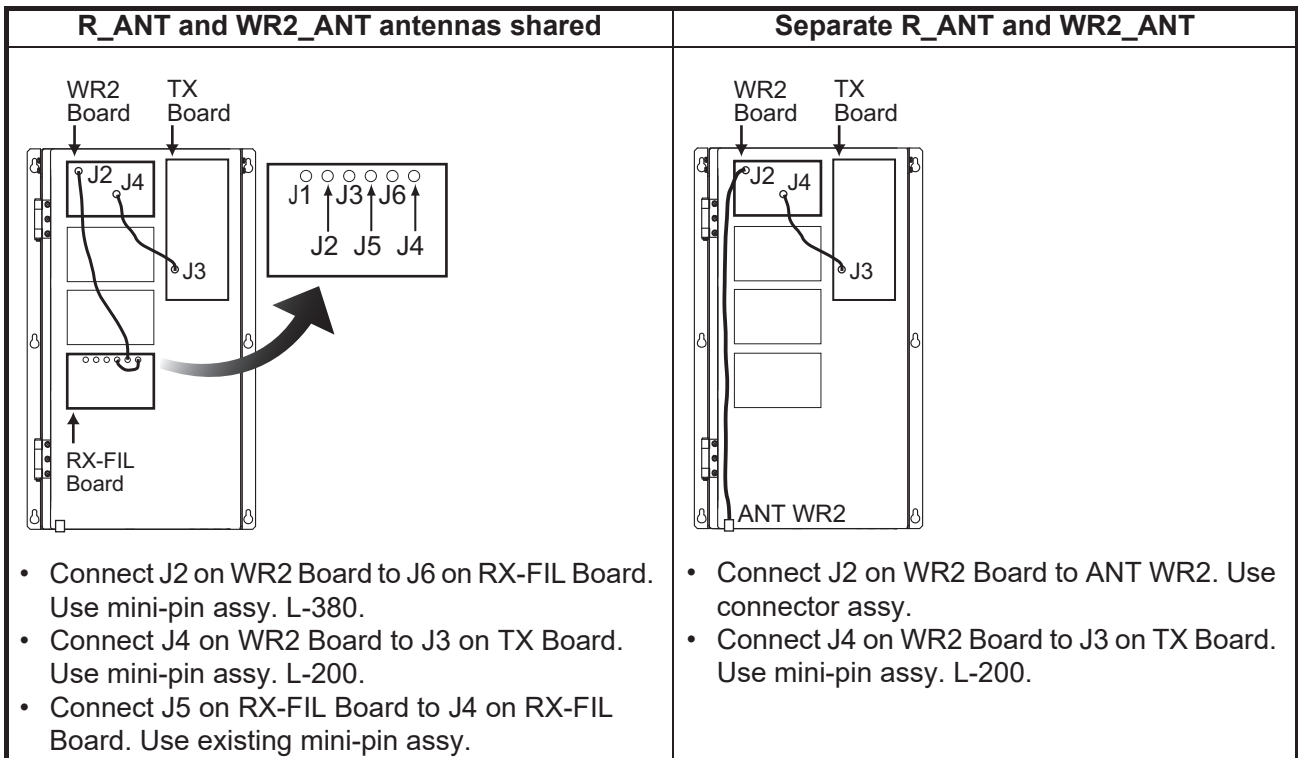

5. **For FS-2575/5075, if a divider is not connected**, fasten the connector assy. with the locking saddle next to the WR2 Board.
6. Close the shield cover and the Transceiver Unit.
7. **For R\_ANT and WR2\_ANT shared**, open the [RT SETUP] menu (see section 3.3.4), select [SETUP] and set [DIVIDER] to [ON].

### 1.6.9 DUP-FIL Board (FS-5075 only)

The DUP-FIL Board (05P0863) installs above the RX-FIL Board (05P0862A) and gives the FS-5075 full duplex capability. Parts Name: Full Duplex Kit, Type No. OP05-125, Code No. 001-135-630

Name	Type	Code No.	Qty
DUP-FIL Board	05P0863(LF)	001-137-900	1
Mini-pin assy.	L-80	000-165-835-10	3
Spacer	SQ-15	000-159-299-10	4

1. Open both the Transceiver Unit and the shield cover.
2. Unfasten the four pcb mounting screws from the RX-FIL Board. See the illustration below for the location of the Board.

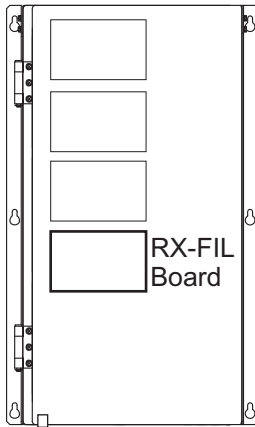

3. Screw in four spacers (supplied) in the pcb mounting screw holes for the RX-FIL Board.
4. Set the DUP-FIL Board on top of the spacers then fasten the Board to the spacers with the screws removed at step 2.
5. Make the connections shown below between the DUP-FIL Board and the RX-FIL Board, using the mini-pin assemblies (supplied).

DUP-FIL Board		RX-FIL Board
J1	←→	J3
J2	←→	J4
J3	←→	J8

6. Close the shield cover and the Transceiver Unit.



1. HOW TO INSTALL THE SYSTEM

**1.6.10 Waterproofing kit for the Control Unit**

The waterproofing kit OP-126 (Code No. 001-148-880) protects the connectors and jacks on the control unit from water ingress, to waterproofing standard IP22.



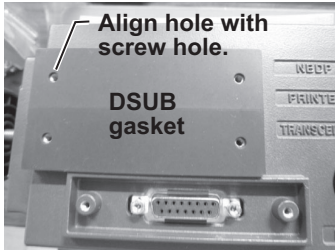
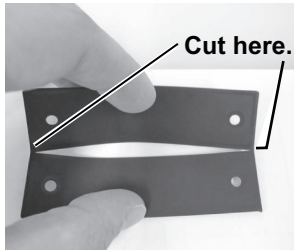
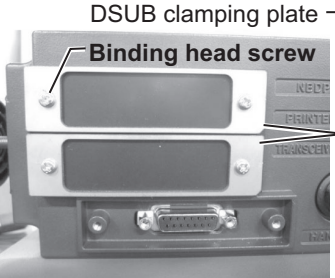
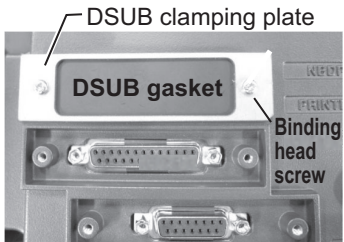



Name	Type	Code No.	Qty
DSUB gasket	05-106-5571-1	100-365-871-10	1
SPJACK gasket	05-106-5572-0	100-365-880-10	1
DSUB clamping plate	05-106-5604-1	100-365-931-10	3
SPJACK clamping plate	05-106-5606-0	100-365-950-10	1
DSUB boot	05-106-5603-0	100-365-920-10	3
SPJACK boot	05-106-5605-0	100-365-940-10	1
Cable tie	CV-125N	000-172-164-10	4
Binding head screw	M3×8 SUS304	000-162-665-10	8

**How to protect unused connector(s), speaker jack**

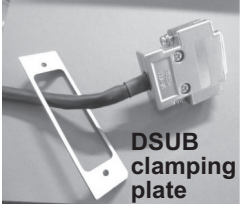
UNUSED CONNECTOR(S)	
<p>Two connectors</p> <p>1) Put the DSUB gasket on the unused connectors and align its holes with the screw holes on the connectors. Leave the plastic caps on the connectors.</p>  <p>Align hole with screw hole. DSUB gasket</p>	<p>One connector</p> <p>1) Cut the DSUB gasket at the two places shown, in the direction of the slit on the gasket.</p>  <p>Cut here.</p>
<p>2) Put the DSUB clamping plates on the DSUB gasket and fasten them with four binding head screws (torque: 0.5Nm).</p>  <p>DSUB clamping plate Binding head screw</p>	<p>2) Put the DSUB gasket and DSUB clamping plate on the unused connector. Fasten them with two binding head screws (torque: 0.5Nm).</p>  <p>DSUB clamping plate DSUB gasket Binding head screw</p>
UNUSED SPEAKER JACK	
<p>1) Put the SPJACK gasket on the speaker jack location. Be sure the gasket seats in the recess.</p>  <p>SPEAKER SPJACK gasket</p>	<p>2) Put the SPJACK clamping plate on the SPJACK gasket, with the straight edge on the plate down. Fasten the plate with two binding head screws (torque: 0.5Nm).</p>  <p>SPEAKER SPJACK clamping plate</p>

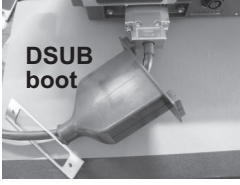

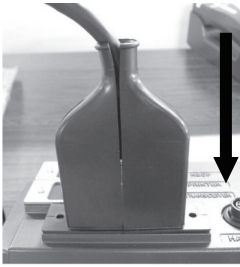
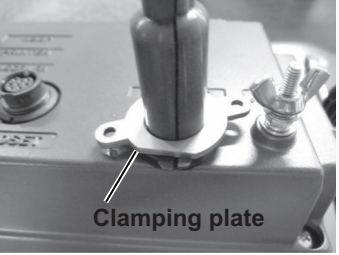
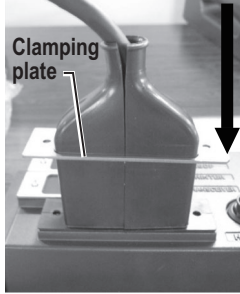
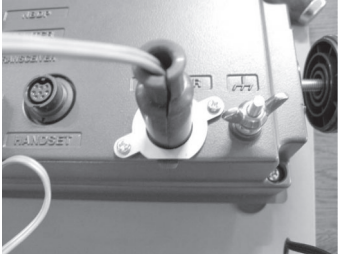
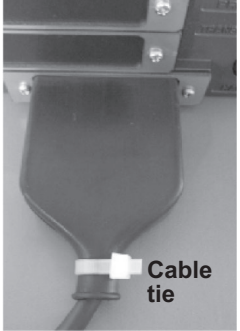
**How to protect connector, speaker jack in use**

CONNECTOR IN USE	SPEAKER JACK IN USE
<p>1) Pass the cable through the DSUB clamping plate.</p>  <p>DSUB clamping plate</p>	<p>1) Pass the cable through the SPJACK clamping plate. Note the orientation of the straight edge on the clamping plate.</p>  <p>SPJACK clamping plate</p>
<p>2) Connect the cable to the control unit. Put the DSUB boot on the cable, with the slit on the boot down.</p>  <p>DSUB boot</p>	<p>2) Connect the cable to the speaker jack. Put the SPJACK boot on the cable, with the slit on the boot down.</p>  <p>SPJACK boot</p>
<p>3) Slide the DSUB boot downward until it contacts the control unit.</p> 	<p>3) Slide the clamping plate downward until it contacts the boot, with the straight edge on the plate down. Be sure there is no gap between the plate and the boot.</p>  <p>Clamping plate</p>
<p>4) Slide the clamping plate downward until it contacts the boot. Be sure there is no gap between the plate and the boot.</p>  <p>Clamping plate</p>	<p>4) Fasten the plate with two binding head screws (torque: 0.5Nm).</p> 
<p>5) Fasten the plate with two binding head screws. (torque: 0.5Nm). Fasten the boot to the cable with a cable tie.</p>  <p>Cable tie</p>	<p>5) Fasten the boot to the cable with a cable tie.</p>  <p>Cable tie</p>

## 1. HOW TO INSTALL THE SYSTEM

This page is intentionally left blank.

## 2. WIRING

The illustration on this page and the next two pages show general connections between the Antenna Coupler, Transceiver Unit, Control Unit and external equipment. For detailed information, see the interconnection diagram. Many of the cables mentioned are JIS (Japan Industry Standard) cables. If not available locally, use the equivalent. See the cable guide in the Appendix for how to select equivalent cables.

### FS-1575

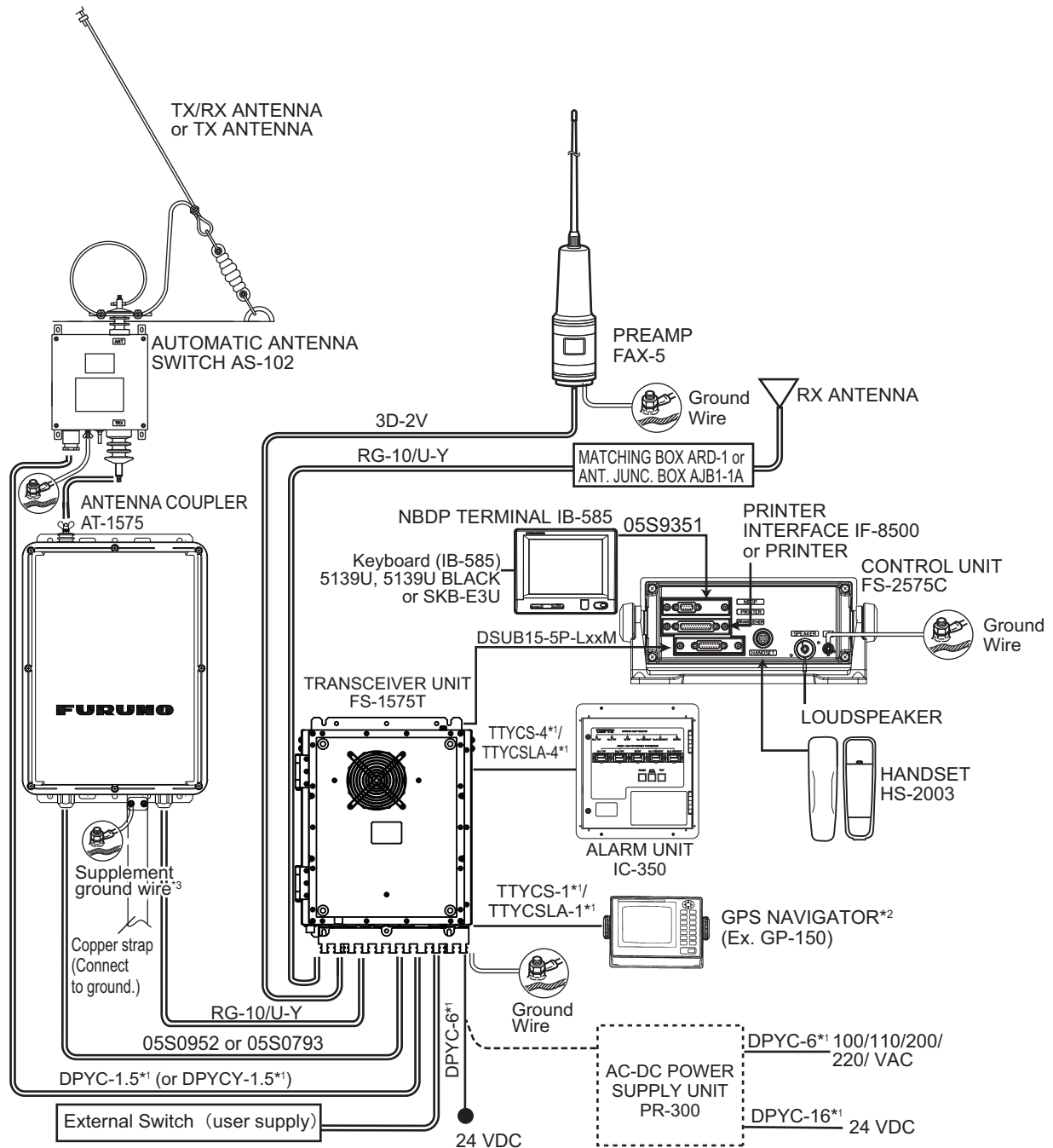

\*1: JIS cable. See Appendix for equivalent cable.

\*2: Connect the GPS navigator to the GNSS port of the transceiver unit. When you set the AMS mode to [AlertIF1] or [AlertIF2], connect an AMS or sensor adaptor that can output GPS information to the GNSS port.

\*3: It is recommended to add a supplement ground wire (local supply, more than 14 sq.) and fasten it to the ground terminal of the antenna coupler.

2. WIRING

**FS-2575**

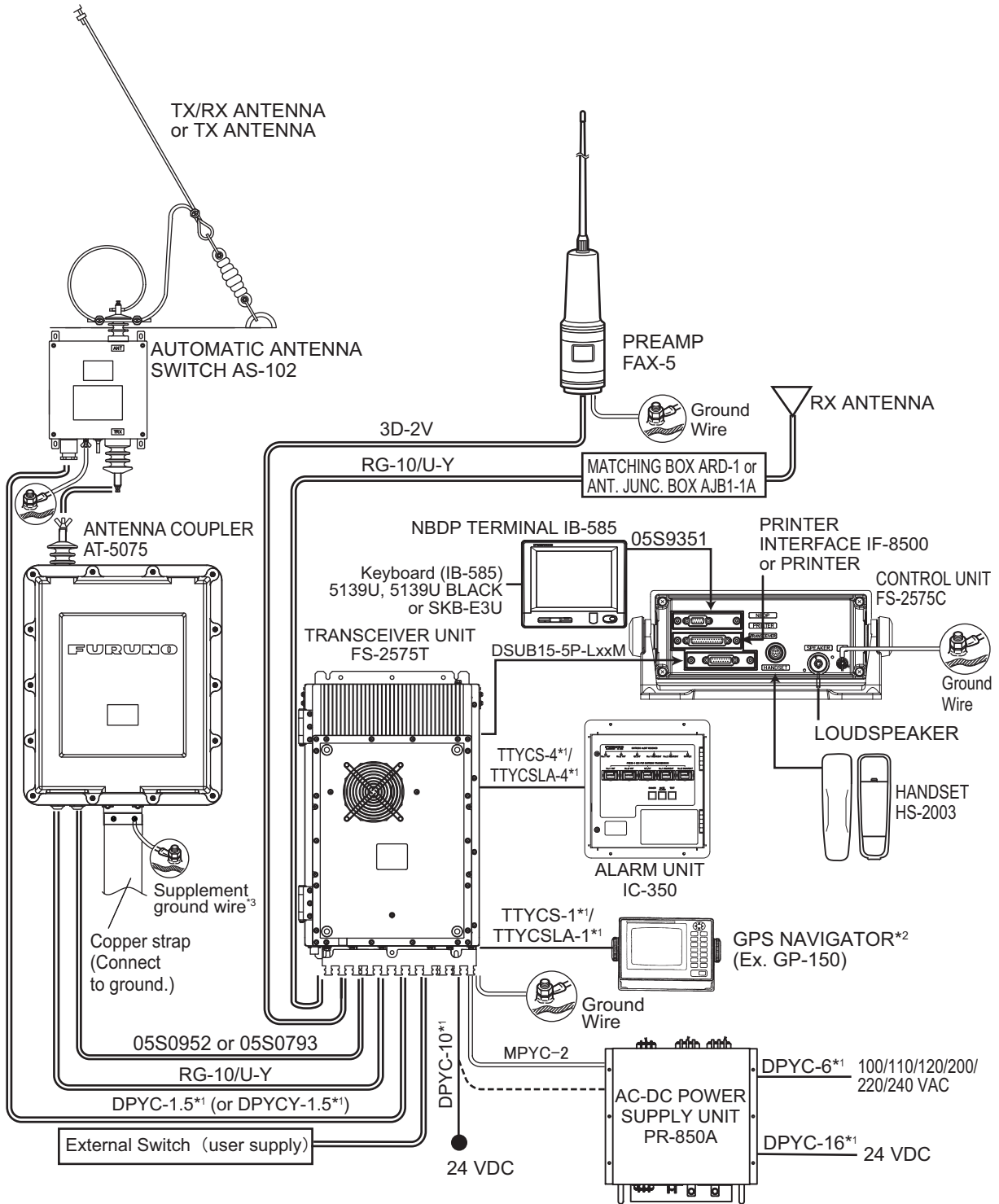

\*1: JIS cable. See Appendix for equivalent cable.

\*2: Connect the GPS navigator to the GNSS port of the transceiver unit. When you set the AMS mode to [AlertIF1] or [AlertIF2], connect an AMS or sensor adaptor that can output GPS information to the GNSS port.

\*3: It is recommended to add a supplement ground wire (local supply, more than 14 sq.) and fasten it to the ground terminal of the antenna coupler.

**FS-5075**

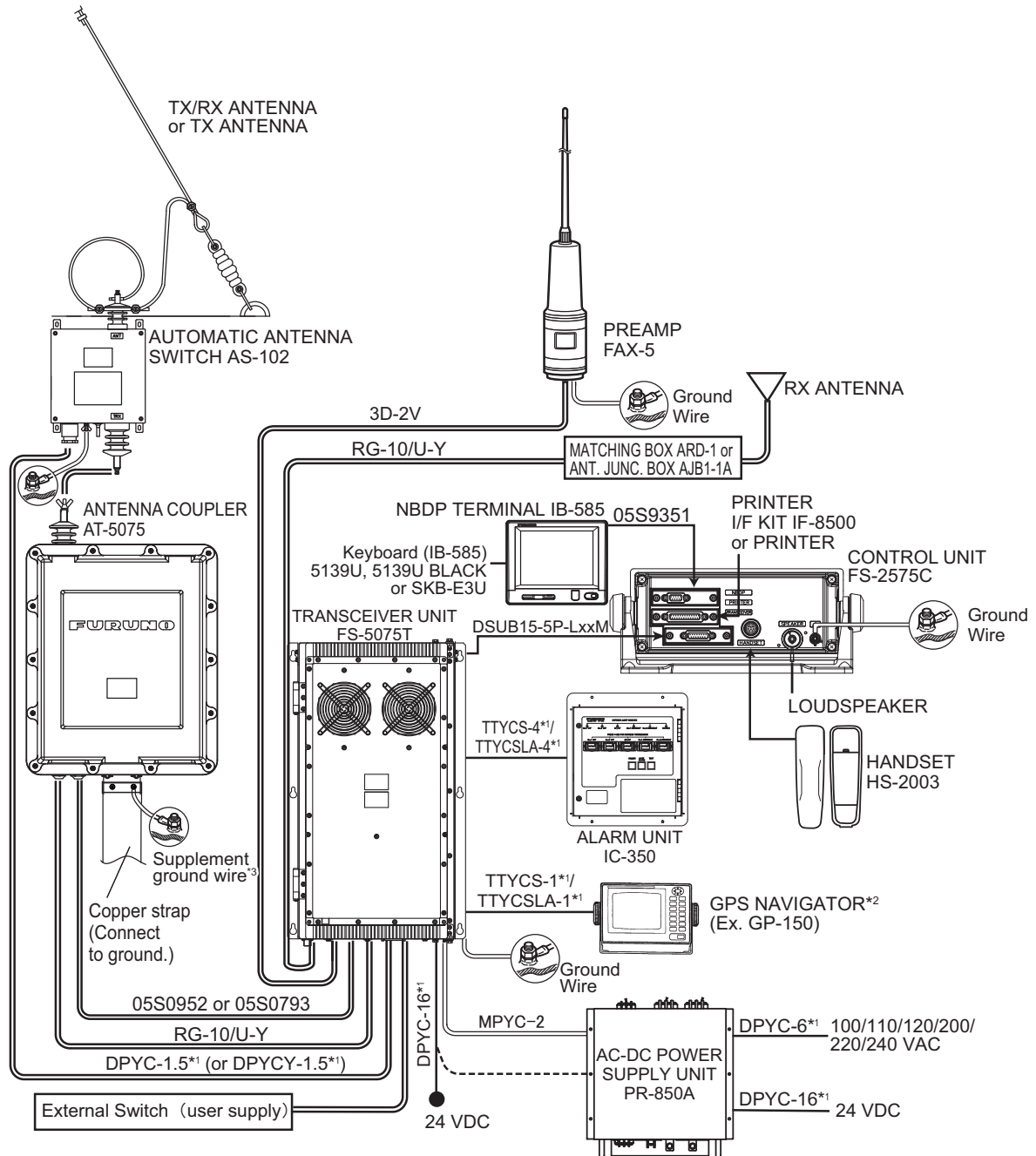

\*1: JIS cable. See Appendix for equivalent cable.

\*2: Connect the GPS navigator to the GNSS port of the transceiver unit.  
When you set the AMS mode to [AlertIF1] or [AlertIF2], connect an AMS or sensor adaptor that can output GPS information to the GNSS port.

\*3: It is recommended to add a supplement ground wire (local supply, more than 14 sq.) and fasten it to the ground terminal of the antenna coupler.

## 2.1 Antenna Coupler

**Note:** The T/R antenna is automatically connected to ground when the power is turned off.

### 2.1.1 General connections

Three cables connect to the Antenna Coupler: the signal cable (7-core cable (05S0952) or 5P cable (05S0793)), coaxial cable from the Transceiver Unit, and the antenna wire.

For the connection of the antenna wire, use an insulator so as not to put stress on the connector at the ANT terminal of the Antenna Coupler.

**Note:** For the 5P cable (05S0793), cut off the armor to pass the cable through the cable entrance on the Antenna Coupler, and then wrap vinyl tape around the end of armor.

1. Open the cover of the Antenna Coupler.
2. Unscrew the nut for the signal cable and coaxial cable.
3. Remove the following from each cable:
  - AT-1575:** Gasket
  - AT-5075:** Two washers and gasket
4. Do one of the following:
  - AT-1575:** Pass the nut and gasket onto the cable as shown below.
  - AT-5075:** Pass the nut, two washers and gasket onto the cable in the order shown below.

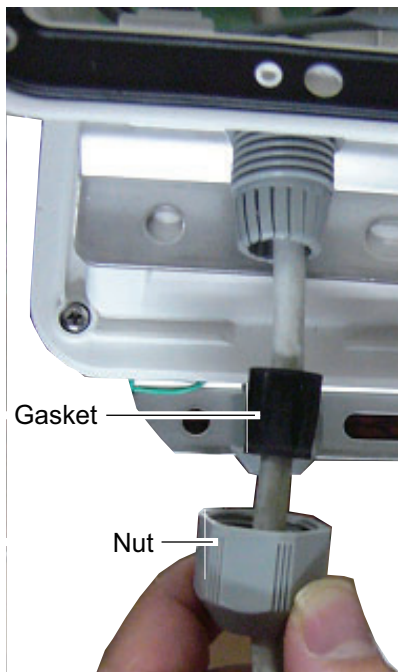

*Antenna Coupler AT-1575*

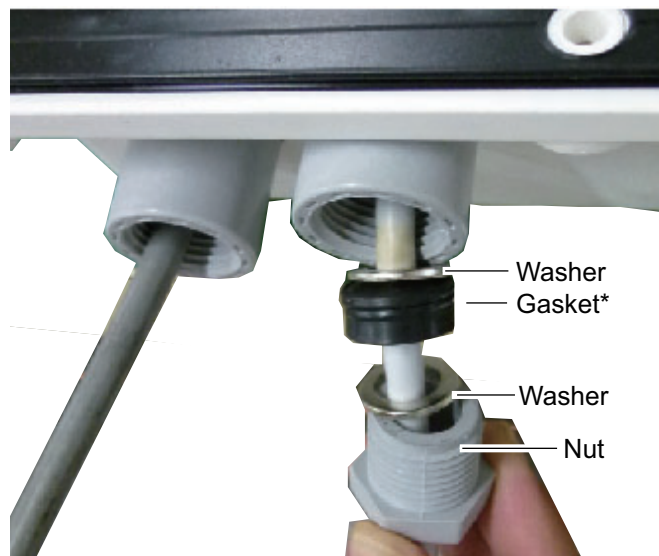

\* Replace this gasket with one supplied with accessories if diameter of coax cable is larger than the one supplied.

*Antenna Coupler AT-5075*

*Antenna Coupler AT-1575, AT-5075, bottom front view*

5. Fabricate the signal cable and the coaxial cable as shown below.

**\* How to process the shield:**

Wrap the shield with vinyl tape, fasten crimp-on lug to vinyl wire, fasten crimp-on lug to the "E" terminal. Cut unused wires and wrap them with vinyl tape.

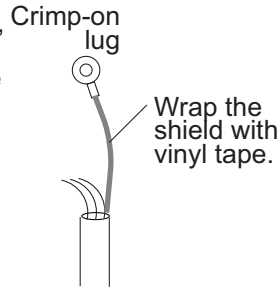

**\*\* How to fabricate the coaxial cable:**

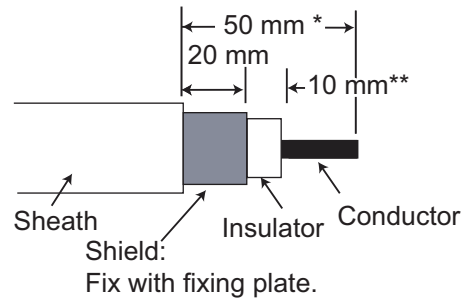

\*: 65mm if the coupler type is AT-5075.

\*\* : 15mm if the coupler type is AT-5075.

6. Connect the signal cable and the coaxial cable to the board as shown below.

**AT-1575(In the case of 05P0883-00)**

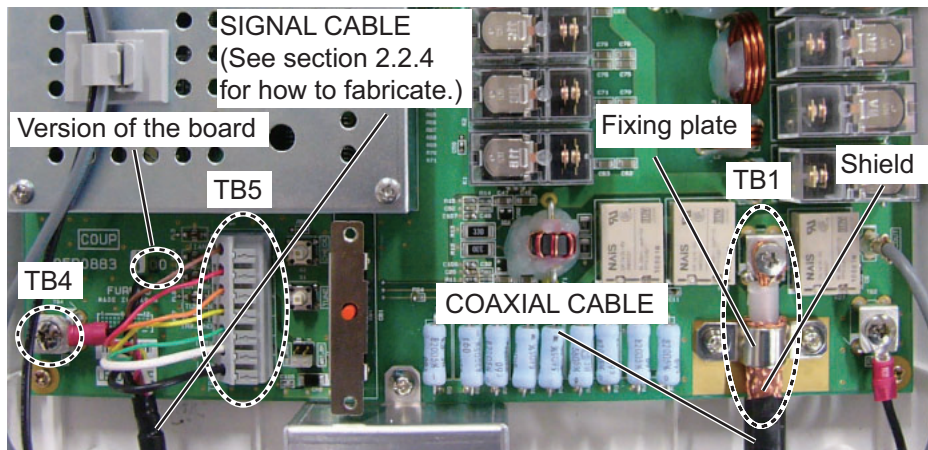

Antenna Coupler AT-1575, inside view (Old type board,05P0883-00)

a) Connect the wires from the signal cable to TB5, as shown in the diagram below.

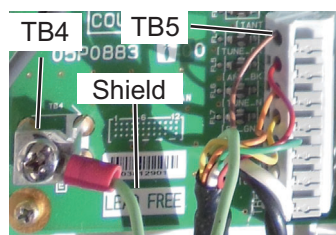

No. (Color): Name

- 1 (BRN): ANT
- 2 (RED): TUNE\_OK
- 3 (ORN): ANT\_BK
- 4 (YEL): TUNE\_N
- 5 (GRN): RX\_GND
- 6 (WHT): 15V
- 7 (BRK): GND

b) Connect the shield wire from the signal cable to TB4.

c) Unfasten the screws to remove the fixing plate, then connect the coaxial cable.

d) Secure the shield of the coaxial cable with the fixing plate and screws.

**AT-1575(In the case of 05P0883-22)**

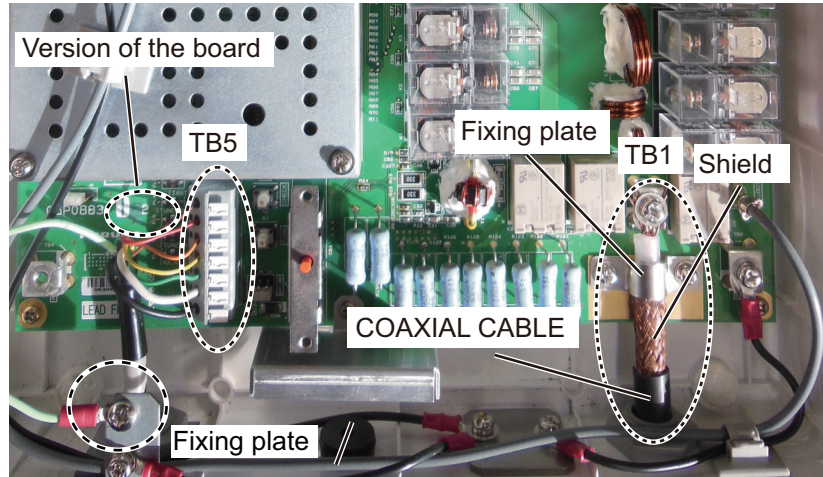

*Antenna Coupler AT-1575, inside view (New type board,05P0883-22)*

- a) Connect the wires from the signal cable to TB5, as shown in the diagram below.

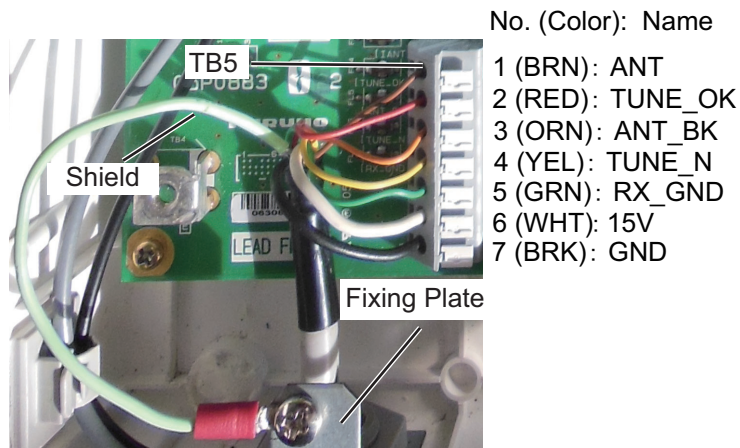

- b) Connect the shield wire from the signal cable to TB4.
- c) Unfasten the screws to remove the fixing plate, then connect the coaxial cable.
- d) Secure the shield of the coaxial cable with the fixing plate and screws.



**AT-5075**

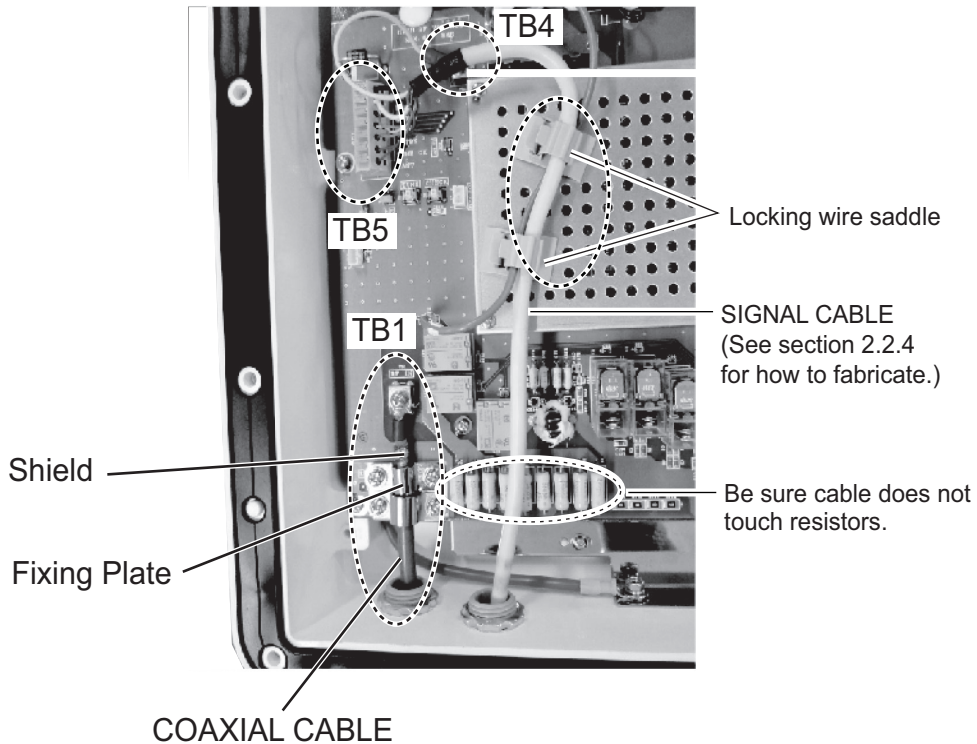

*Antenna Coupler AT-5075, inside view*

- a) Pass the signal cable into the transceiver unit, taking care that the cable does not touch the resistors.
- b) Connect the wires from the signal cable to TB5, as shown in the figure below.

No. (Color): Name

- 7 (BRK): GND
- 6 (WHT): 15V
- 5 (GRN): RX\_GND
- 4 (YEL): TUNE\_N
- 3 (ORN): ANT\_BK
- 2 (RED): TUNE\_OK
- 1 (BRN): ANT

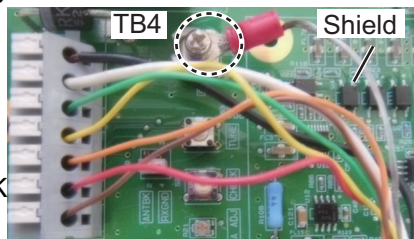

- c) Connect the shield wire from the signal cable to TB4.
- d) Unfasten the screws to remove the fixing plate, then connect the coaxial cable.
- e) Secure the shield of coaxial cable with the fixing plate and screws.

## 2. WIRING

7. Check that the gasket is engaged to the posts on the casing then close the cover.  
(Pictured: AT-5075)

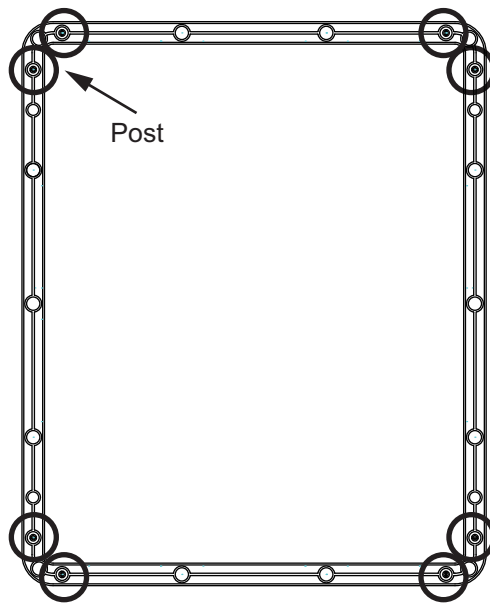

### 2.1.2 Connections for outside installation

For outside installation, arrange the antenna wire as shown below. The optional antenna materials shown below are necessary.

Name	Type	Code No.	Remarks
Antenna materials	CP05-09010	005-954-180	w/10 m antenna cable
	CP05-09020	005-964-410	w/25 m antenna cable

1. Make a loop (diameter approx. 120 mm) in the antenna cable at the insulator of the Antenna Coupler.
2. Put the end of the antenna cable through the hole of the insulator and fasten the bolt.
3. Prepare a piece of antenna wire (approx. 300 mm) and wind it around the insulator one turn.
4. Fasten the above piece of wire and antenna wire together with the wire clips near the ends of the piece of wire.
5. Coat the bolt with the silicone sealant.

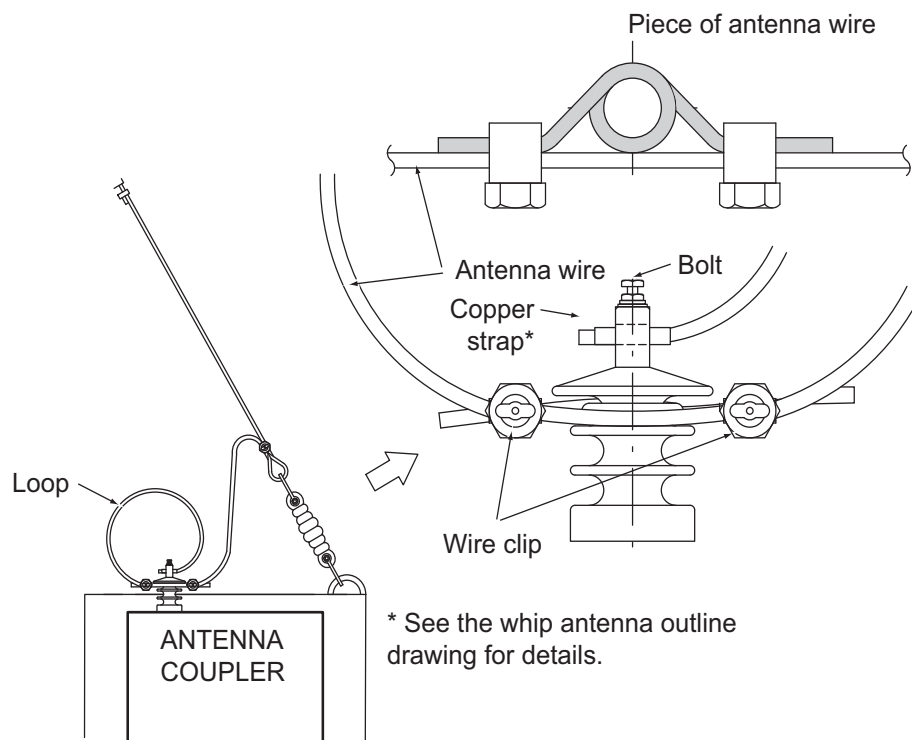

## 2.2 Transceiver Unit

### 2.2.1 General connections

The general procedure for connecting cables to the Transceiver Unit is as follows:

1. Treat the cable end. See section 2.2.4.
2. Use a knife to cut intersecting cuts in the applicable rubber bushing at the bottom of the unit.
3. Open the unit. Put the cable through the rubber bushing.  
**Note:** For the FS-1575T, insert cables in descending order of their corresponding terminal numbers; TB7→TB6→TB5...→TB1
4. **For the FS2575T/FS-5075T**, put the cable (except power cable) through a locking wire saddle at the right side of the unit.
5. Connect the cable (except power cable) to the appropriate WAGO connector on the T-IF Board. See the interconnection diagram. Use the terminal opener (attached inside the unit) to open the terminals on the connector.

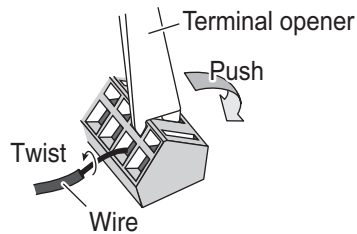

- | Procedure |  |
|-----------|--|
| 1.        | Twist core.                                    |
| 2.        | Insert terminal opener and push.               |
| 3.        | Insert wire into hole.                         |
| 4.        | Release terminal opener.                       |
| 5.        | Pull wire to confirm it is correctly inserted. |

6. Fasten a crimp-on lug to the shield of the cable. Connect the shield to the ground bar.
7. Fasten the cable to a cable fixing post with two cable ties.

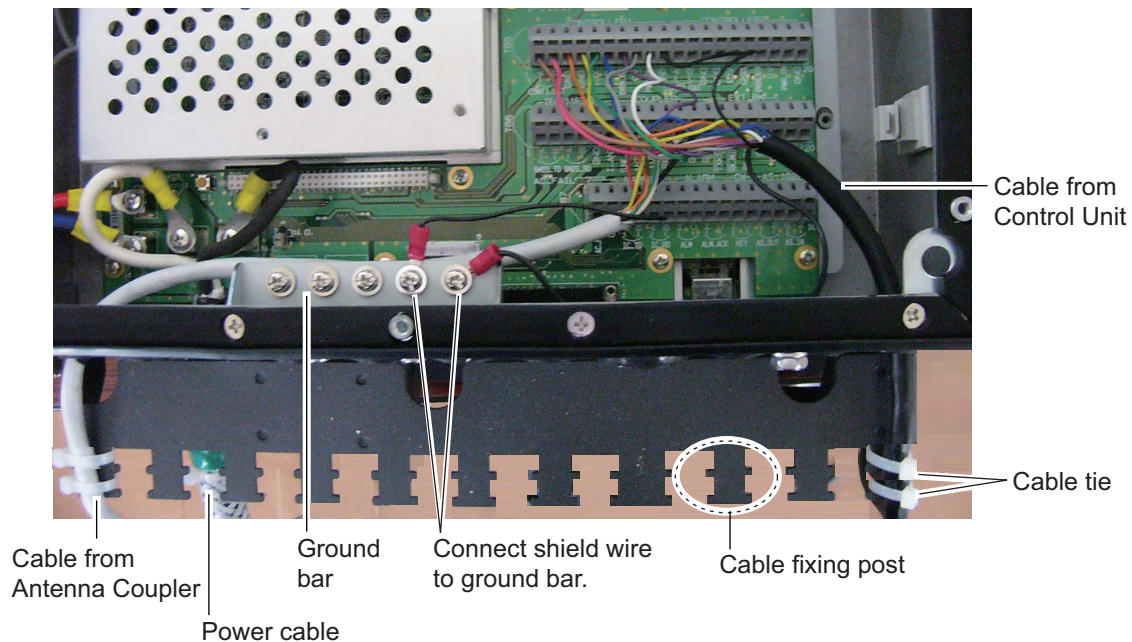

*Transceiver Unit FS-1575T, inside view*

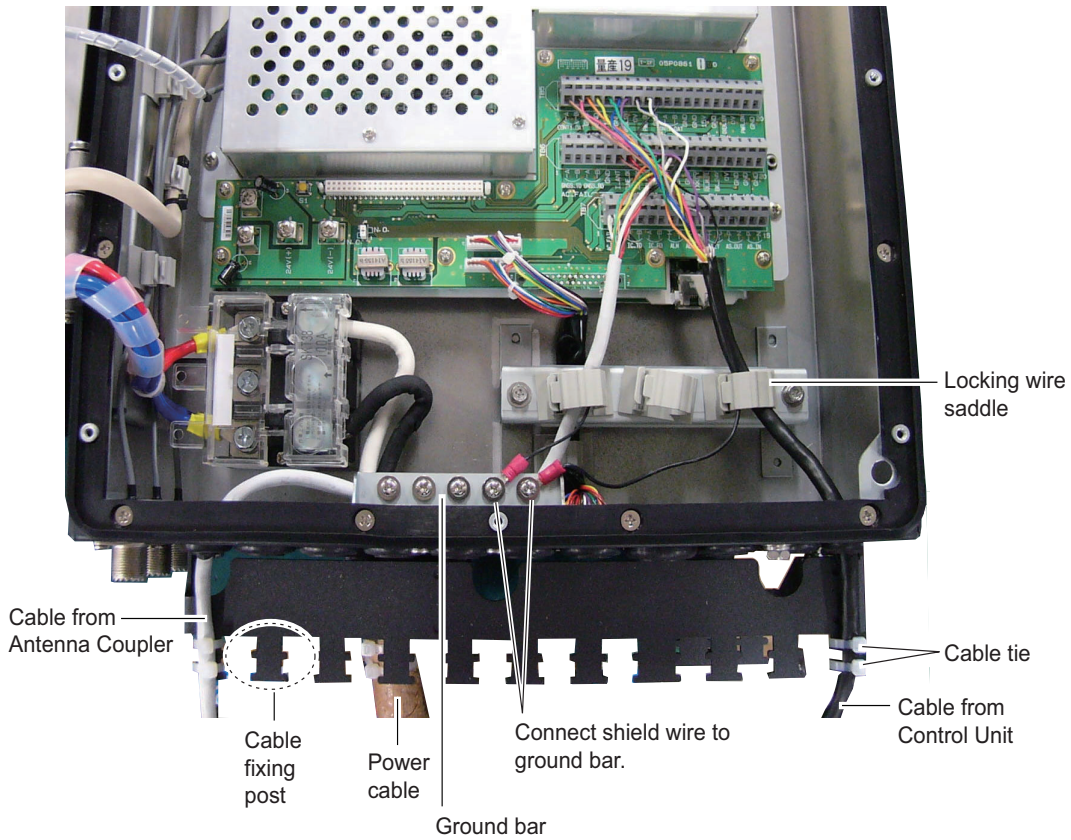

*Transceiver Unit FS-5075T, inside view*

**Note:** The inside of the FS-2575T is almost identical to that of the FS-5075T. See the illustration above for connections.

### 2.2.2 Power cable

Fabricate the cable DPYC-6 (Max 10 m, FS-1575), DPYC-10 (Max 10 m, FS-2575) or DPYC-16 (Max 10 m, FS-5075) as shown below. Attach the crimp-on lugs supplied on the 24 VDC terminal to the cable. Connect the cable to the 24 VDC terminal. If an equivalent cable is used it must not allow the voltage to drop more than 5%.

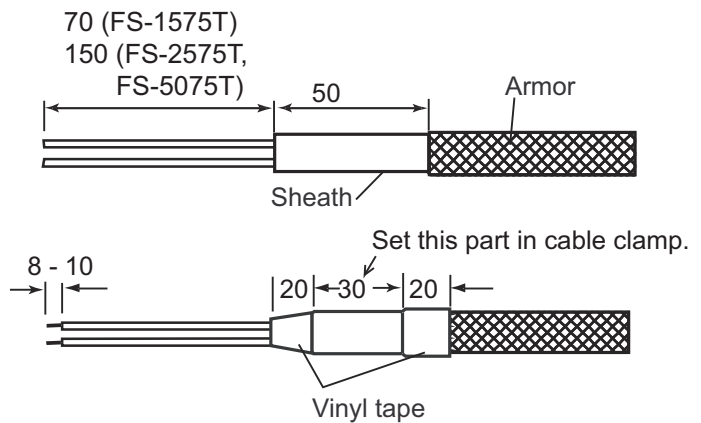

## 2. WIRING

### 2.2.3 Coaxial cable

Coaxial cables connect the antennas to the Transceiver Unit. Attach the M-type connector of the coaxial cable. Leave some slack in the coaxial cable so that the cover of the Transceiver Unit can be opened easily.

The antennas are connected to the Transceiver Unit with a 50 ohm coaxial cable, type RG-10/U-Y, RG-8A/U or 3D-2V. Lay the coaxial cable and attach an M-type plug to the cable as shown on the next page.

1. Remove the sheath by 35 mm.
2. Bare 23 mm of the conductor. Trim braided shield by 10 mm and solder.
3. Slide the coupling ring onto the cable.
4. Screw the plug assembly on the cable.
5. Solder the plug assembly to the braided shield through solder holes. Solder the contact sleeve to the conductor.
6. Screw the coupling ring into the plug assembly.
7. Screw the plug into the WR1\_ANT, WR2\_ANT, R\_ANT or T/R\_ANT receptacle on the Transceiver Unit as applicable.

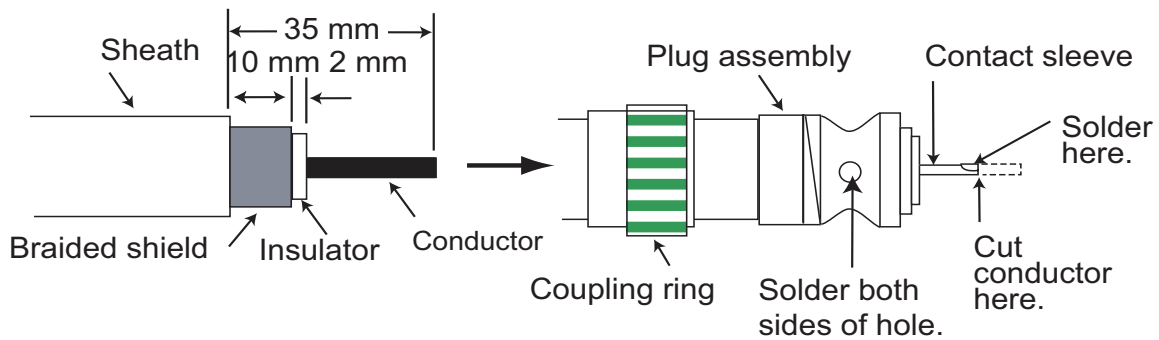

### 2.2.4 5-pair cable

Fabricate the cable as shown below. Do not unravel the twisted wire pairs.



(A) Remove sheath by approx. 15 cm (150 mm) and cut hole in shield.

(B) Pull out paper tape and inner shield from hole and cut them. Shorten shield considering its location in the transceiver.

(C) Attach crimp-on lug\* to shield. Expose cores of wires approx. 6 mm. Tape wires and shield with vinyl tape.

\* Dimensions of crimp-on lug:

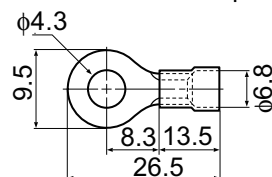

## 2.3 Control Unit

Connect the Transceiver Unit to the Control Unit with the cable with the D-sub 15-pin connector on one end. Connect a single Control Unit to the CONTROLLER 1 port. (This port has priority when two Control Units are connected.) Connect a No.2 Control Unit to the CONTROLLER 2 port.

Connect the handset HS-2003 to the HANDSET port at the front of the Control Unit. For other handset, connect to the HANDSET REAR port.

## 2.4 External Equipment

Connect cables for external equipment to the T-IF Board in the Transceiver Unit.

### GNSS

This radiotelephone can receive the following sentences in IEC 61162-1 format. Use the cable TTYCS-1/TTYCSLA-1 (or the equivalent) to connect the equipment to IEC 61162-1 of TB6 in the Transceiver Unit.

Data	Sentence, priority order
Position info, Position fix	GNS>GGA>RMC>GLL
Time info	ZDA>RMC

### Alarm Unit IC-350

Connect the Alarm Unit IC-350 to TB7 in the Transceiver Unit with the cable TTYCS-4/TTYCSLA-4 (or the equivalent).

#### Fabrication of TTYCS series

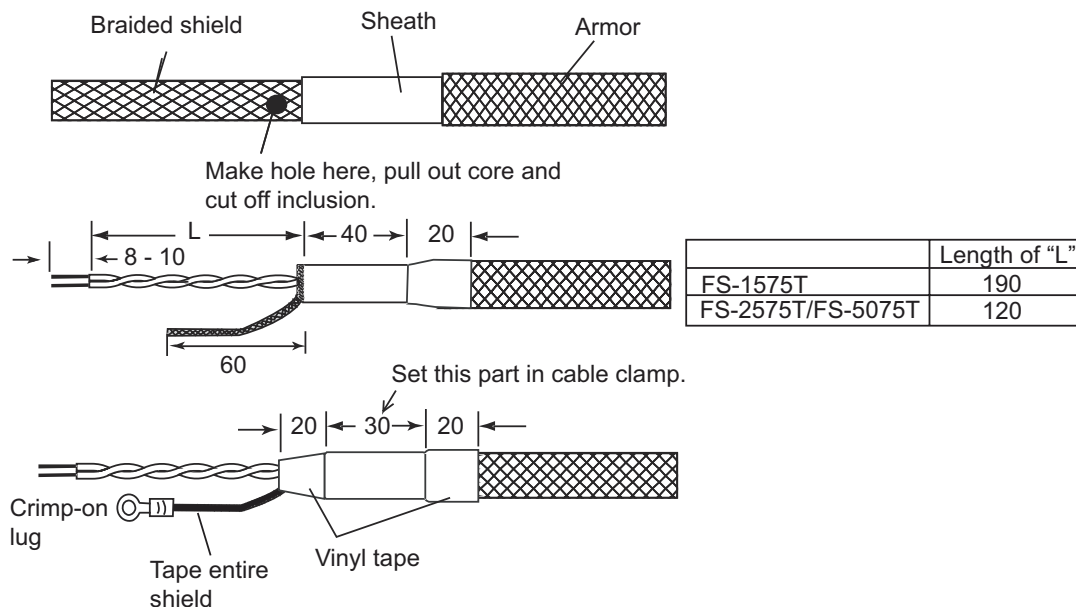

2. WIRING

*Fabrication of TTYCSLA series*

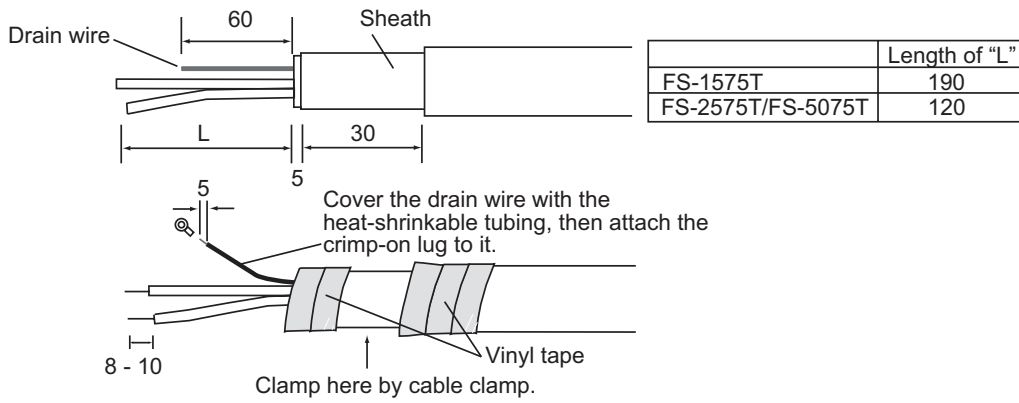

**EXT BK (SSB radiotelephone, etc.)**

Terminal no. on TB6 of T-IF Board	Signal name	Function	Object
14	$\overline{\text{TXKEY}}$	Go to GND when at TX	BK control for other radiotelephone
15	$\overline{\text{RX\_MUTE}}$	Receiver circuit muted when this line goes GND.	BK control from other radiotelephone
16	BK_24V	Output voltage: 24 VDC	Power of relay BK for other radiotelephone
17	0V	GND	0V
18	GND		

**Note:** When the GND line from other radiotelephone is connected to the chassis, float the ground.

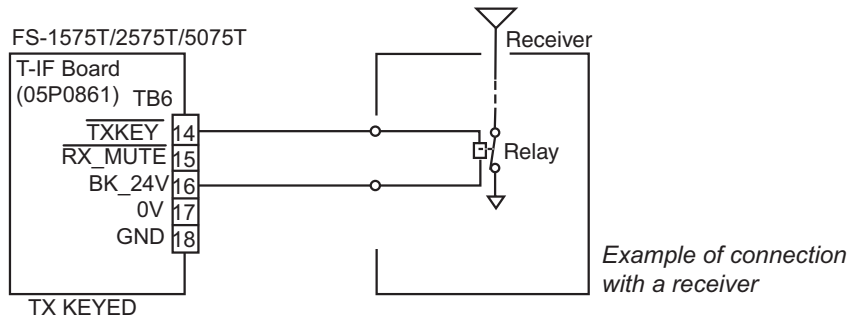

**For connection to a transceiver unit,** see the BK interface interconnection diagram at the back of this manual. Connect the SSB radiotelephone to EXT BK in the Transceiver Unit with the cable MPYC-4 (or equivalent).

**Note:** The BK interface is not required when connecting the transceiver unit FS-1575T/2575T/5075T to each other.

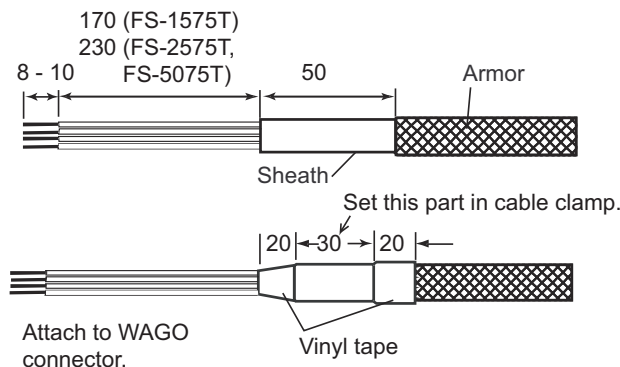



**MIF unit**

Use connector 17JE-13250-02 (supplied as installation materials) to connect the MIF unit to the REMOTE port on Transceiver Unit.

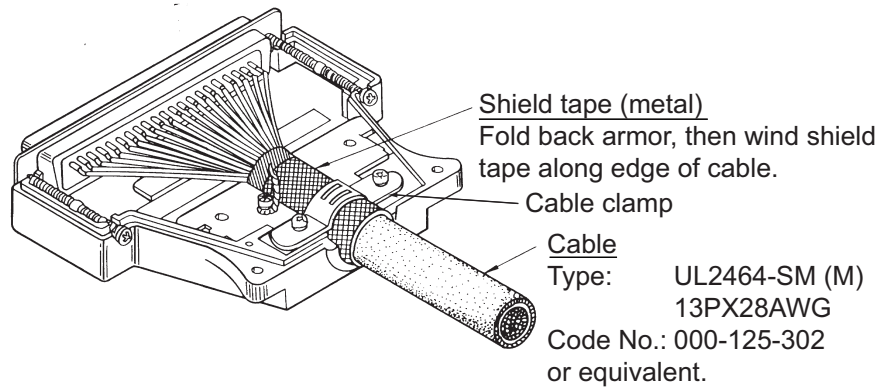

**Printer Interface IF-8500**

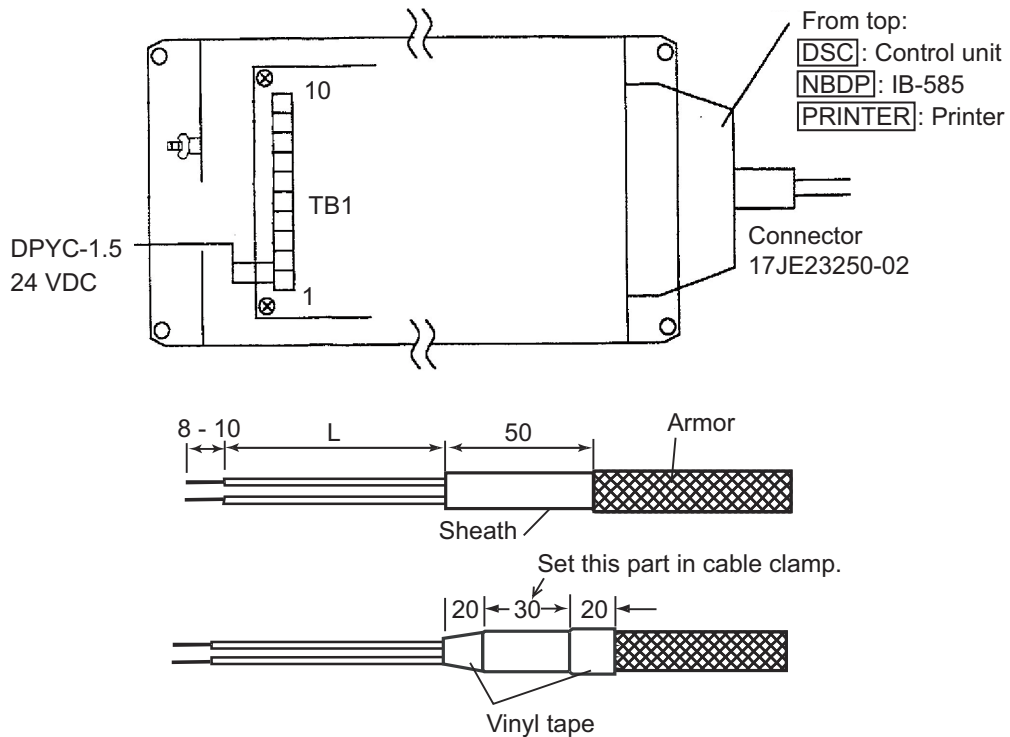

**Keyboard for Terminal Unit IB-585**

Connect the USB connector of the keyboard (5139U, 5139U BLACK or SKB-E3U) to the USB port at the front of the IB-585.

## 2.5 AC-DC Power Supply Unit PR-300/PR-850A (option)

To connect to both an AC and DC ship's mains, the optional AC-DC power supply unit PR-300 (FS-1575) or PR-850A (FS-2575/FS-5075) is required. Attach the crimp on lug FV5.5-4 (local supply) to the following cables or equivalent (local supply) for connection with the power supply unit.

- AC power: DPYC-6
- DC power: DPYC-6 (FS-1575), DPYC-10 (FS-2575), DPYC-16 (FS-5075)

### How to process power cables

Fabricate the cable as shown below. Connect cables to their input terminals with crimp-on lugs.

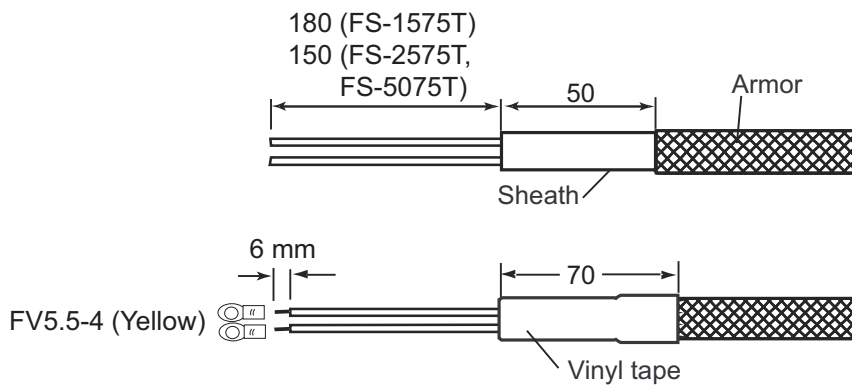

### How to select input voltage

#### **PR-300 for FS-1575:**

The input voltage is adjustable for 100/110/200/220 VAC, and is factory-set for 220 VAC. To select other input voltages, open the top cover and change the wiring according to the figure on the next page and change the power fuse accordingly to AC input voltage as follows.

Input voltage	Power fuse
100/110 VAC	10 A
200/220 VAC	5 A

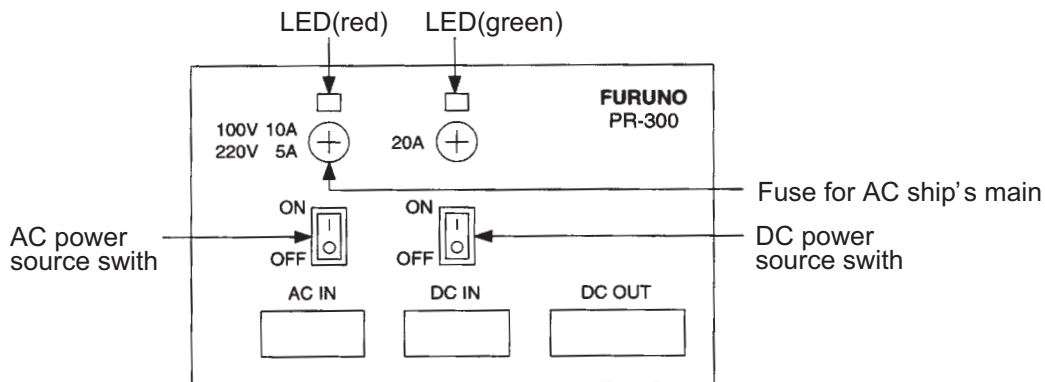

AC-DC power supply unit PR-300, rear view

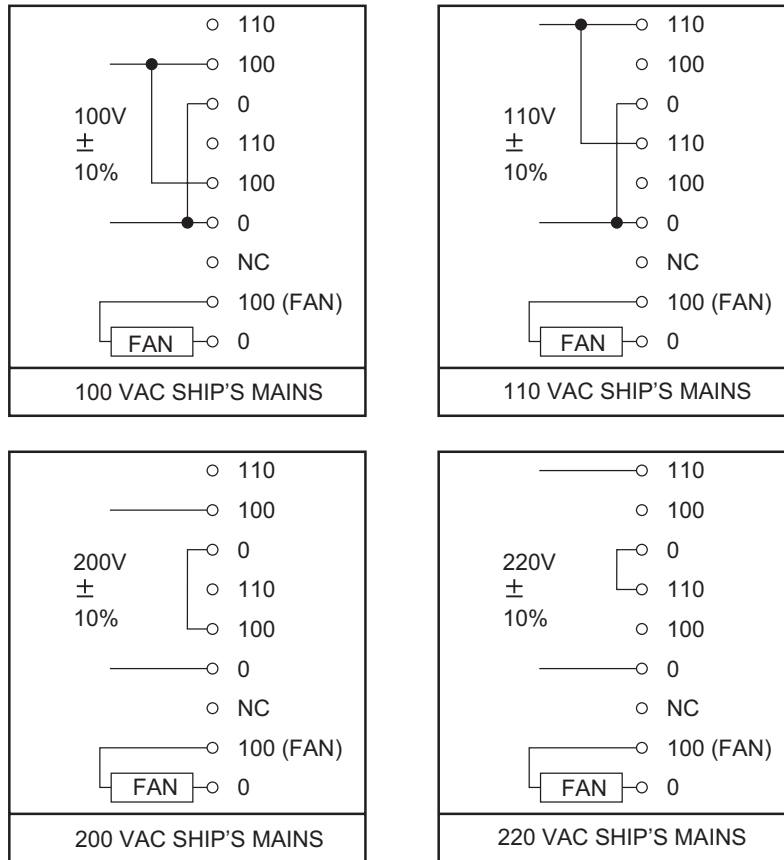

Tap connections in the PR-300

**PR-850A for FS-2575/5075:**

The input voltage is adjustable for 100/110/120/200/220/240 VAC, and is factory-set for 220 VAC. To select other input voltages, open the top cover and change the wiring according to the figure on the next page. After changing the input voltage, correct the sticker on the front panel accordingly.

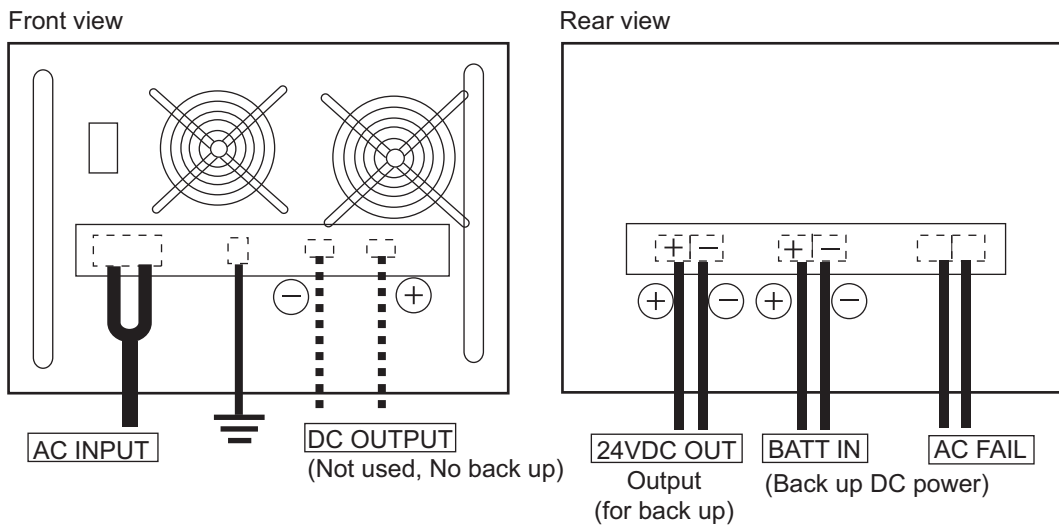

2. WIRING

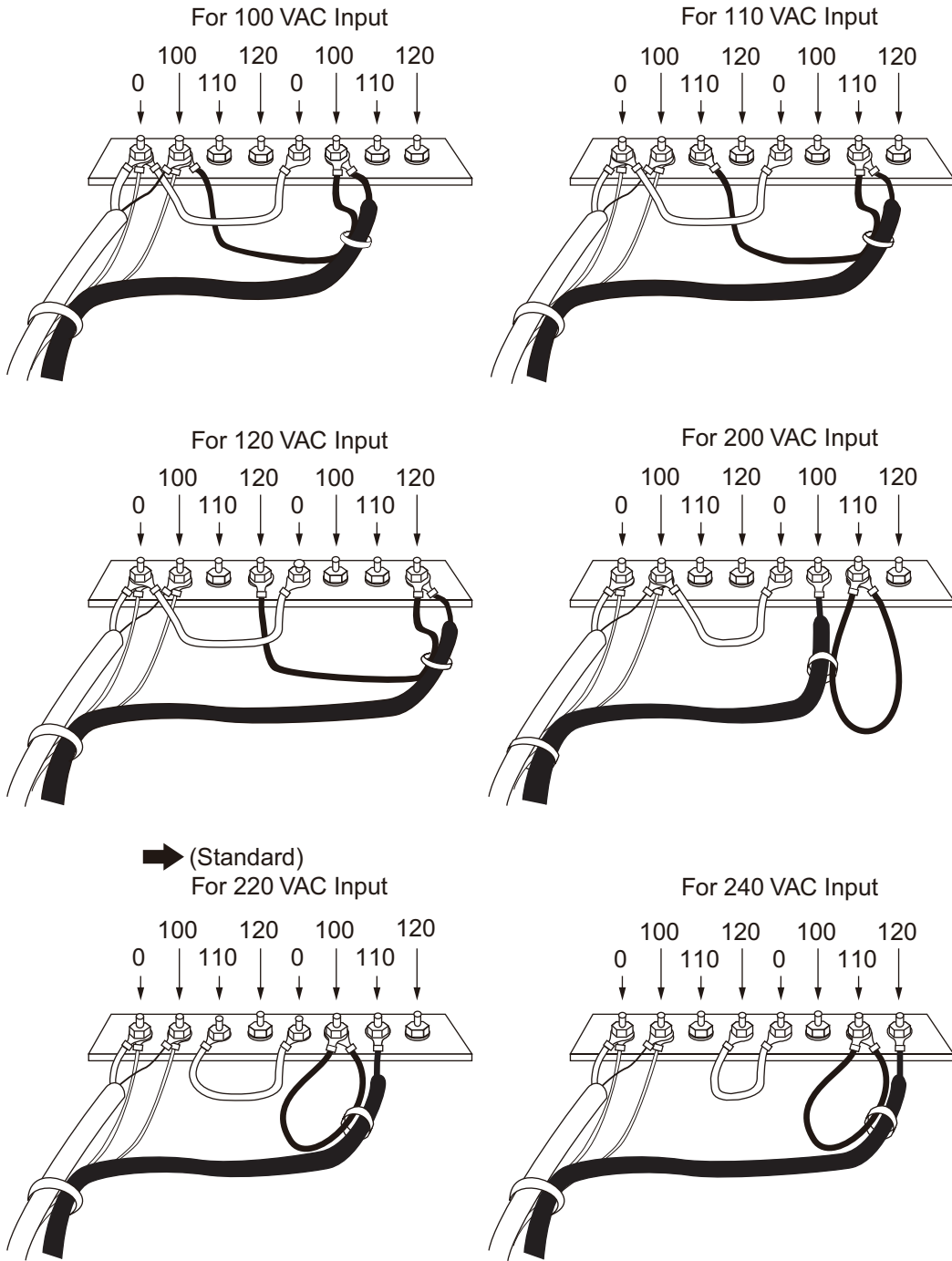

**AC FAIL line (PR-850A)**

When the power supply is switched to the back-up, AC and FAIL at PR-850A are shorted as shown in the figure at right.

**Note:** When the AC-FAIL line is connected, output power reduction function is available. For a GMDSS vessel installed FS-5075, connect the AC-FAIL line.

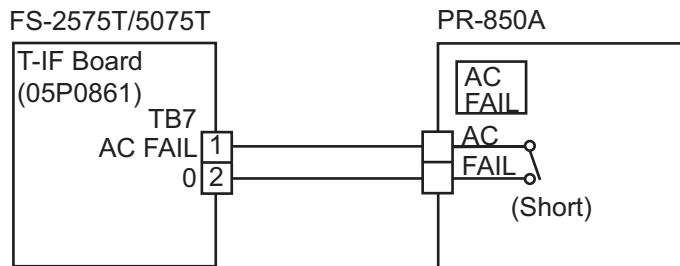

## 2.6 Automatic Antenna Switch AS-102 (option)

The Automatic Antenna Switch AS-102 allows you to connect the antenna to ground remotely with an external switch when there is a possibility of lightning, or the antenna must be grounded to meet with local regulations when returning to a harbor. Install the unit between the antenna and the Antenna Coupler. When you do not use this unit, the antenna is connected to ground in the Antenna Coupler by turning off the radio-telephone.

Connect the SSB antenna to the ANT terminal, and use the antenna cable to connect the TRX terminal and the Antenna Coupler (ANT terminal) as shown below. For the signal cable, connect the DPYCY-1.5 (or DPYC-1.5) cable between the Transceiver Unit and the Automatic Antenna Switch as shown below. For outside installation, follow the procedure in section 2.1.2.

**Note:** An external switch (user supply) can be installed to turn off the antenna manually. See the interconnection diagram.

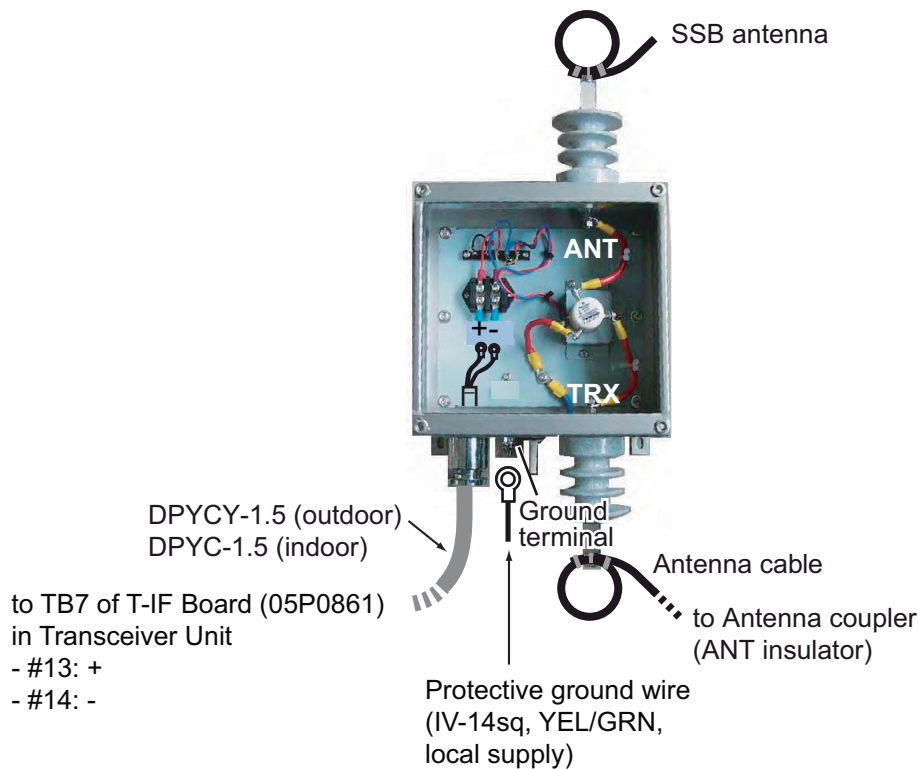

### How to process the cable (example: DPYCY-1.5)

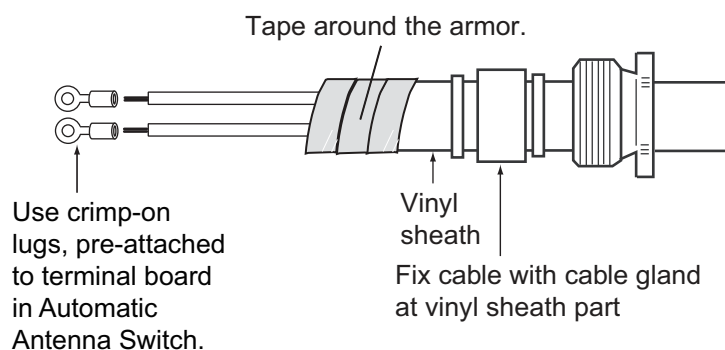

## 2. WIRING

This page is intentionally left blank.

# 3. INITIAL SETTINGS

This chapter shows you how to enter the initial settings. A password is required to enter the initial settings. Refer to FURUNO Information for the password.

## 3.1 How to Initialize the Control Unit and Transceiver Unit

Turn on the power switch on the Control Unit. The equipment starts to update the software, in the sequence shown below. When the procedure is completed, the radiotelephone screen appears.

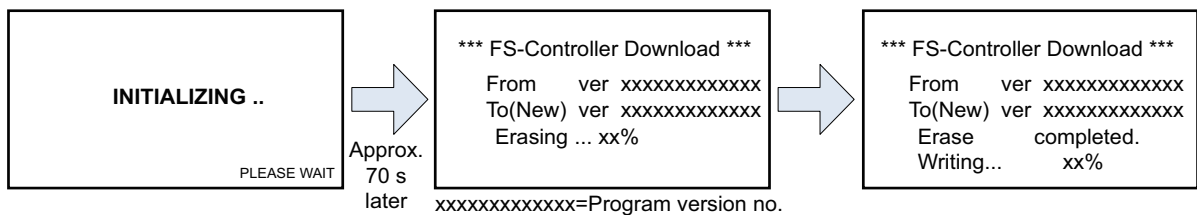

## 3.2 How to Enter MMSI

1. Turn on the Control Unit. Open the Transceiver Unit and press and hold the Reset switch S1 (approx. 5 seconds) on the T-IF Board (05P0861) until the menu shown below appears on the Control Unit.

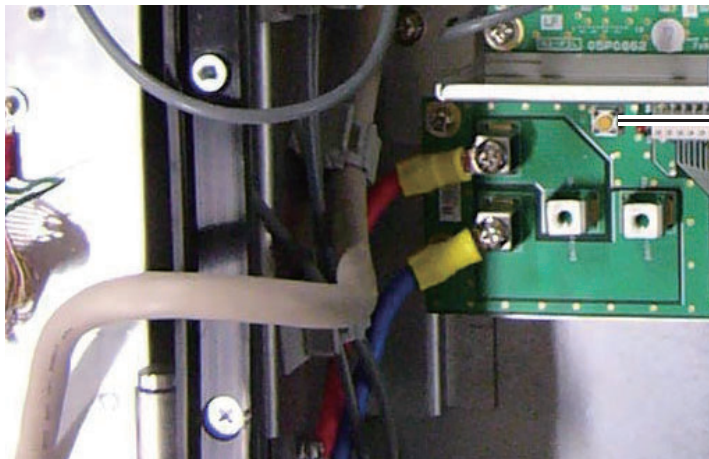

Push Reset switch S1 until the menu shown below appears on the Control Unit.

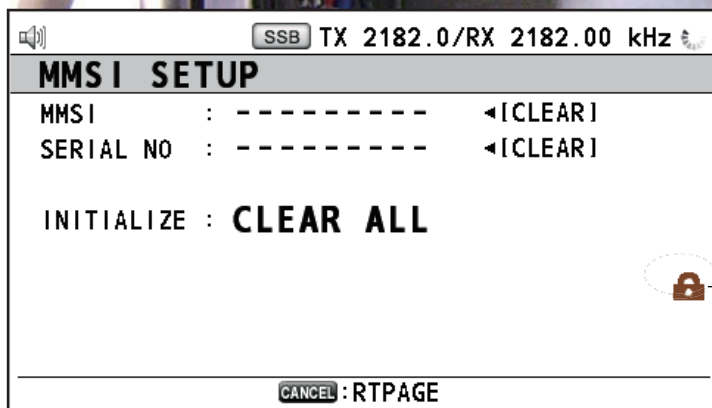

Lock icon (brown)

### 3. INITIAL SETTINGS

2. Enter the password. The lock icon turns green, the shackle of the lock opens and the cursor selects the MMSI area. Push the **Rotary** knob to show the MMSI input box.
3. Use the numeric keys to enter the MMSI.
4. Push the **Rotary** knob to register the MMSI.

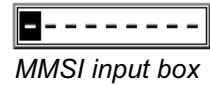

**Note:** You can re-enter the MMSI if it is wrong. Select ◀[CLEAR] then push the **Rotary** knob. You are asked "MMSI Clear OK?". Select [Yes] then push the **Rotary** knob. Select the MMSI number input area then push the **Rotary** knob. Enter the MMSI.

## 3.3 Performance Check

Power the system and check the receiver and transmitter as follows:

### Receiver

1. Set the unit as follows:  
Speaker: ON, Squelch: OFF, AGC: Fast, Gain: Maximum
2. Confirm that a signal can be received on each band. If noise is present or a signal is weak, check the antenna lead-in section, coaxial cable and ground.

### Transmitter

1. On each band, confirm that the antenna is tuned when the **0/TUNE** key is pressed. If "tuning error" appears, check the antenna (connection, ground, etc.).
2. Communicate with the handset. Confirm that IA and IC change with voice level.

## 3.4 System Setup

This section shows you how to access the [SERVICE] menu, and enter the system setting.

### 3.4.1 SERVICE menu

A password is required to access the [SERVICE] menu. For details of the [SERVICE] menu, see the service manual of the FS-1575/2575/5075.

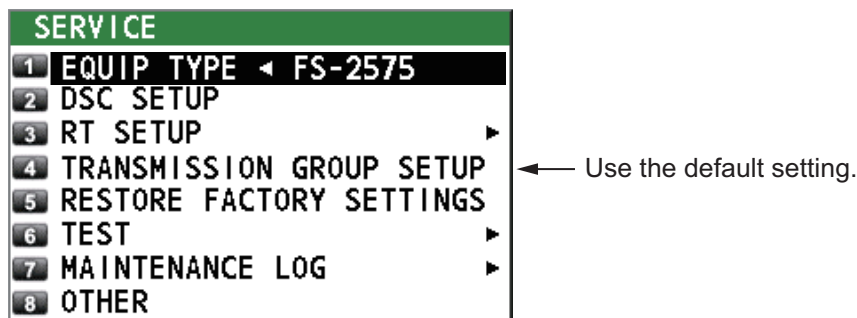

### 3.4.2 EQUIP TYPE menu

The system automatically detects the model name and displays the results, [FS-1575], [FS-2575] or [FS-5075].



### 3.4.3 DSC SETUP menu

The [DSC SETUP] menu sets up the system's DSC features.

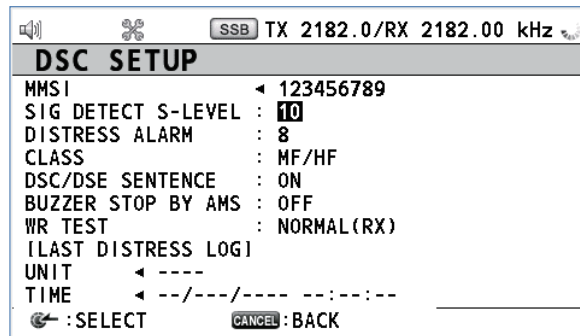

**MMSI:** Ship's MMSI (display only).

**CLASS:** Set the function of the watch receiver: [MF/HF] (sea area A3), [MF] (sea area A1, A2), or [NON-GMDSS] (DSC function disabled).

### 3.4.4 RT SETUP menu

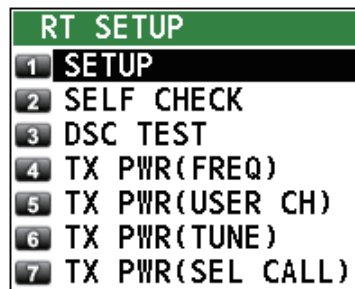

#### SETUP

The [RT SETUP] menu sets functions according to needs and regulations and adjusts TX power.

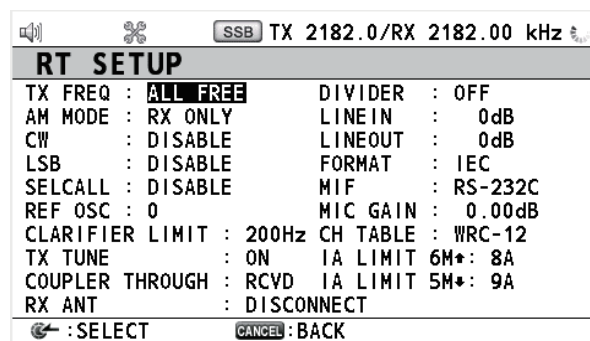

**CW:** Enable or disable CW. [ENABLE]: On, [DISABLE]: Off

**SELCALL:** Enable or disable the selective call radio buoy feature. When enabled, function key **F3** is automatically assigned to the selective call buoy feature. [ENABLE]: On, [DISABLE]: Off

**REF OSC:** Tune the reference oscillator.

**RX ANT:** Select whether an RX antenna is connected or not. [CONNECT]: RX antenna connected. [DISCONNECT]: RX antenna not connected

**DIVIDER:** Divider connection. [ON]: Divider connected. [OFF]: Divider not connected.

### 3. INITIAL SETTINGS

**FORMAT:** Select sentence format. [IEC]: Sentences for IEC 61162 Ed.4/Ed.5 received. [IEC+NMEA]: Sentences for IEC 61162 Ed.3 and NMEA received. [IEC+NMEA-EM]: Sentences for IEC 61162 Ed.3 and NMEA received. However, GNS/GLL/RMC sentences with a mode indicator of E or M are not received.

**CH TABLE:** Select channel table from [WRC-7] or [WRC-12]. Select [WRC-12] usually. If frequency clearance is not revised from country to country, select [WRC-7].

#### TX PWR (FREQ)

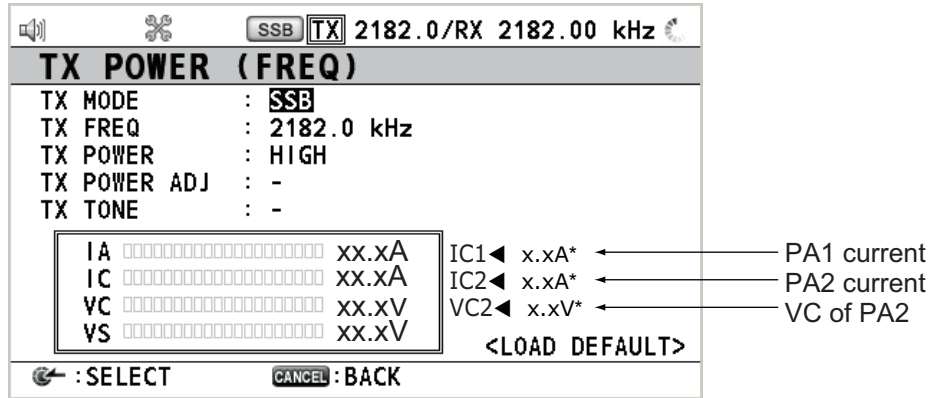

\* Shown for FS-5075 only

TX power can fluctuate on certain frequencies depending on antenna location. If this occurs, adjust the TX power on the problem frequency.

**TX MODE:** Select the mode for which to set TX power.

**TX FREQ:** Select the frequency.

**TX POWER:** Set the output level.

**TX POWER ADJ:** Set the TX power.

**TX TONE:** Output tone.

**LOAD DEFAULT:** Restore default TX power (frequency) settings.

For details of the settings on the [TX POWER (FREQ)] menu, see the service manual of FS-1575/2575/5075.

#### TX PWR (USER CH)

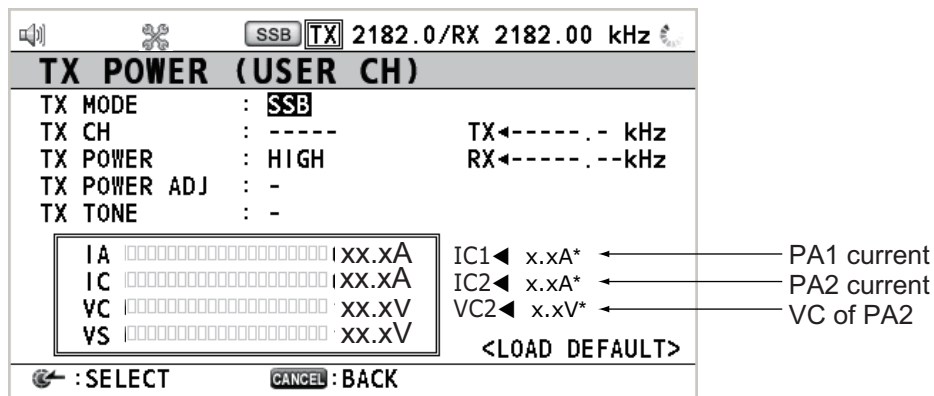

\* Shown for FS-5075 only

TX power on user channels can fluctuate according to antenna location. If this occurs, adjust the TX power on user channels.

**TX MODE:** Select the mode for which to set TX power.

**TX FREQ:** Select the frequency.

**TX POWER:** Set the output level.

**TX POWER ADJ:** Set the TX power.

**TX TONE:** Output tone.

**LOAD DEFAULT:** Restore default TX power (user channel) settings.

For details of the settings on the [TX POWER (USER CH)] menu, see the service manual of FS-1575/2575/5075.

### 3.4.5 OTHER menu

SSB TX 2182.0/RX 2182.00 kHz	
<b>OTHER</b>	
[for SERVICE]	[for DEVELOP]
PA : ON	DEBUG MODE : OFF
P-BROWSER : OFF	
ACF_POWER : LOW2	
ALARM UNIT : DISCONNECT	
AMS MODE : LEGACY	
RMS : OFF	
SOFTWARE ERASE	
← : SELECT      CANCEL : BACK	

**P-BROWSER** : Select [ON] to enable the parameter browser, controlled from a PC.

**ALARM UNIT** : Select [CONNECT] if Alarm Unit IC-350 is connected.

**AMS MODE** : Select the AMS (alert management system) mode.

[LEGACY] (default): When [LEGACY] is selected, the FS-xx75 will not input/output the following sentences:

- Input: ACK, ACN, HBT
- Output: ALC, ALF, ALR, ARC, HBT

[AlertIF1]: When AlertIF1 is selected, the FS-xx75 will input/output the following sentences:

- Input: ACK
- Output: ALR

[AlertIF2]: When AlertIF2 is selected, the FS-xx75 will input/output the following sentences.

- Input: ACN, HBT
- Output: ALF, ALC, ARC, HBT

### 3.4.6 Example antenna configurations

#### Separate Antennas Configurations

##### *Separate antennas configuration 1: Separate R\_ANT and WR1 antennas*

- 1) Set [RX ANT] on the [RT SETUP] menu to [CONNECT].
- 2) Set [ANT SELECT] on the [RT SETUP] menu to [RX ANT] or [TRX ANT].
- 3) Turn off [DIVIDER] in the [RT SETUP] menu of the [SERVICE] menu.

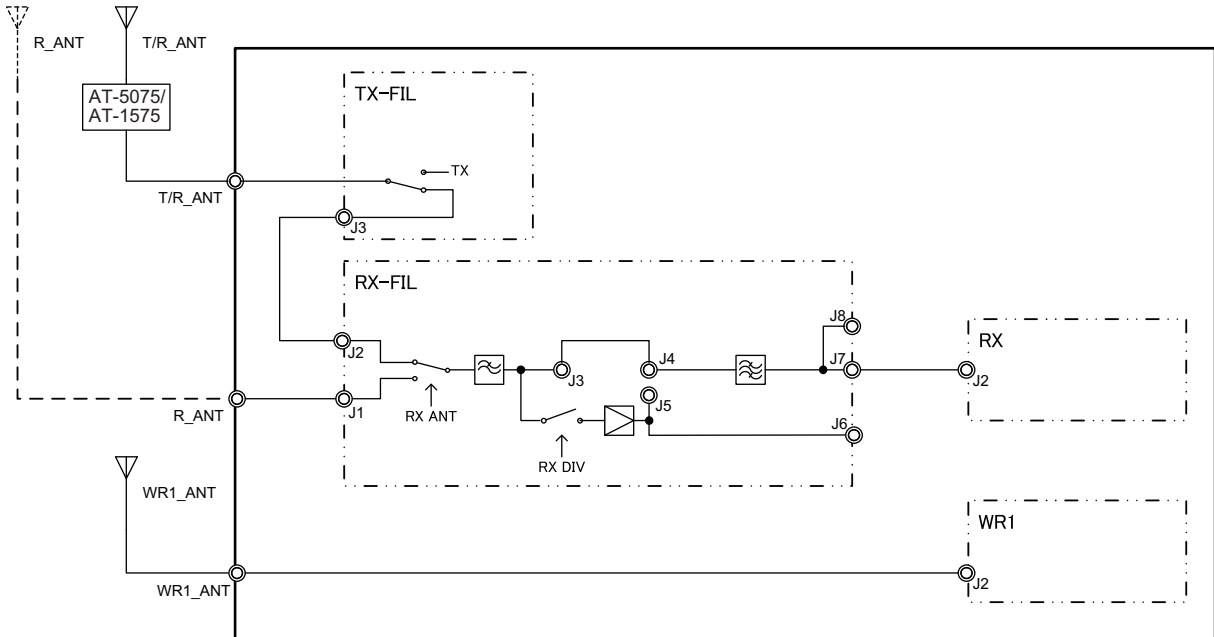

##### *Separate antennas configuration 2: Separate R\_ANT and WR1 antennas, optional WR2 board installed*

- 1) Set [RX ANT] on the [RT SETUP] menu to [CONNECT].
- 2) Set [ANT SELECT] on the [RT SETUP] menu to [RX ANT] or [TRX ANT].
- 3) Turn off [DIVIDER] in the [RT SETUP] menu of the [SERVICE] menu.

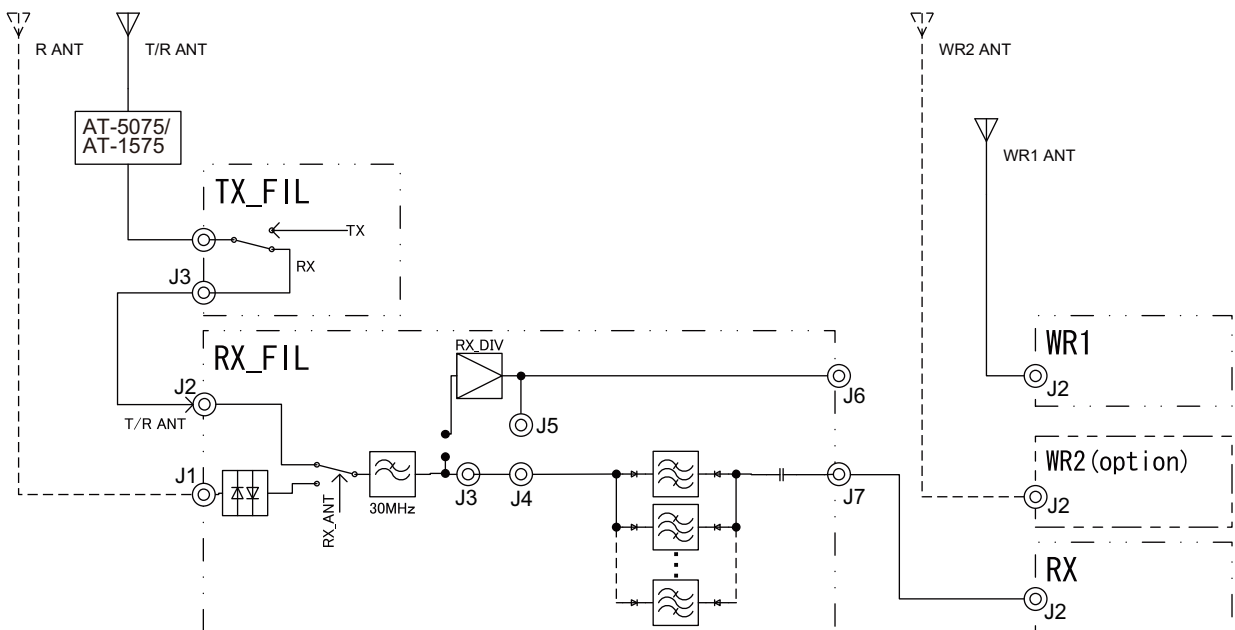

**Shared antenna configurations**

***Shared antenna configuration 1: R\_ANT and WR1 antennas commonly shared***

- 1) Set [RX ANT] on the [RT SETUP] menu in the [SERVICE] menu to [CONNECT].
- 2) Turn on [DIVIDER] in the [RT SETUP] menu of the [SERVICE] menu.
- 3) Use the mini-pin assemblies (supplied) to make these connections:
  - Connect J4 to J5 on the RX FIL Board.
  - Connect J6 on RX FIL Board to J2 on WR1 Board.

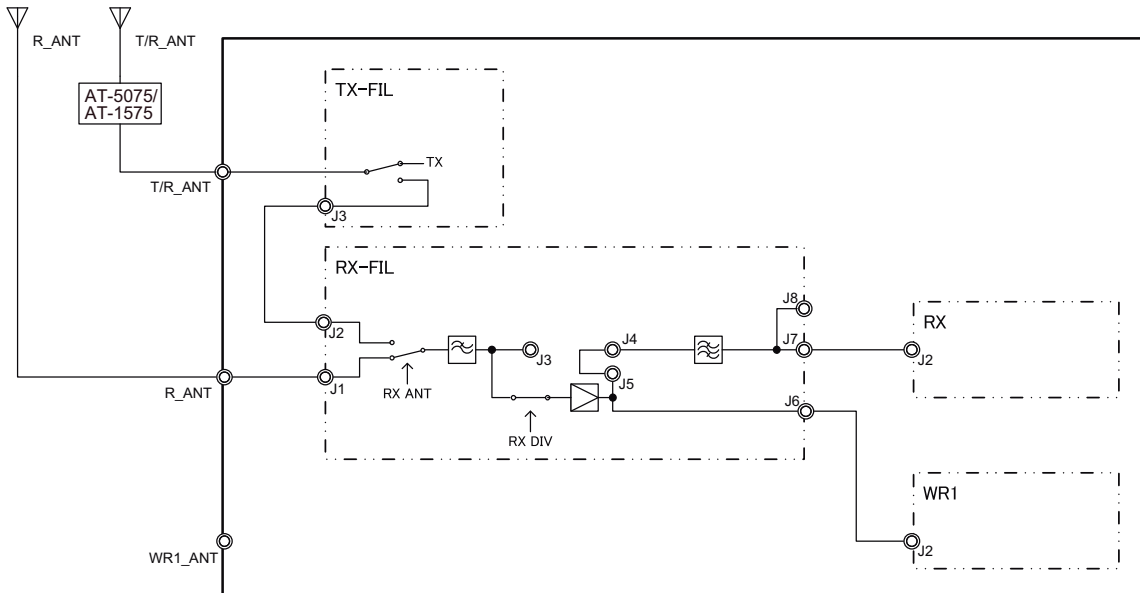

***Shared antenna configuration 2: R\_ANT and WR2 antennas commonly shared, optional WR2 board installed***

Optional WR2 Board installed to watch on DSC general frequencies.

- 1) Set [RX ANT] on the [RT SETUP] menu to [CONNECT].
- 2) Turn on [DIVIDER] in the [RT SETUP] menu.
- 3) Use the mini-pin assemblies (supplied) to make these connections:
  - Connect J4 to J5 on the RX FIL Board.
  - Connect J6 on RX FIL Board to J2 on WR1 Board.

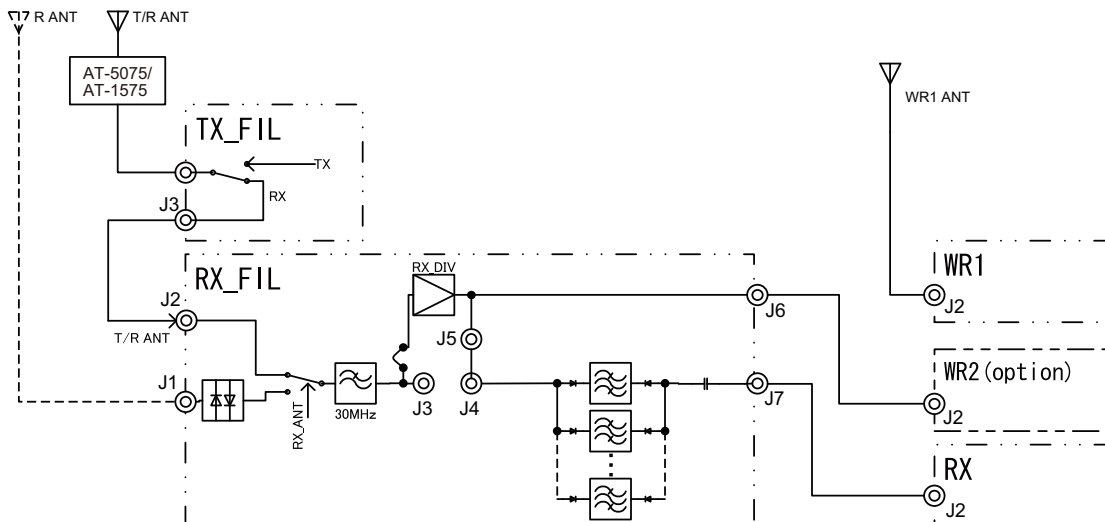

### 3. INITIAL SETTINGS

#### **Full duplex configurations (FS-5075 only)**

##### ***Full duplex configuration 1: Separate R\_ANT and WR1 antennas, optional DUP-FIL board installed***

Watch on DSC general frequencies available with installation of optional WR2 Board.

- 1) Set [RX ANT] on the [RT SETUP] menu to [CONNECT].
- 2) Set [ANT SELECT] on the [RT SETUP] menu to [RX ANT].
- 3) Turn off [DIVIDER] in the [RT SETUP] menu of the [SERVICE] menu.

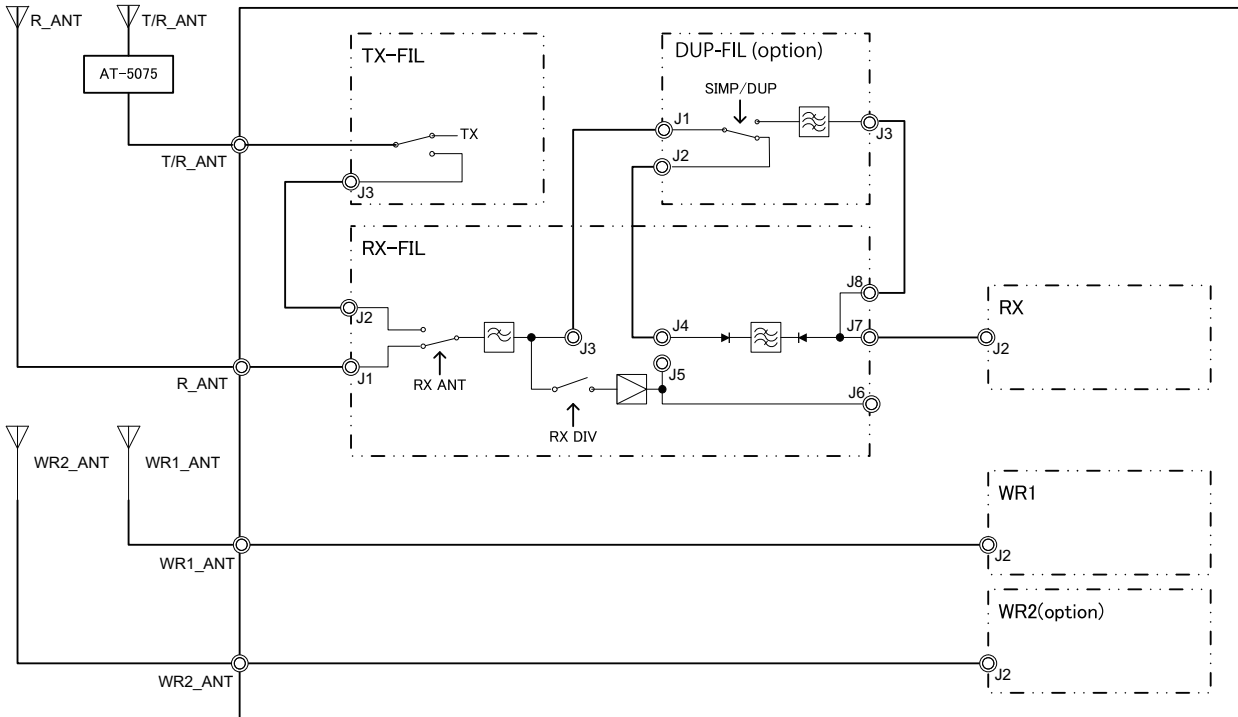

**Full duplex configuration 2: R\_ANT and WR2 antennas commonly shared**

- 1) Set [RX ANT] on the [RT SETUP] menu to [CONNECT].
- 2) Set [ANT SELECT] on the [RT SETUP] menu to [RX ANT].
- 3) Turn on [DIVIDER] in the [RT SETUP] menu of the [SERVICE] menu.

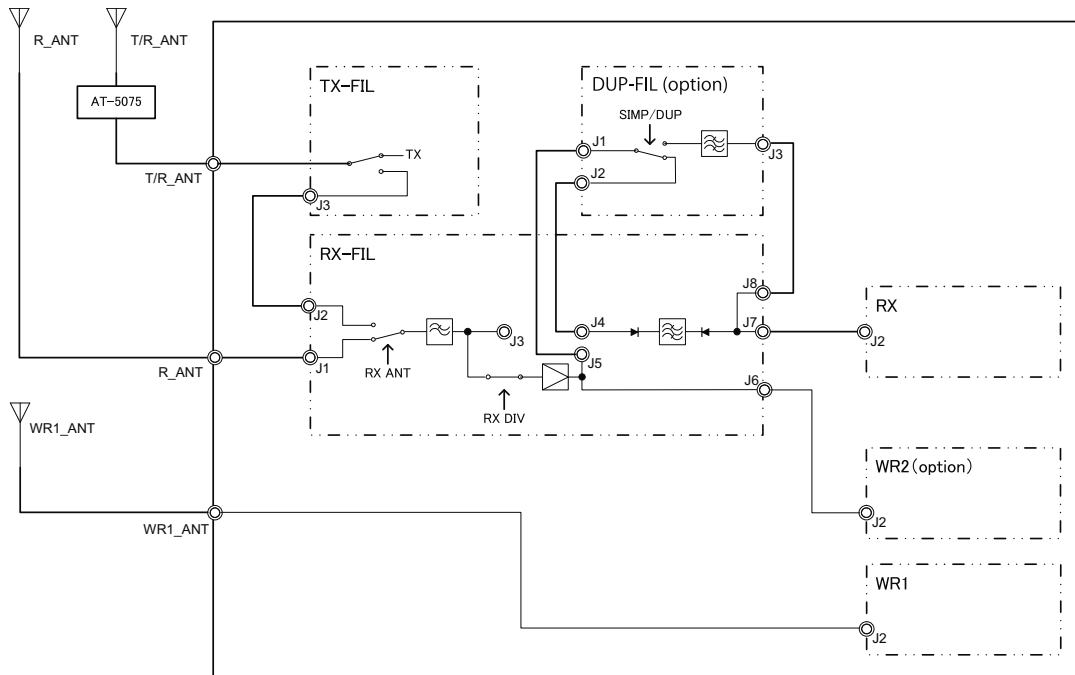

### 3.5 Alarm Contact Signal

Set the format of the alarm contact signal for normal close or normal open, with the jumper block J8 on the T-IF Board (05P0861).

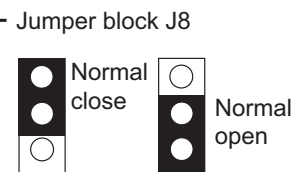
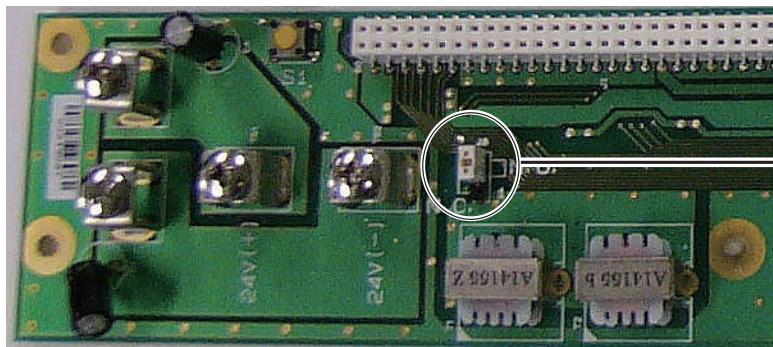

## 3.6 I/O Data

<b>Data</b>	<b>Input/Output</b>	<b>Sentence, priority order</b>
Alert command	Input	ACN
Position info, Position fix	Input	GNS>GGA>RMC>GLL
Time info	Input	ZDA>RMC
Alert acknowledgment	Input	ACK
Heart beat supervision	Input/Output	HBT
DSC information, Expanded DSC	Output	DSC, DSE
Alert state	Output	ALR
Alert sentence	Output	ALF
Alert command refused	Output	ARC
Cyclic alert list	Output	ALC



# APPENDIX 1 JIS CABLE GUIDE

Cables listed in the manual are usually shown as Japanese Industrial Standard (JIS). Use the following guide to locate an equivalent cable locally.

JIS cable names may have up to 6 alphabetical characters, followed by a dash and a numerical value (example: DPYC-2.5).

For core types D and T, the numerical designation indicates the *cross-sectional Area (mm<sup>2</sup>)* of the core wire(s) in the cable.

For core types M and TT, the numerical designation indicates the *number of core wires* in the cable.

## 1. Core Type

D: Double core power line

T: Triple core power line

M: Multi core

TT: Twisted pair communications  
(1Q=quad cable)

## 2. Insulation Type

P: Ethylene Propylene

Rubber

## 3. Sheath Type

Y: PVC (Vinyl)

## 4. Armor Type

C: Steel

## 5. Sheath Type

Y: Anticorrosive vinyl sheath

## 6. Shielding Type

S: All cores in one sheath

-S: Individually sheathed cores

SLA: All cores in one shield, plastic tape w/aluminum tape

-SLA: Individually shielded cores, plastic tape w/aluminum tape



DPYCY



TPYCY

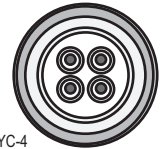

MPYC-4

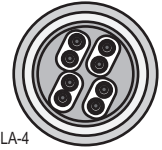

TTYCSLA-4

EX: <sup>1</sup> <sup>2</sup> <sup>3</sup> <sup>4</sup> <sup>5</sup> <sup>6</sup> TTYCYSLA - 4  
Designation type    Core Area (mm<sup>2</sup>)

EX: <sup>1</sup> <sup>2</sup> <sup>3</sup> <sup>4</sup> MPYC - 4  
Designation type    # of cores

The following reference table lists gives the measurements of JIS cables commonly used with Furuno products:

Type	Core		Cable Diameter	Type	Core		Cable Diameter
	Area	Diameter			Area	Diameter	
DPYC-1.5	1.5mm <sup>2</sup>	1.56mm	11.7mm	TTYCS-1	0.75mm <sup>2</sup>	1.11mm	10.1mm
DPYC-2.5	2.5mm <sup>2</sup>	2.01mm	12.8mm	TTYCS-1T	0.75mm <sup>2</sup>	1.11mm	10.6mm
DPYC-4	4.0mm <sup>2</sup>	2.55mm	13.9mm	TTYCS-1Q	0.75mm <sup>2</sup>	1.11mm	11.3mm
DPYC-6	6.0mm <sup>2</sup>	3.12mm	15.2mm	TTYCS-4	0.75mm <sup>2</sup>	1.11mm	16.3mm
DPYC-10	10.0mm <sup>2</sup>	4.05mm	17.1mm	TTYCSLA-1	0.75mm <sup>2</sup>	1.11mm	9.4mm
DPYCY-1.5	1.5mm <sup>2</sup>	1.56mm	13.7mm	TTYCSLA-1T	0.75mm <sup>2</sup>	1.11mm	10.1mm
DPYCY-2.5	2.5mm <sup>2</sup>	2.01mm	14.8mm	TTYCSLA-1Q	0.75mm <sup>2</sup>	1.11mm	10.8mm
DPYCY-4	4.0mm <sup>2</sup>	2.55mm	15.9mm	TTYCSLA-4	0.75mm <sup>2</sup>	1.11mm	15.7mm
MPYC-2	1.0mm <sup>2</sup>	1.29mm	10.0mm	TTYCY-1	0.75mm <sup>2</sup>	1.11mm	11.0mm
MPYC-4	1.0mm <sup>2</sup>	1.29mm	11.2mm	TTYCY-1T	0.75mm <sup>2</sup>	1.11mm	11.7mm
MPYC-7	1.0mm <sup>2</sup>	1.29mm	13.2mm	TTYCY-1Q	0.75mm <sup>2</sup>	1.11mm	12.6mm
MPYC-12	1.0mm <sup>2</sup>	1.29mm	16.8mm	TTYCY-4	0.75mm <sup>2</sup>	1.11mm	17.7mm
TPYC-1.5	1.5mm <sup>2</sup>	1.56mm	12.5mm	TTYCY-4S	0.75mm <sup>2</sup>	1.11mm	21.1mm
TPYC-2.5	2.5mm <sup>2</sup>	2.01mm	13.5mm	TTYCY-4SLA	0.75mm <sup>2</sup>	1.11mm	19.5mm
TPYC-4	4.0mm <sup>2</sup>	2.55mm	14.7mm	TTYCYS-1	0.75mm <sup>2</sup>	1.11mm	12.1mm
TPYCY-1.5	1.5mm <sup>2</sup>	1.56mm	14.5mm	TTYCYS-4	0.75mm <sup>2</sup>	1.11mm	18.5mm
TPYCY-2.5	2.5mm <sup>2</sup>	2.01mm	15.5mm	TTYCYSLA-1	0.75mm <sup>2</sup>	1.11mm	11.2mm
TPYCY-4	4.0mm <sup>2</sup>	2.55mm	16.9mm	TTYCYSLA-4	0.75mm <sup>2</sup>	1.11mm	17.9mm





# PACKING LIST

FS-1575T-J/E/J-HK

05ER-X-9851 -0

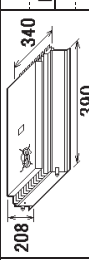
1/1

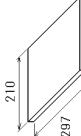
A-1

NAME	OUTLINE	DESCRIPTION/CODE No.	QTY
<b>ユニット</b>			
送受信部 TRANSEIVER UNIT		FS-1575T-J/E/J-HK 000-020-900-00 **	1
<b>工事材料</b>			
<b>INSTALLATION MATERIALS</b>			
工事材料 INSTALLATION MATERIALS		CP05-12001 001-135-560-00	1
<b>図書</b>			
<b>DOCUMENT</b>			
取扱説明書 OPERATOR'S MANUAL		OM*-56770-* 000-175-164-1* **	1
操作要領書 OPERATOR'S GUIDE		OS*-56770-* 000-175-166-1* **	1
装備要領書 INSTALLATION MANUAL		IM*-56770-* 000-175-168-1* **	1

コード番号末尾の[\*\*]は、選択品の代表コードを表します。  
CODE NUMBER ENDING WITH "\*\*" INDICATES THE CODE NUMBER OF REPRESENTATIVE MATERIAL.

型式/コード番号が2段の場合、下段より上段に代わる過渡期品であり、どちらが入っています。なお、品質は変わりません。  
TWO TYPES AND CODES MAY BE LISTED FOR AN ITEM. THE LOWER PRODUCT MAY BE SHIPPED IN PLACE OF THE UPPER PRODUCT. QUALITY IS THE SAME.  
(略図の寸法は、参考値です。DIMENSIONS IN DRAWING FOR REFERENCE ONLY.)

C5676-Z01-A



# PACKING LIST

FS-2575T-J/E/J-HK

05EO-X-9851 -1

1/1

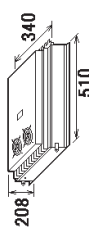
A-2

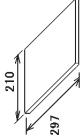
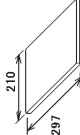
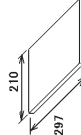
NAME	OUTLINE	DESCRIPTION/CODE No.	QTY
<b>ユニット</b>			
送受信部 TRANSEIVER UNIT		FS-2575T-J/E/J-HK 000-019-234-00 **	1
<b>工事材料</b>			
<b>INSTALLATION MATERIALS</b>			
工事材料 INSTALLATION MATERIALS		CP05-12001 001-135-560-00	1
<b>図書</b>			
<b>DOCUMENT</b>			
取扱説明書 OPERATOR'S MANUAL		OM*-56770-* 000-175-164-1* **	1
操作要領書 OPERATOR'S GUIDE		OS*-56770-* 000-175-166-1* **	1
装備要領書 INSTALLATION MANUAL		IM*-56770-* 000-175-168-1* **	1

コード番号末尾の[\*\*]は、選択品の代表コードを表します。  
CODE NUMBER ENDING WITH "\*\*" INDICATES THE CODE NUMBER OF REPRESENTATIVE MATERIAL.

型式/コード番号が2段の場合、下段より上段に代わる過渡期品であり、どちらが入っています。なお、品質は変わりません。  
TWO TYPES AND CODES MAY BE LISTED FOR AN ITEM. THE LOWER PRODUCT MAY BE SHIPPED IN PLACE OF THE UPPER PRODUCT. QUALITY IS THE SAME.  
(略図の寸法は、参考値です。DIMENSIONS IN DRAWING FOR REFERENCE ONLY.)

C5677-Z01-B

# PACKING LIST

## FS-5075T-J/E/J-HK

05EO-X-9852 -1 1/1  
A-3

NAME UNIT	OUTLINE	DESCRIPTION/CODE No.	Q'TY
<b>ユニット</b>			
送受信部 TRANSMITTER UNIT		FS-5075T-J/E/J-HK 000-019-237-00 ***	1
<b>工事材料</b>	<b>INSTALLATION MATERIALS</b>		
工事材料 INSTALLATION MATERIALS		CP05-12001 001-135-560-00	1
<b>図書</b>			
取扱説明書 OPERATOR'S MANUAL		01**-56770-* 000-175-164-1* **	1
操作要領書 OPERATOR'S GUIDE		05**-56770-* 000-175-166-1* **	1
装册要領書 INSTALLATION MANUAL		11**-56770-* 000-175-168-1* **	1

コード番号末尾の[\*\*]は、選用品の代表コードを表します。  
CODE NUMBER ENDING WITH "\*\*" INDICATES THE CODE NUMBER OF REPRESENTATIVE MATERIAL.

型式/コード番号が2段の場合、下段より上段に代わる過渡期品であり、どちらが入っています。なお、品質は変わりません。  
TWO TYPES AND CODES MAY BE LISTED FOR AN ITEM. THE LOWER PRODUCT MAY BE SHIPPED IN PLACE OF THE UPPER PRODUCT. QUALITY IS THE SAME.  
(略図の寸法は、参考値です。DIMENSIONS IN DRAWING FOR REFERENCE ONLY.)

CS678-Z01-B

# PACKING LIST

## FS-2575C-J-A/E-A/J-A-HK

05EO-X-9854 -0 1/1  
A-4

NAME UNIT	OUTLINE	DESCRIPTION/CODE No.	Q'TY
<b>ユニット</b>			
操作表示部 CONTROL UNIT		FS-2575C-J/E/J-HK 000-019-240-00 ***	1
<b>付属品</b>	<b>ACCESSORIES</b>		
ハンドセット HANDSET		HS-2003-15 000-015-996-00	1
ハンドセットカギ組品 BRACKET FOR HANDSET		FP05-05510 005-951-790-00	1
付属品 ACCESSORIES		FP05-05511 005-951-920-00	1
<b>工事材料</b>	<b>INSTALLATION MATERIALS</b>		
ケーブル組品 CABLE ASSEMBLY		DSUB15-5P-L5M 001-146-850-10	1
工事材料 INSTALLATION MATERIALS		CP05-12101 001-135-570-00	1
<b>図書</b>			
運難警報7B-(HF) DISTRESS ALERT CHART (HF)		*52-00102-* 000-809-271-1* **	1
運難警報7B-(VHF/MF) DISTRESS ALERT CHART (VHF/MF)		*52-00101-* 000-809-269-1* **	1

コード番号末尾の[\*\*]は、選用品の代表コードを表します。  
CODE NUMBER ENDING WITH "\*\*" INDICATES THE CODE NUMBER OF REPRESENTATIVE MATERIAL.

型式/コード番号が2段の場合、下段より上段に代わる過渡期品であり、どちらが入っています。なお、品質は変わりません。  
TWO TYPES AND CODES MAY BE LISTED FOR AN ITEM. THE LOWER PRODUCT MAY BE SHIPPED IN PLACE OF THE UPPER PRODUCT. QUALITY IS THE SAME.  
(略図の寸法は、参考値です。DIMENSIONS IN DRAWING FOR REFERENCE ONLY.)

CS677-Z06-A

# PACKING LIST

## AT-1575-AES/-HK

A-6

NAME	OUTLINE	DESCRIPTION/CODE No.	Q'TY
ユニット			
アンテナコプラ		AT-1575-AES/-HK	1
ANTENNA COUPLER		000-020-911-00 **	
工事材料	INSTALLATION MATERIALS		
工事材料		CP05-12901	1
INSTALLATION MATERIALS		001-175-190-00	

コード番号末尾の[\*\*]は、選択品の代表コードを表します。  
CODE NUMBER ENDING WITH "\*\*" INDICATES THE CODE NUMBER OF REPRESENTATIVE MATERIAL.

型式/コード番号が2段の場合、下段より上段に代わる過渡期品であり、どちらが入っています。なお、品質は変わりません。  
TWO TYPES AND CODES MAY BE LISTED FOR AN ITEM. THE LOWER PRODUCT MAY BE SHIPPED IN PLACE OF THE UPPER PRODUCT. QUALITY IS THE SAME.  
(略図の寸法は、参考値です。DIMENSIONS IN DRAWING FOR REFERENCE ONLY.)

05676-202-A

# PACKING LIST

## FS-2575C-J-N/E-N/J-N-HK

A-5

NAME	OUTLINE	DESCRIPTION/CODE No.	Q'TY
ユニット			
操作表示部		FS-2575C-J/E/J-HK	1
CONTROL UNIT		000-019-240-00 **	
付属品	ACCESSORIES	FP05-06600	
ハンドセット		HS-2003-15	1
HANDSET		000-015-996-00	
ハンドセット用組品		FP05-05510	1
BRACKET FOR HANDSET		005-951-790-00	
付属品		FP05-05511	1
ACCESSORIES		005-951-920-00	
工事材料	INSTALLATION MATERIALS	CP05-12100	
工事材料		CP05-12101	1
INSTALLATION MATERIALS		001-135-570-00	
図書	DOCUMENT		
運搬警報カード (HF)		*52-00102-*	1
DISTRESS ALERT CHART (HF)		000-809-271-1* **	
運搬警報カード (VHF/MF)		*52-00101-*	1
DISTRESS ALERT CHART (VHF/MF)		000-809-269-1* **	



コード番号末尾の[\*\*]は、選択品の代表コードを表します。  
CODE NUMBER ENDING WITH "\*\*" INDICATES THE CODE NUMBER OF REPRESENTATIVE MATERIAL.

型式/コード番号が2段の場合、下段より上段に代わる過渡期品であり、どちらが入っています。なお、品質は変わりません。  
TWO TYPES AND CODES MAY BE LISTED FOR AN ITEM. THE LOWER PRODUCT MAY BE SHIPPED IN PLACE OF THE UPPER PRODUCT. QUALITY IS THE SAME.  
(略図の寸法は、参考値です。DIMENSIONS IN DRAWING FOR REFERENCE ONLY.)

05677-202-B

# PACKING LIST

AT-5075/HK  
05EO-X-9855 -0 1/1  
A-7

N A M E	U N I T	O U T L I N E	D E S C R I P T I O N / C O D E N o.	Q ' T Y
ユニット アンテナカプラ ANTENNA COUPLER			AT-5075/HK 000-019-243-00 ***	1
工事材料 INSTALLATION MATERIALS			GP05-12201 001-135-590-00	1

コード番号末尾の[\*\*]は、選択品の代表コードを表します。  
CODE NUMBER ENDING WITH "\*\*" INDICATES THE CODE NUMBER OF REPRESENTATIVE MATERIAL.



型式/コード番号が2段の場合、下段より上段に代わる過渡期品であり、どちらかが入っています。なお、品質は変わりません。  
TWO TYPES AND CODES MAY BE LISTED FOR AN ITEM. THE LOWER PRODUCT MAY BE SHIPPED IN PLACE OF THE UPPER PRODUCT. QUALITY IS THE SAME.

(略図の寸法は、参考値です。DIMENSIONS IN DRAWING FOR REFERENCE ONLY.)

C5677-703-A

# PACKING LIST

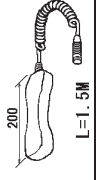
SP05-06000  
05EO-X-9856 -0 1/1  
A-8

N A M E	S P A R E P A R T S	O U T L I N E	D E S C R I P T I O N / C O D E N o.	Q ' T Y
予備品 ハンドセット HANDSET			HS-2003-15 000-015-996-00	1
予備品 SPARE PARTS			SP05-06001 001-135-530-00	1

型式/コード番号が2段の場合、下段より上段に代わる過渡期品であり、どちらかが入っています。なお、品質は変わりません。  
TWO TYPES AND CODES MAY BE LISTED FOR AN ITEM. THE LOWER PRODUCT MAY BE SHIPPED IN PLACE OF THE UPPER PRODUCT. QUALITY IS THE SAME.



(略図の寸法は、参考値です。DIMENSIONS IN DRAWING FOR REFERENCE ONLY.)

C5677-704-A

## PACKING LIST

SP05-06300

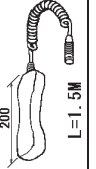
A-10

NAME	UNIT	OUTLINE	DESCRIPTION/CODE No.	QTY
ユニット ハンドセット			HS-2003-15	1
予備品 予備品	SPARE PARTS		000-015-996-00	
SPARE PARTS			SP05-06301	1
			001-174-840-00	

型式/コード番号が2段の場合、下段より上段に代わる過渡期品であり、どちらが入っています。なお、品質は変わりません。

TWO TYPES AND CODES MAY BE LISTED FOR AN ITEM. THE LOWER PRODUCT MAY BE SHIPPED IN PLACE OF THE UPPER PRODUCT. QUALITY IS THE SAME.



(略図の寸法は、参考値です。DIMENSIONS IN DRAWING FOR REFERENCE ONLY.)

C5676-Z04-A

## PACKING LIST

SP05-06100

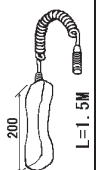
A-9

NAME	UNIT	OUTLINE	DESCRIPTION/CODE No.	QTY
予備品 ハンドセット			HS-2003-15	1
予備品 予備品	SPARE PARTS		000-015-996-00	
SPARE PARTS			SP05-06101	1
			001-135-540-00	

型式/コード番号が2段の場合、下段より上段に代わる過渡期品であり、どちらが入っています。なお、品質は変わりません。

TWO TYPES AND CODES MAY BE LISTED FOR AN ITEM. THE LOWER PRODUCT MAY BE SHIPPED IN PLACE OF THE UPPER PRODUCT. QUALITY IS THE SAME.

(略図の寸法は、参考値です。DIMENSIONS IN DRAWING FOR REFERENCE ONLY.)

C5677-Z05-A

CODE NO.	001-135-580-00	05EO-X-9403-3
TYPE	CP05-12001	1/1

工事材料表		INSTALLATION MATERIALS		FS-1575T/2575T/5075T	
番号 NO.	名称 NAME	略図 OUTLINE	型名/規格 DESCRIPTIONS	数量 QTY	用途/備考 REMARKS
1	セルフタッピングネジ 1/2 SELF-TAPPING SCREW		φ630 SUS304 CODE NO. 000-162-614-10	6	
2	コネクタ (M) COAXIAL CONNECTOR *M TYPE*		GSC-100/MP-7 CODE NO. 000-166-977-11	2	
3	ミニピン組品 (1) MINI PIN ASSY (1)		L-380 CODE NO. 000-165-859-10	1	
4	ポリカーボネートワッシャー POLYCARBONATE WASHER		M6 P.C CODE NO. 000-168-259-10	6	
5	コネクタ (M2) CONNECTOR (D-SUB)		MM2S-2513-S014 CODE NO. 001-115-850-10	1	

(略図の寸法は、参考値です。 DIMENSIONS IN DRAWING FOR REFERENCE ONLY.)

FURUNO ELECTRIC CO., LTD.

CODE NO.	001-135-590-00	05EO-X-9405-0
TYPE	CP05-12201	1/1

工事材料表		INSTALLATION MATERIALS		AT-5075/HK	
番号 NO.	名称 NAME	略図 OUTLINE	型名/規格 DESCRIPTIONS	数量 QTY	用途/備考 REMARKS
1	グラウンドパッド GROUND GASKET 1		05-106-3619-0 CODE NO. 100-366-120-10	1	
2	六角ナット 1/2 HEXAGONAL NUT		M6 SUS304 CODE NO. 000-168-856-10	4	
3	ミカキ平座金 FLAT WASHER		M6 SUS304 CODE NO. 000-168-854-10	8	
4	六角スリットネジ HEX. BOLT (SLOTTED WASHER HEAD)		M6X30 SUS304 CODE NO. 000-162-837-10	4	



型式/コード番号が2段の場合、下段より上段に代わる過渡部品であり、どちらかが入っています。 なお、品質は変わりません。

TWO TYPES AND CODES MAY BE LISTED FOR AN ITEM. THE LOWER PRODUCT MAY BE SHIPPED IN PLACE OF THE UPPER PRODUCT. QUALITY IS THE SAME. DIMENSIONS IN DRAWING FOR REFERENCE ONLY.)

FURUNO ELECTRIC CO., LTD.

CODE NO.	001-175-190-00	05ER-X-9401-0	1/1
TYPE	CP05-12901		

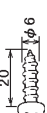
**工事材料表**











番号 NO.	名称 NAME	略図 OUTLINE	型名/規格 DESCRIPTIONS	数量 QTY	用途/備考 REMARKS
1	自己付着タップ SELF-TAPPING SCREW		6X20 SUS304 CODE NO. 000-163-871-10	4	
2	フラットワッシャー FLAT WASHER		M6 SUS304 CODE NO. 000-165-864-10	4	

型式/コード番号が2段の場合、下段より上段に代わる標準部品であり、どちらが入っています。なお、品質は変わりません。  
 TWO TYPES AND CODES MAY BE LISTED FOR AN ITEM. THE LOWER PRODUCT MAY BE SHIPPED IN PLACE OF THE UPPER PRODUCT. QUALITY IS THE SAME.  
 (略図の寸法は、参考値です。 DIMENSIONS IN DRAWING FOR REFERENCE ONLY.)

CODE NO.	05EO-X-9406-1	1/1
TYPE		

**工事材料表**

AT-1575/1575-HK/5075/5075-HK (CP05-123\*\*/108\*\*)

番号 NO.	名称 NAME	略図 OUTLINE	型名/規格 DESCRIPTIONS	数量 QTY	用途/備考 REMARKS
1	7-7 5P 5P TWISTED PAIR CABLE		05S0793-0 *10M* CODE NO. 000-125-884-10	1	(*) 選択 TO BE SELECTED
2	7-7 5P 5P TWISTED PAIR CABLE		05S0793-0 *20M* CODE NO. 000-125-886-10	1	(*) 選択 TO BE SELECTED
3	7-7 5P 5P TWISTED PAIR CABLE		05S0793-0 *30M* CODE NO. 000-125-887-10	1	(*) 選択 TO BE SELECTED
4	7-7 5P 5P TWISTED PAIR CABLE		05S0793-0 *40M* CODE NO. 000-125-888-10	1	(*) 選択 TO BE SELECTED
5	7-7 5P 5P TWISTED PAIR CABLE		05S0793-0 *50M* CODE NO. 000-125-889-10	1	(*) 選択 TO BE SELECTED
6	7-7 7C CABLE (7C)		05S0952 *10M* CODE NO. 000-758-821-10	1	(*) 選択 TO BE SELECTED
7	7-7 7C CABLE (7C)		05S0952 *20M* CODE NO. 000-758-822-10	1	(*) 選択 TO BE SELECTED
8	7-7 7C CABLE (7C)		05S0952 *30M* CODE NO. 000-758-823-10	1	(*) 選択 TO BE SELECTED
9	7-7 7C CABLE (7C)		05S0952 *40M* CODE NO. 000-758-824-10	1	(*) 選択 TO BE SELECTED
10	7-7 7C CABLE (7C)		05S0952 *50M* CODE NO. 000-758-825-10	1	(*) 選択 TO BE SELECTED





(\*)、(\*\*)より選択願います。  
 CHOOSE ONE FROM \*1 AND \*2.

型式/コード番号が2段の場合、下段より上段に代わる標準部品であり、どちらが入っています。なお、品質は変わりません。  
 TWO TYPES AND CODES MAY BE LISTED FOR AN ITEM. THE LOWER PRODUCT MAY BE SHIPPED IN PLACE OF THE UPPER PRODUCT. QUALITY IS THE SAME.  
 (略図の寸法は、参考値です。 DIMENSIONS IN DRAWING FOR REFERENCE ONLY.)



# FURUNO

CODE NO.	05E0-X-9409 -1
TYPE	CP05-124**

工事材料表		FS-1575/2575/5075		05E0-X-9409 -1		1/1
INSTALLATION MATERIALS	略 図 OUTLINE	型名/規格 DESCRIPTIONS	数量 Q T Y	用途/備考 REMARKS		
番号 NO.	名 称 NAME					
1	ケーブル組品 CABLE ASSEMBLY	 L=10M	DSUB15-5P-L10M CODE NO. 001-I46-880-10	1	*選択 TO BE SELECTED	
2	ケーブル組品 CABLE ASSEMBLY	 L=20M	DSUB15-5P-L20M CODE NO. 001-I46-870-10	1	*選択 TO BE SELECTED	
3	ケーブル組品 CABLE ASSEMBLY	 L=30M	DSUB15-5P-L30M CODE NO. 001-I46-880-10	1	*選択 TO BE SELECTED	
4	ケーブル組品 CABLE ASSEMBLY	 L=40M	DSUB15-5P-L40M CODE NO. 001-I46-880-10	1	*選択 TO BE SELECTED	
5	ケーブル組品 CABLE ASSEMBLY	 L=50M	DSUB15-5P-L50M CODE NO. 001-I46-900-10	1	*選択 TO BE SELECTED	

型式/コード番号が2段の場合、下段より上段に代わる濃淡糊品であり、どちらが入っています。なお、品質は変わりません。

TWO TYPES AND CODES MAY BE LISTED FOR AN ITEM. THE LOWER PRODUCT MAY BE SHIPPED IN PLACE OF THE UPPER PRODUCT. QUALITY IS THE SAME. DIMENSIONS IN DRAWING FOR REFERENCE ONLY.)

(略図の寸法は、参考値です。)

FURUNO ELECTRIC CO., LTD.

C5677-M08-B

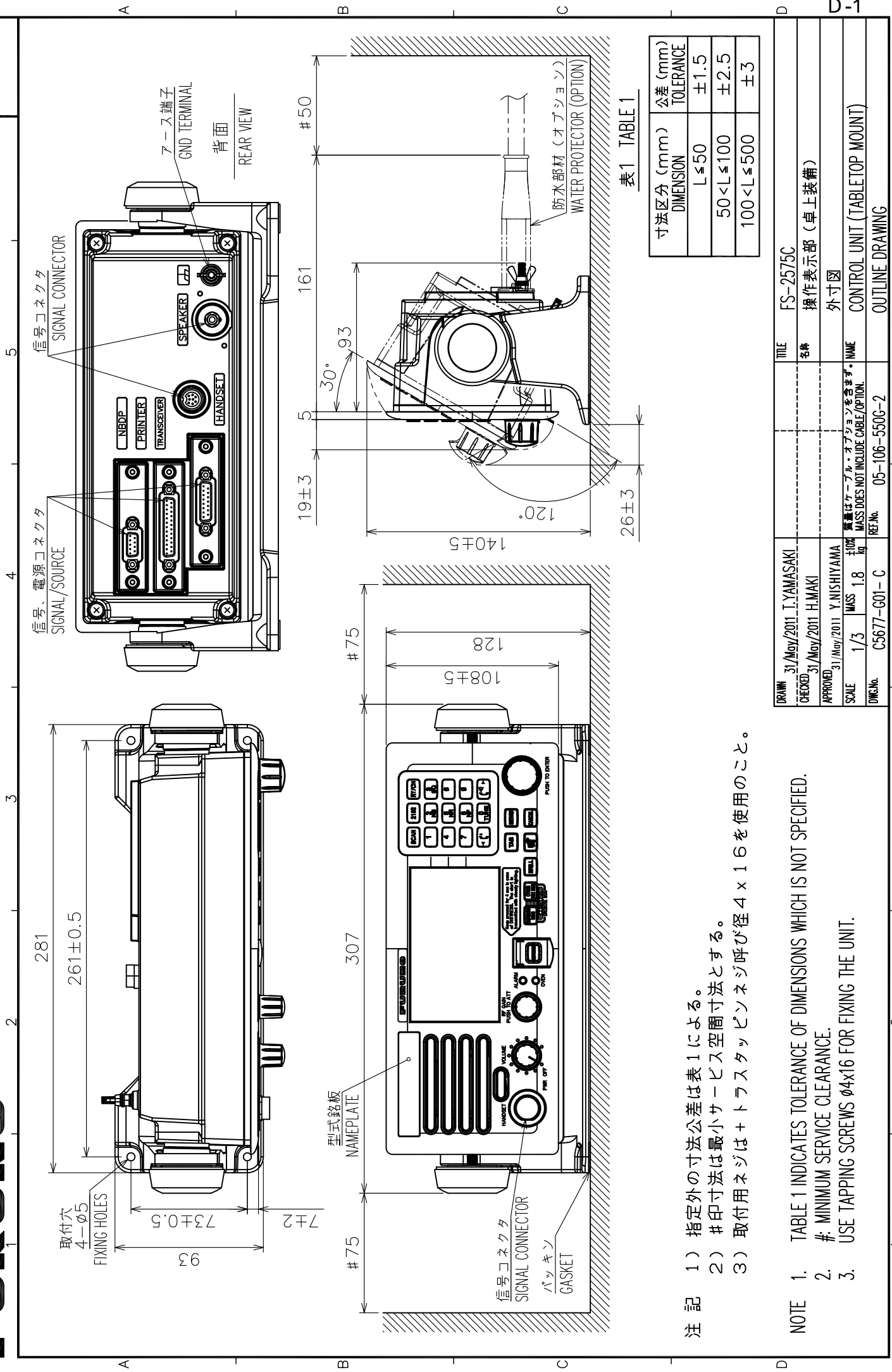

- 注記
- 1) 指定外の寸法公差は表1による。
  - 2) #印寸法は最小サービスマン間寸法とする。
  - 3) 取付用ネジは+トラスチックピンネジ呼び径4×16を使用のこと。

- NOTE
1. TABLE 1 INDICATES TOLERANCE OF DIMENSIONS WHICH IS NOT SPECIFIED.
  2. #: MINIMUM SERVICE CLEARANCE.
  3. USE TAPPING SCREWS φ4x16 FOR FIXING THE UNIT.

DRAWN	31/May/2011	T. YAMASAKI	TITLE	FS-2575C
CHECKED	31/May/2011	H. MAKI	名称	操作表示部 (卓上装備)
APPROVED	31/May/2011	Y. NISHIYAMA	外寸図	
SCALE	1/3	質量はケーブル・オプションを含みず。 MASS DOES NOT INCLUDE CABLE/OPTION.	NAME	CONTROL UNIT (TABLETOP MOUNT)
DWG.No.	C5677-001-C	REF.No.	05-106-550G-2	OUTLINE DRAWING

表 1 TABLE 1

寸法区分 (mm) DIMENSION	公差 (mm) TOLERANCE
L ≤ 50	±1.5
50 < L ≤ 100	±2.5
100 < L ≤ 500	±3

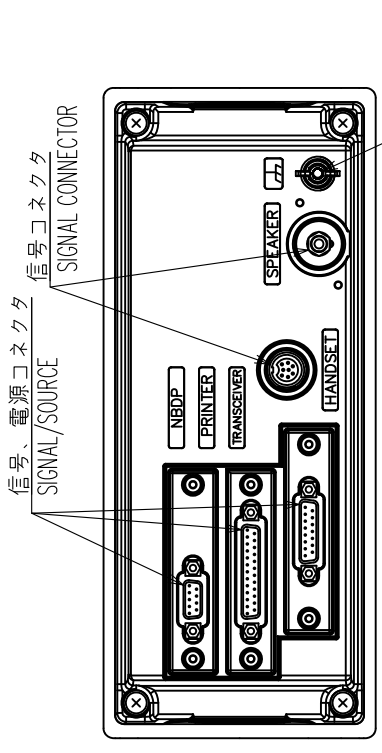

背面  
REAR VIEW

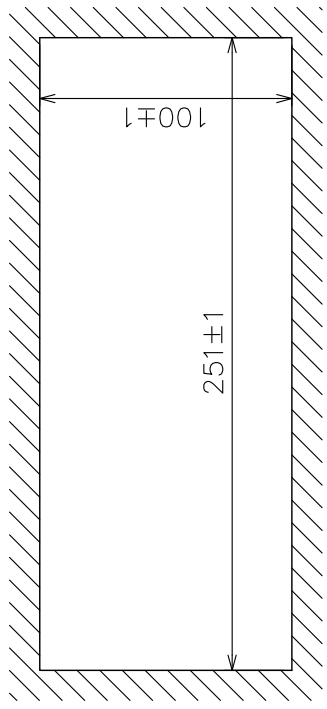
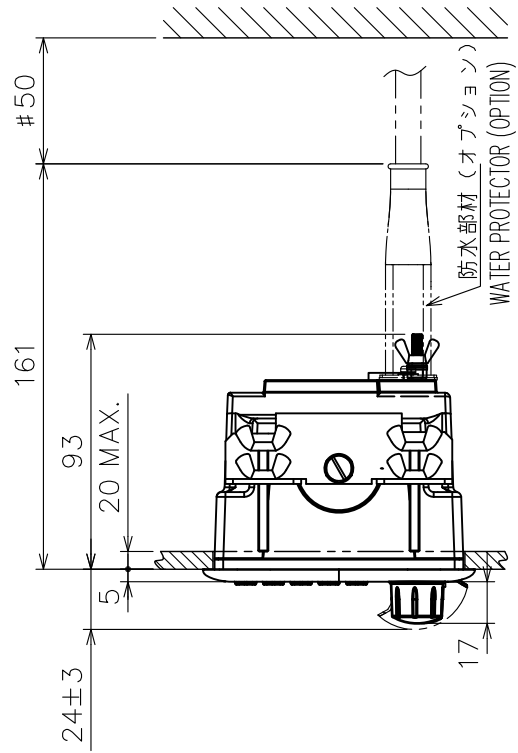

取付穴寸法 (参考図)  
CUTOOUT DIMENSIONS (FOR REFERENCE)

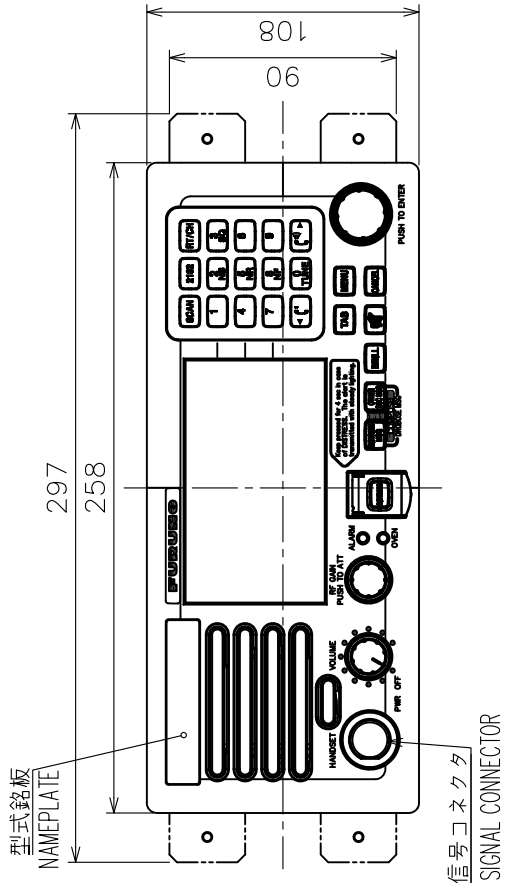

- 注 記 1) 指定外の寸法公差は表 1 による。  
 2) # 印寸法は最小サービスマン間寸法とする。  
 3) 壁の厚さは最大20mmとする。

- NOTE 1. TABLE 1 INDICATES TOLERANCE OF DIMENSIONS WHICH IS NOT SPECIFIED.  
 2. # MINIMUM SERVICE CLEARANCE.  
 3. BULKHEAD THICKNESS: 20mm MAX.

DRAWN	25/May/2011 T.YAMASAKI	TITLE	FS-2375C
CHECKED	26/May/2011 H.IMAKI	名称	操作表示部 (埋込装置)
APPROVED	27/May/2011 Y.NISHIYAMA	外寸図	
SCALE	1/3 MASS 1.8 kg	質量はケーブル・オプションを含みず。 (MASS DOES NOT INCLUDE CABLE/OPTION.)	CONTROL UNIT (FLUSH MOUNT)
DMC.No.	C5677-G02-B	REF.No.	05-106-551G-1

表1 TABLE 1

寸法区分 (mm) DIMENSION	公差 (mm) TOLERANCE
$L \leq 50$	$\pm 1.5$
$50 < L \leq 100$	$\pm 2.5$
$100 < L \leq 500$	$\pm 3$

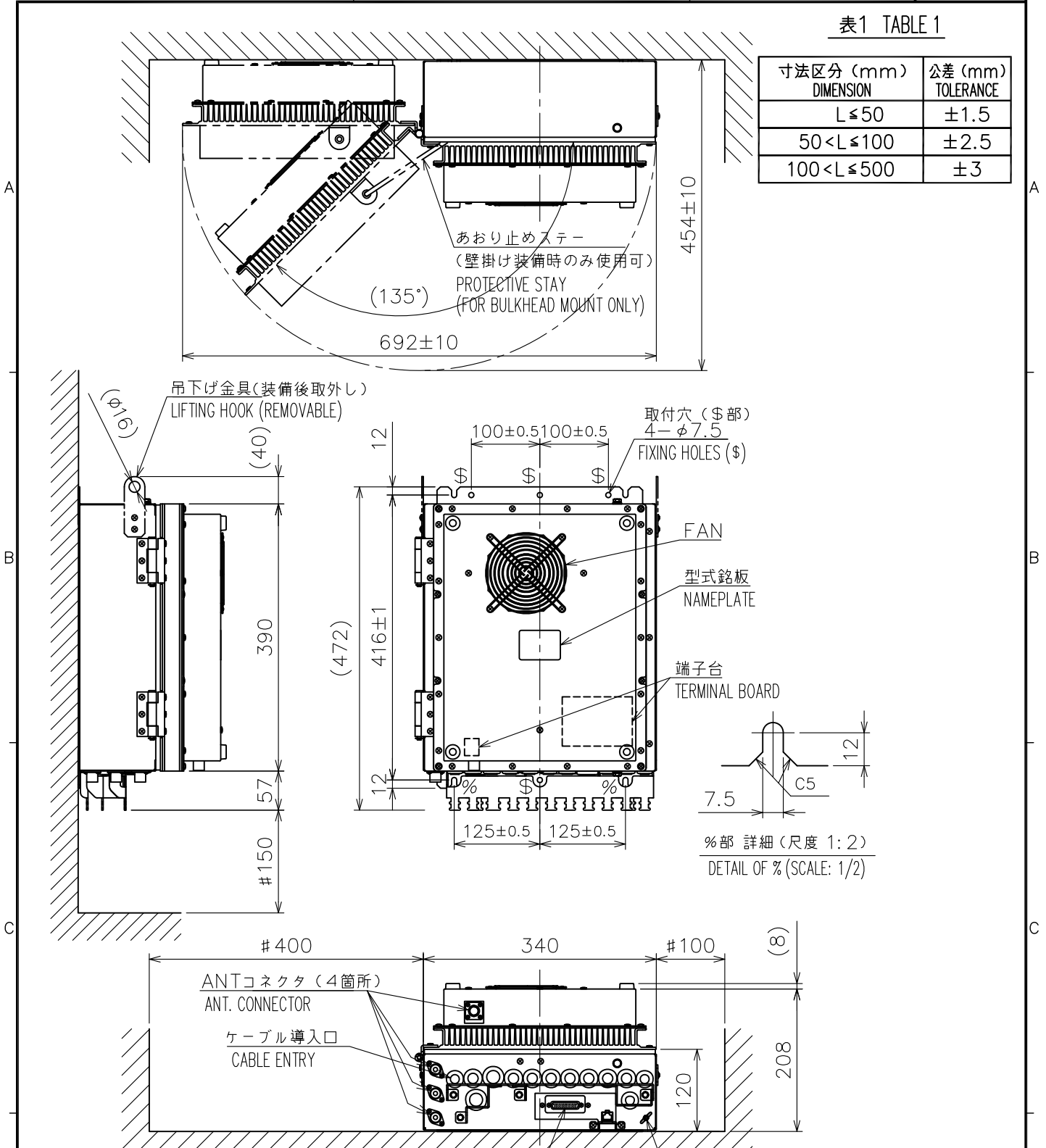

- 注記 1) 指定外の寸法公差は表1による。  
 2) #印寸法は最小サービス空間寸法とする。  
 3) 取付用ネジは+トラスタップネジ  $6 \times 30$  を使用のこと。
- NOTE 1. TABLE 1 INDICATES TOLERANCE OF DIMENSIONS WHICH IS NOT SPECIFIED.  
 2. #: MINIMUM SERVICE CLEARANCE.  
 3. USE TAPPING SCREWS  $\phi 6 \times 30$  FOR FIXING THE UNIT.

DRAWN 16/Mar/2012 T.YAMASAKI	TITLE FS-1575T
CHECKED 16/Mar/2012 H.MAKI	名称 送受信部
APPROVED 16/Mar/2012 Y.NISHIYAMA	FS-1575 外寸図
SCALE 1/8	MASS 16 $\pm 10\%$ kg
DWG. No. C5676-G03-A	REF. No. 05-106-252G-0
NAME TRANSCEIVER UNIT OUTLINE DRAWING	

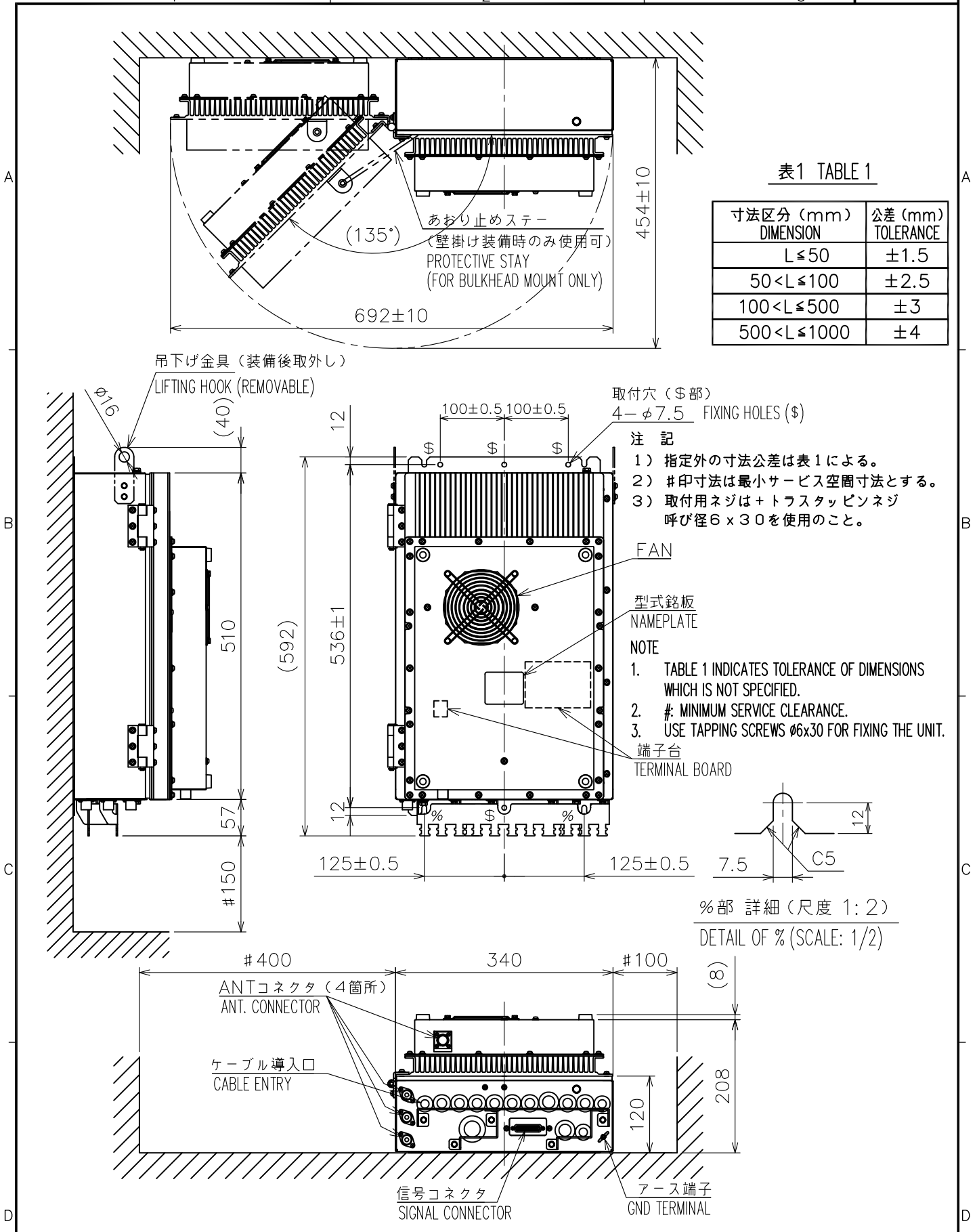

DRAWN 26/Apr/2011 I.YAMASAKI	TITLE FS-2575T
CHECKED 26/Apr/2011 H.MAKI	名称 送受信部
APPROVED 26/Apr/2011 D.MILLS	FS-2575 外寸図
SCALE 1/8	MASS 20 ±10% kg
DWG. No. C5677-G03-A	REF. No. 05-106-251G-0
NAME TRANSCEIVER UNIT OUTLINE DRAWING	

表1 TABLE 1

寸法区分 (mm) DIMENSION	公差 (mm) TOLERANCE
$L \leq 50$	$\pm 1.5$
$50 < L \leq 100$	$\pm 2.5$
$100 < L \leq 500$	$\pm 3$
$500 < L \leq 1000$	$\pm 4$

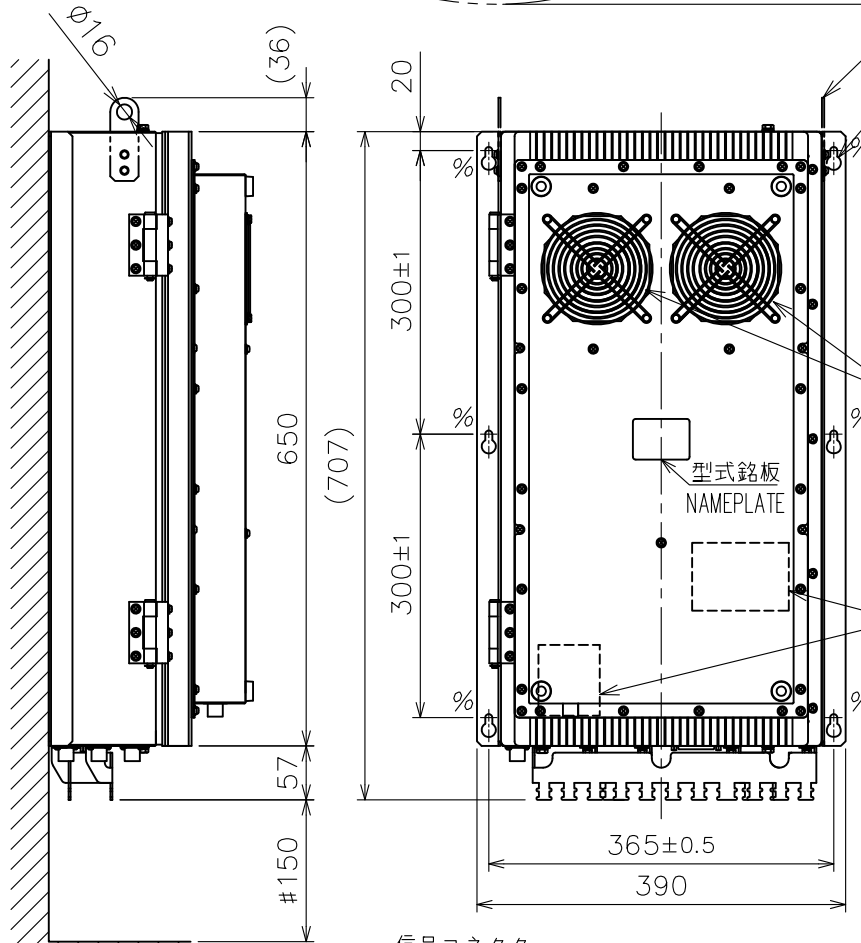
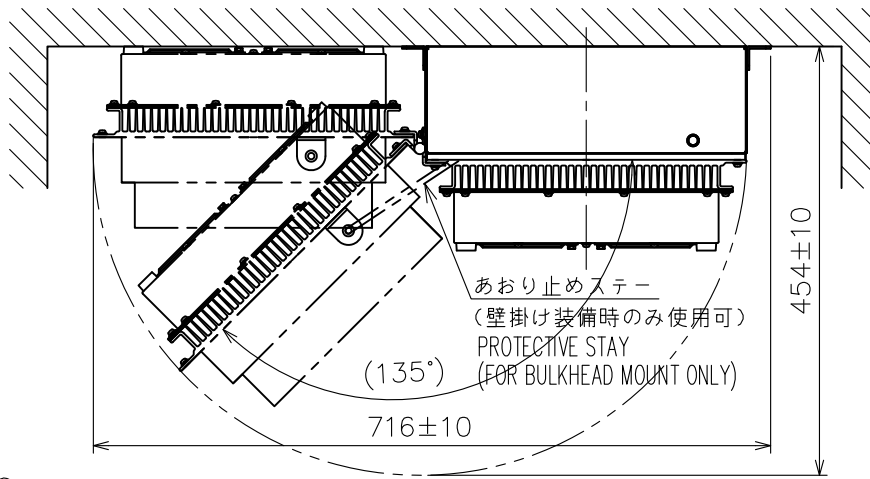

注記

- 1) 指定外の寸法公差は表1による。
- 2) #印寸法は最小サービス空間寸法とする。
- 3) 取付用ネジは+トラスタップネジ  
呼び径6×30を使用のこと。

NOTE

1. TABLE 1 INDICATES TOLERANCE OF DIMENSIONS WHICH IS NOT SPECIFIED.
2. #: MINIMUM SERVICE CLEARANCE.
3. USE TAPPING SCREWS  $\phi 6 \times 30$  FOR FIXING THE UNIT.

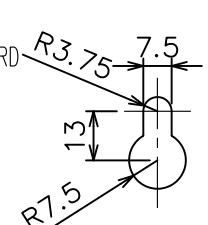

φ部 詳細 (尺度 1:2)  
DETAIL FOR φ (SCALE: 1/2)

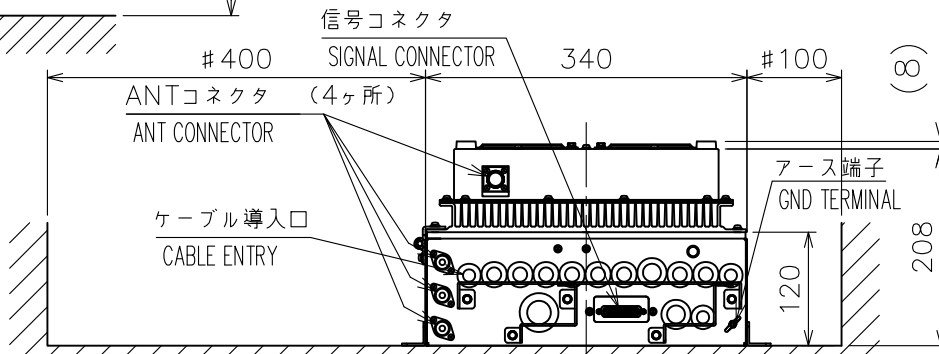

DRAWN	22/Apr/2011 I.YAMASAKI	TITLE	FS-5075T
CHECKED	22/Apr/2011 H.MAKI	名称	送受信部
APPROVED	26/Apr/2011 D.MILLS	FS-5075	外寸図
SCALE	1/8	MASS	27 ±10% kg
DWG. No.	C5678-G02-A	REF. No.	05-106-250G-0
		NAME	TRANSCEIVER UNIT OUTLINE DRAWING

表 1 TABLE 1

寸法区分 (mm) DIMENSIONS	公差 (mm) TOLERANCE
L ≤ 50	± 1.5
50 < L ≤ 100	± 2.5
100 < L ≤ 500	± 3

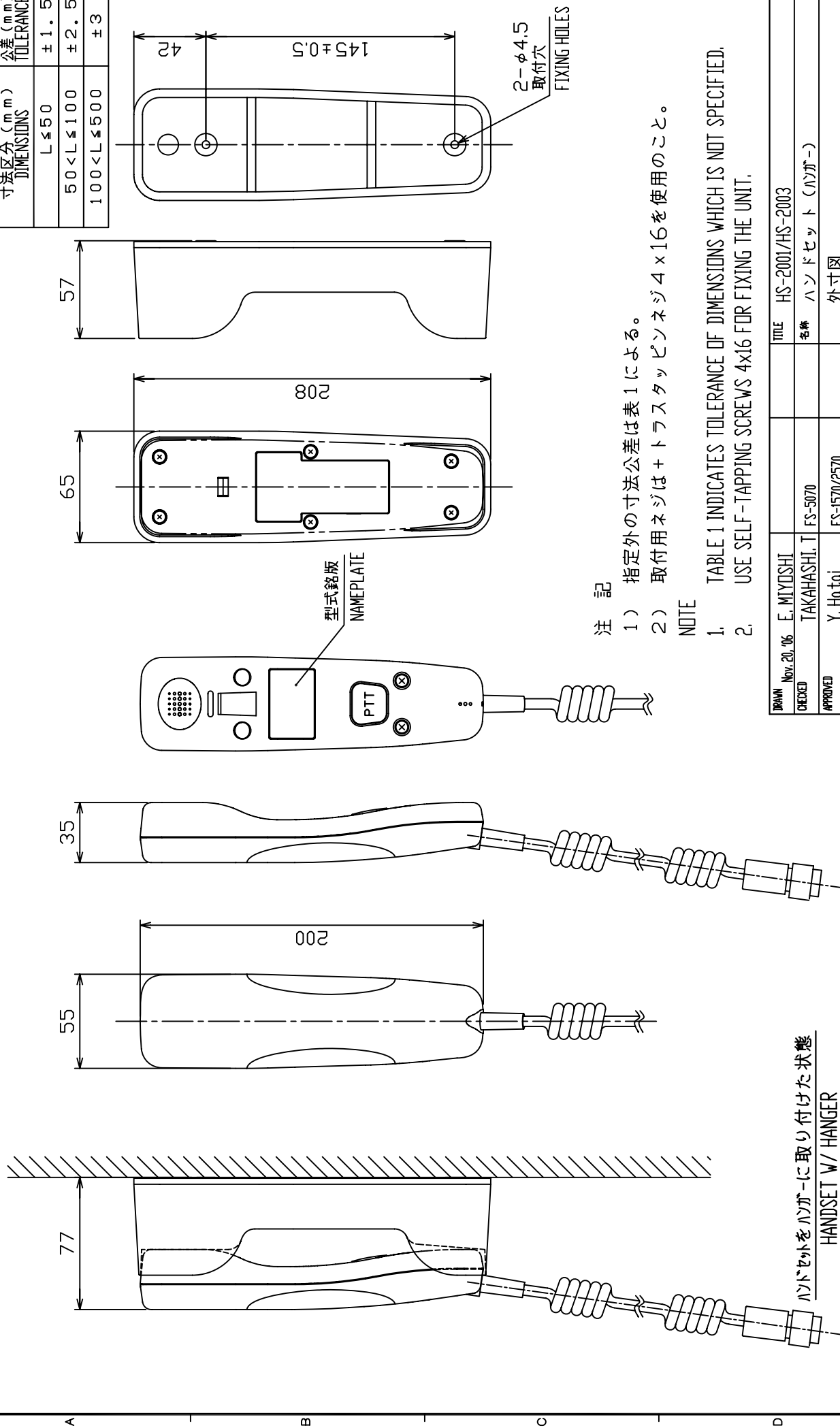

注 記

- 1) 指定外の寸法公差は表 1 による。
- 2) 取付用ネジは + トラスタップピンネジ 4 × 16 を使用のこと。

NOTE

1. TABLE 1 INDICATES TOLERANCE OF DIMENSIONS WHICH IS NOT SPECIFIED.
2. USE SELF-TAPPING SCREWS 4x16 FOR FIXING THE UNIT.

DRAWN	Nov. 20, '06	E. MIYOSHI	TITLE	HS-2001/HS-2003
CHECKED		TAKAHASHI, T	名称	ハンドセット (ハンガ-)
APPROVED		Y. Hattai	外寸図	
SCALE	1/3	質量はケーブル・ハンガ-を含む。 MASS W/ CABLE AND HANGER.	NAME	HANDSET / HANGER
DMG No.		CS636-G04-E		OUTLINE DRAWING

ハンドセットをハンガ-に取り付けた状態  
HANDSET W/ HANGER

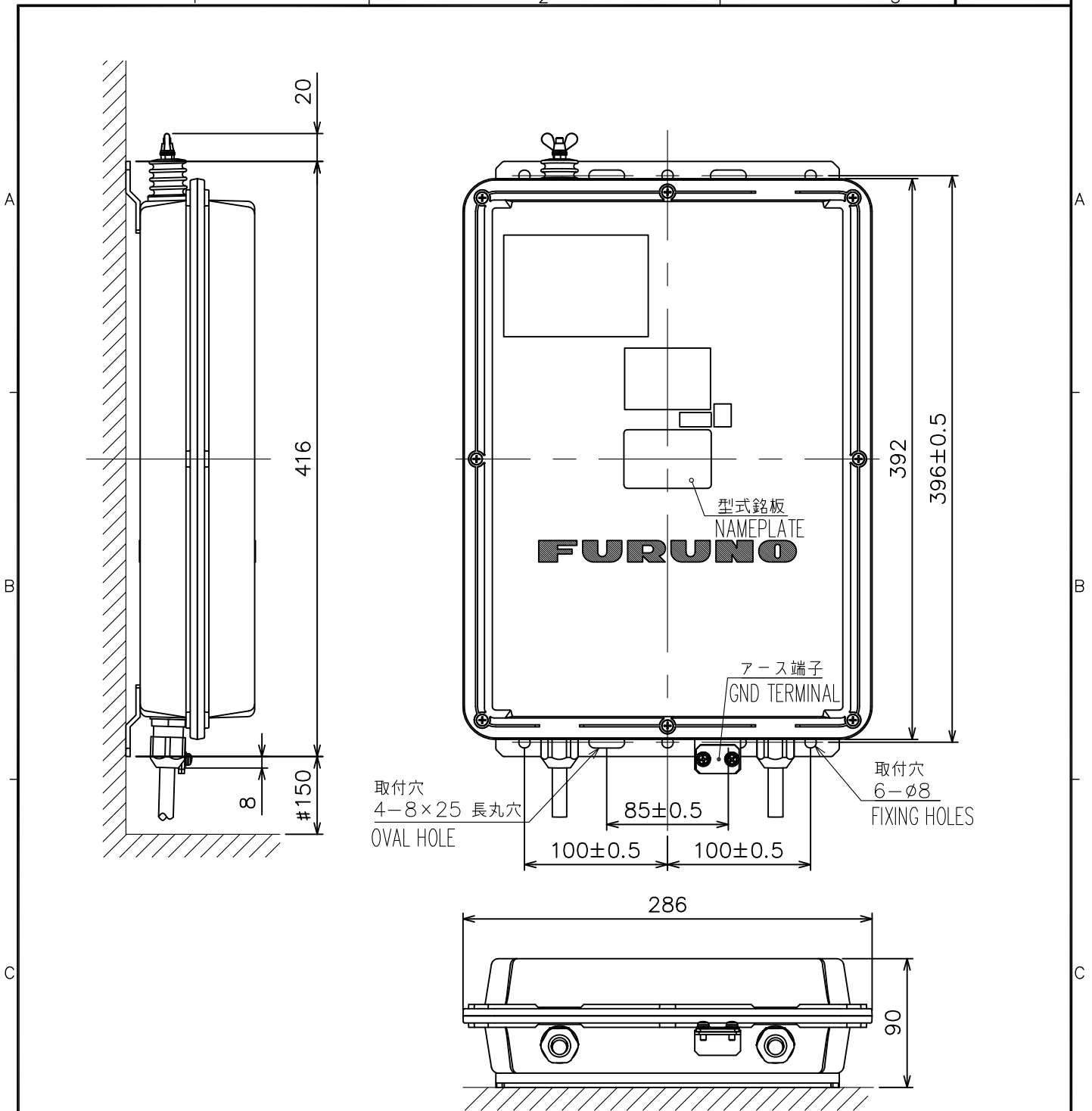

### 注 記

- 1) 指定外の寸法公差は表 1 による。
- 2) # 印寸法は最小サービス空間寸法とする。
- 3) 取付用ネジは M6 ボルトを使用のこと。

### NOTE

1. TABLE 1 INDICATES TOLERANCE OF DIMENSIONS WHICH IS NOT SPECIFIED.
2. #: MINIMUM SERVICE CLEARANCE.
3. USE M6 BOLTS FOR FIXING THE UNIT.

表 1 TABLE 1

寸法区分 (mm) DIMENSION	公差 (mm) TOLERANCE
$L \leq 50$	$\pm 1.5$
$50 < L \leq 100$	$\pm 2.5$
$100 < L \leq 500$	$\pm 3$

DRAWN 20/Jan/2012 T.YAMASAKI		TITLE AT-1575 (AES)
CHECKED 20/Jan/2012 H.MAKI		名称 アンテナカプラ
APPROVED 20/Jan/2012 Y.NISHIYAMA	FS-1575	外寸図
SCALE 1/4	MASS 2.6 ±10% kg	NAME ANTENNA COUPLER
DWG. No. C5676-G01-A	REF. No. 05-106-351G-0	OUTLINE DRAWING



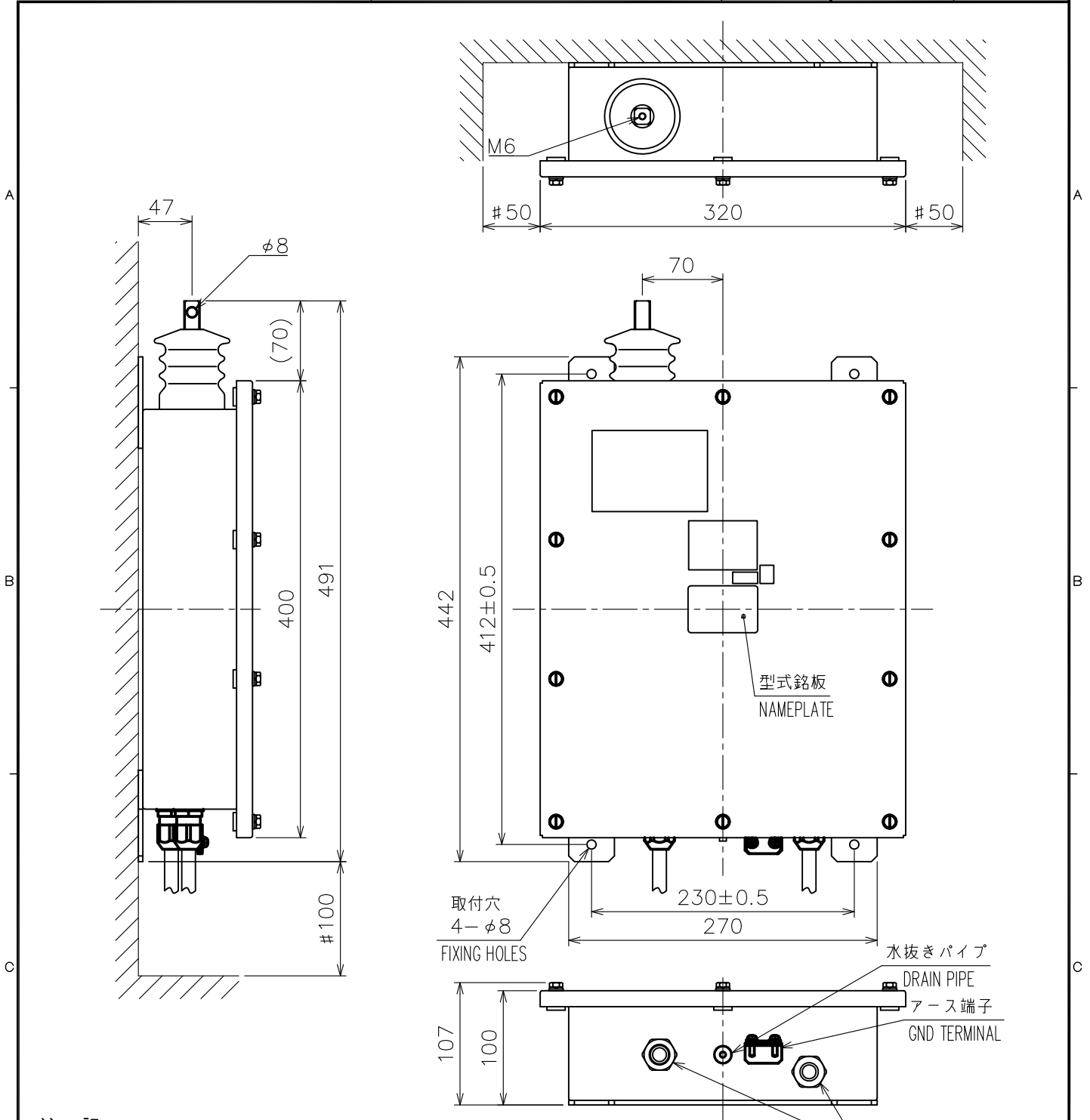

注 記

- 1) 指定外の寸法公差は表 1 による。
- 2) # 印寸法は最小サービス空間寸法とする。
- 3) 取付用ネジは M6 ボルトを使用のこと。

NOTE

1. TABLE 1 INDICATES TOLERANCE OF DIMENSIONS WHICH IS NOT SPECIFIED.
2. #: MINIMUM SERVICE CLEARANCE.
3. USE M6 BOLTS FOR FIXING THE UNIT.

表 1 TABLE 1

寸法区分 (mm) DIMENSION	公差 (mm) TOLERANCE
$L \leq 50$	$\pm 1.5$
$50 < L \leq 100$	$\pm 2.5$
$100 < L \leq 500$	$\pm 3$

DRAWN 20/Jan/2012 T.YAMASAKI	TITLE AT-1575 (SUS)
CHECKED 20/Jan/2012 H.MAKI	名称 アンテナカプラ
APPROVED 20/Jan/2012 Y.NISHIYAMA	FS-1575 外寸図
SCALE 1/5	MASS 8.8 $\pm 10\%$ kg
DWG. No. C5676-G02-A	REF. No. 05-106-352G-0
NAME ANTENNA COUPLER OUTLINE DRAWING	

表1 TABLE 1

寸法区分 (mm) DIMENSION	公差 (mm) TOLERANCE
$L \leq 50$	$\pm 1.5$
$50 < L \leq 100$	$\pm 2.5$
$100 < L \leq 500$	$\pm 3$
$500 < L \leq 1000$	$\pm 4$

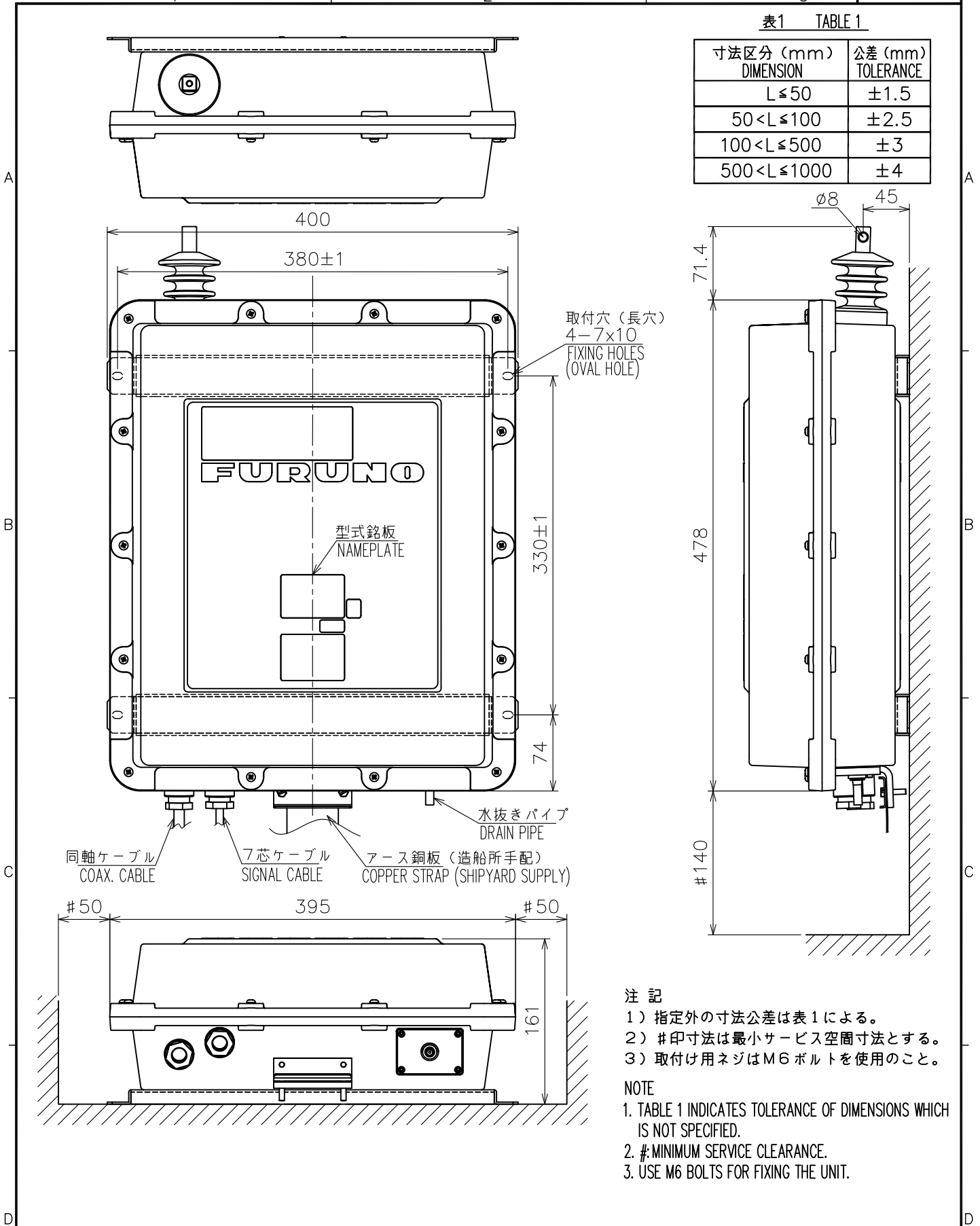

注記

- 1) 指定外の寸法公差は表1による。
- 2) #印寸法は最小サービス空間寸法とする。
- 3) 取付け用ネジはM6ボルトを使用のこと。

NOTE

1. TABLE 1 INDICATES TOLERANCE OF DIMENSIONS WHICH IS NOT SPECIFIED.
2. #: MINIMUM SERVICE CLEARANCE.
3. USE M6 BOLTS FOR FIXING THE UNIT.

DRAWN	1/Aug/2013 I.YAMASAKI	TITLE	AT-5075
CHECKED	1/Aug/2013 H.MAKI	名称	アンテナカプラ
APPROVED	1/Aug/2013 H.MAKI	FS-2575/5075	外寸図
SCALE	1/5	MASS	9.2 ±10% kg
DWG. No.	C5678-G01-B	REF. No.	05-106-350G-3
		NAME	ANTENNA COUPLER
			OUTLINE DRAWING

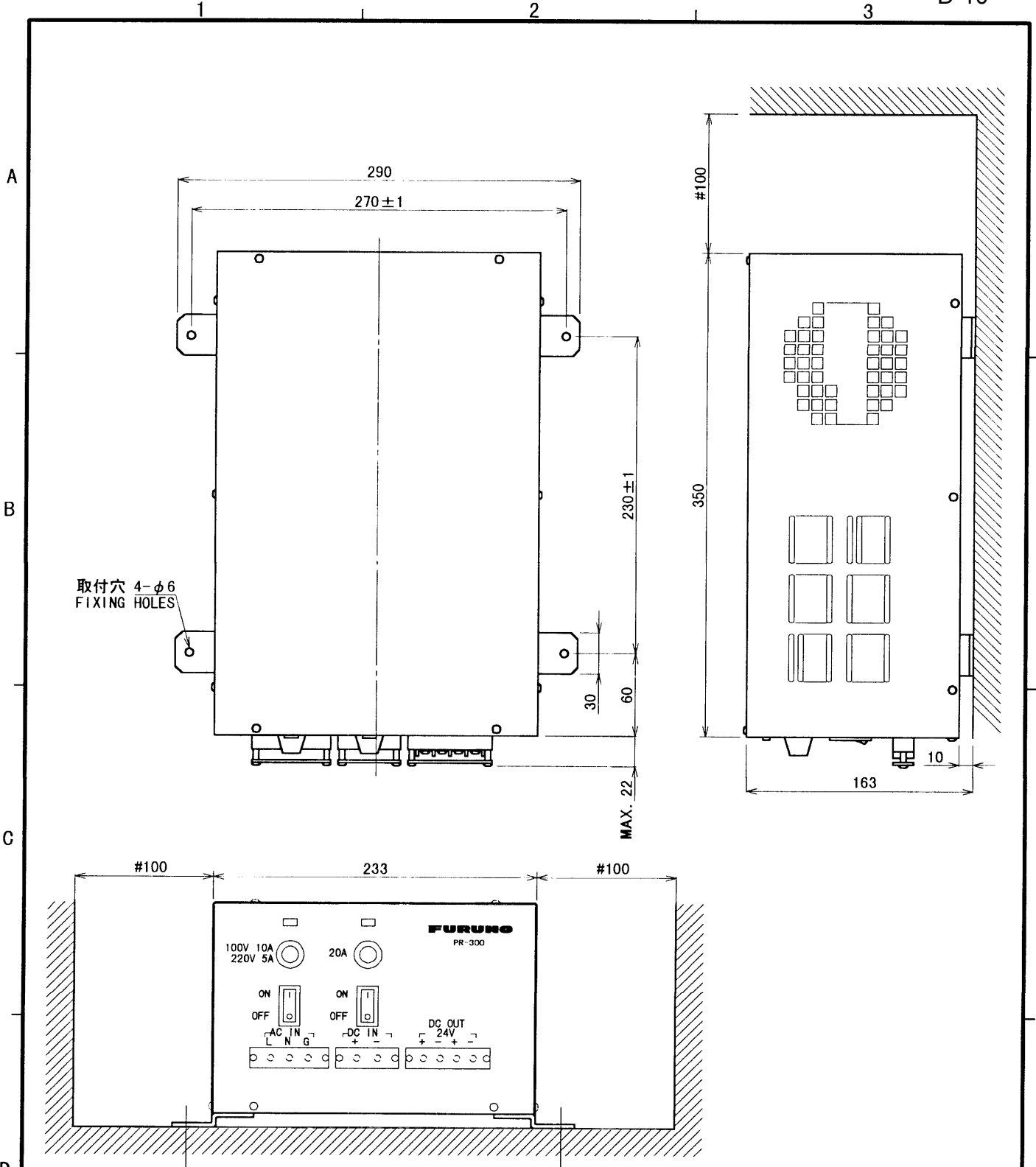

注記

- 1) #: 推奨する最小サービス空間寸法。
- 2) 指定なき寸法公差は表1による。

NOTE:

1. #: RECOMMENDED SERVICE CLEARANCE.
2. TABLE 1 INDICATES TOLERANCE OF DIMENSIONS.

表1 TABLE 1

寸法範囲 (mm) DIMENSION	公差 (mm) TOLERANCE
0 < L ≤ 50	±1.5 mm
50 < L ≤ 100	±2.5 mm
100 < L ≤ 500	±3 mm

DRAWN <i>June 19 '60 T. YAMASAE</i>		TITLE PR-300
CHECKED <i>June 19 '60 Y. Kuroki</i>		名称 AC-DC電源ユニット
APPROVED <i>June 19 '60 Y. Kuroki</i>		外寸図
SCALE 1/4	MASS ±10% 14.5 kg	NAME AC-DC POWER SUPPLY UNIT
DWG. No. C5003-G02-D		OUTLINE DRAWING

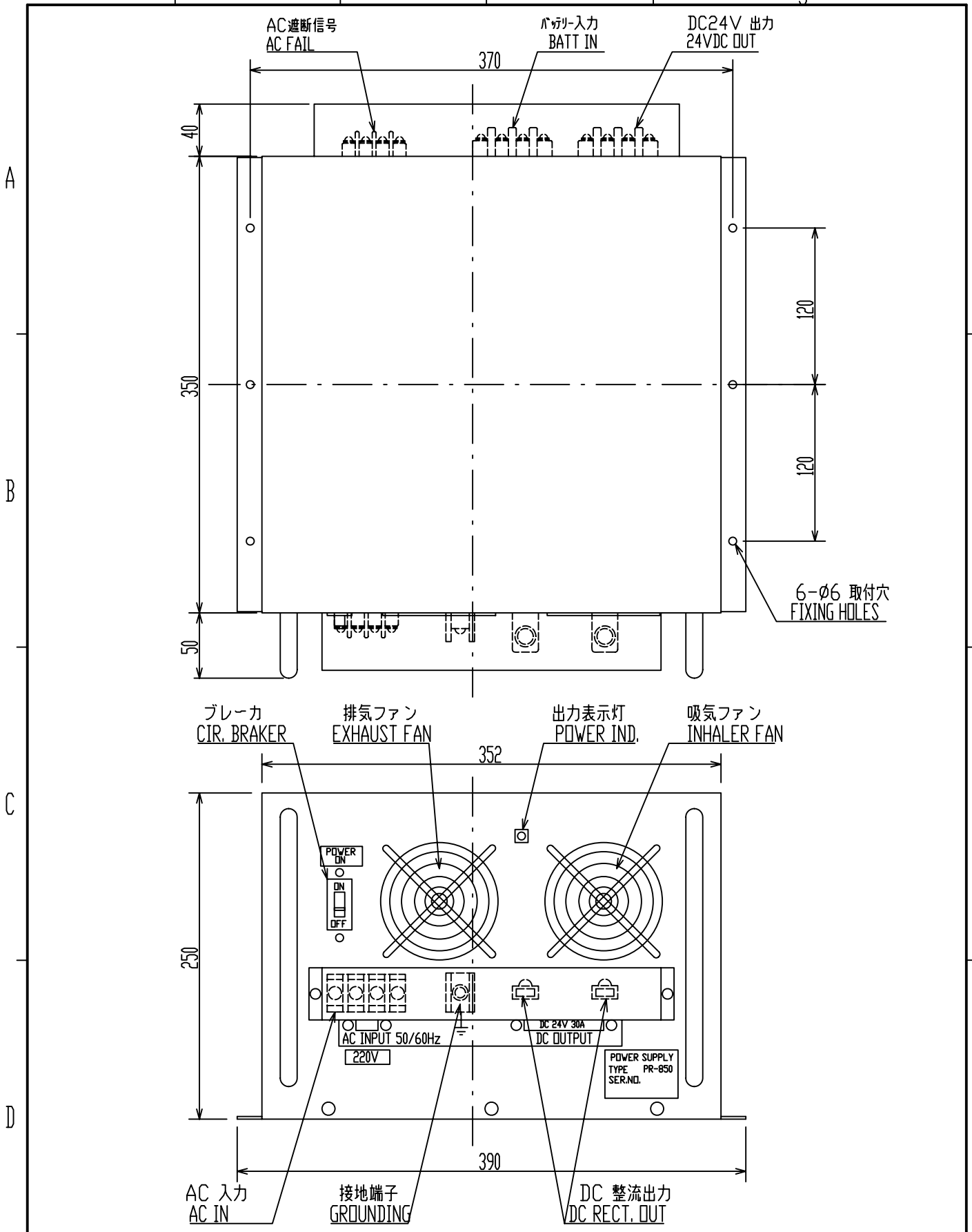

DRAWN	Nov. 25, '06	E. MIYOSHI	TITLE	PR-850A
CHECKED		TAKAHASHI.T	名称	AC-DC電源ユニット
APPROVED		Y. Hatai		外寸図
SCALE	1/4	MASS 35 ±10% kg	NAME	AC-DC POWER SUPPLY UNIT
DWG.No.	C5519-G11-G	REF.No.		OUTLINE DRAWING

4

3

表1 TABLE 1

寸法区分 (mm) DIMENSION	公差 (mm) TOLERANCE
L ≤ 50	±1.5
50 < L ≤ 100	±2.5
100 < L ≤ 500	±3

- 注記 1) 指定外の寸法公差は表1による。  
 2) #印寸法は最小サービスペース寸法とする。  
 3) 取付用ネジはトラスタツピンネジ呼び径5×20を使用のこと。
- NOTE 1. TABLE 1 INDICATES TOLERANCE OF DIMENSIONS WHICH IS NOT SPECIFIED.  
 2. # MINIMUM SERVICE CLEARANCE.  
 3. USE TAPPING SCREWS  $\phi 5 \times 20$  FOR FIXING THE UNIT.

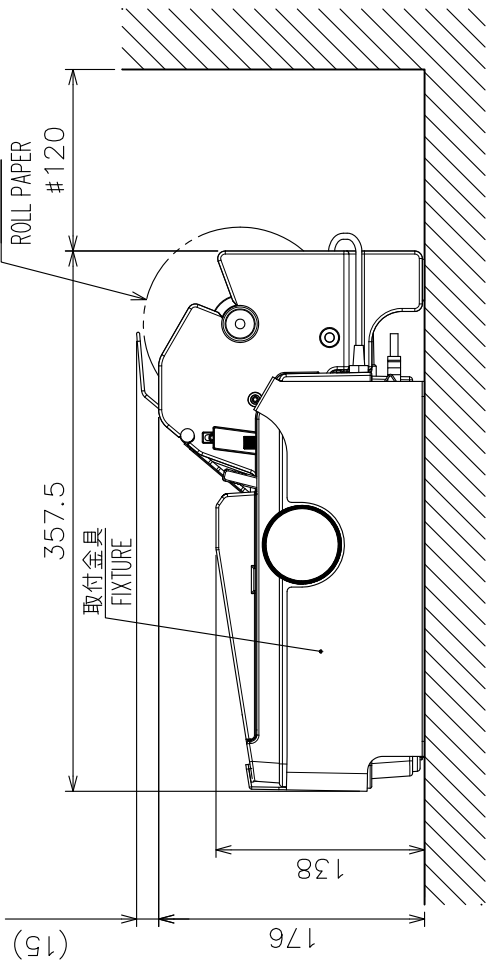
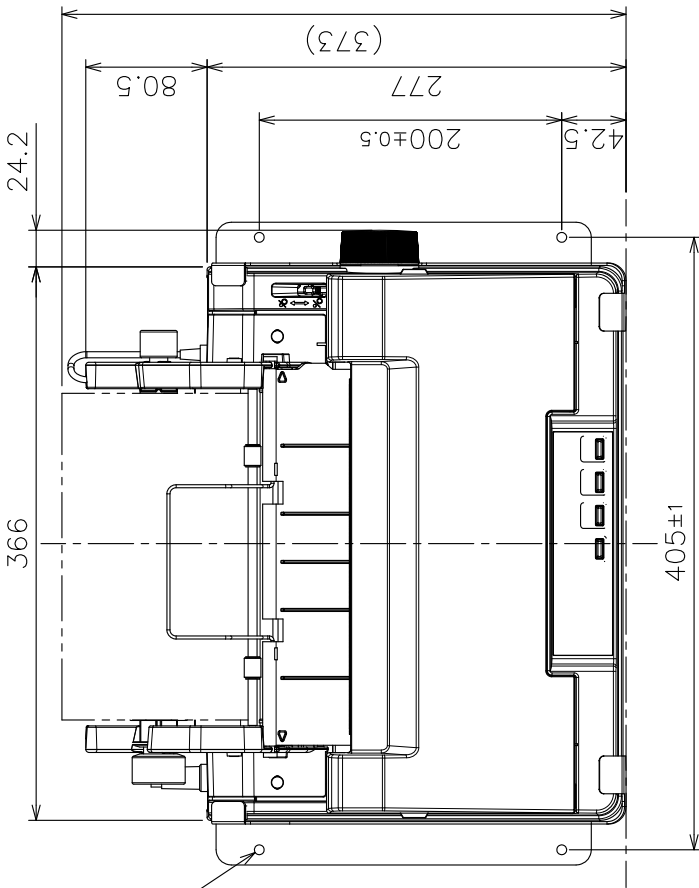

DRAWN	6/Jul/2012 I.YAMASAKI	TITLE	PP-520	
CHECKED	6/Jul/2012 H.MAKI	名#	プリンタ	
APPROVED	6/Jul/2012 Y.NISHIYAMA	外寸図		
SCALE	1/5 MASS 5.5 kg	質量はロール紙を含まず MASS DOES NOT INCLUDE ROLL PAPER	NAME	PRINTER
DWG.No.	C5080-G02-A	REF.No.	16-023-551G-1	OUTLINE DRAWING

A

B

C

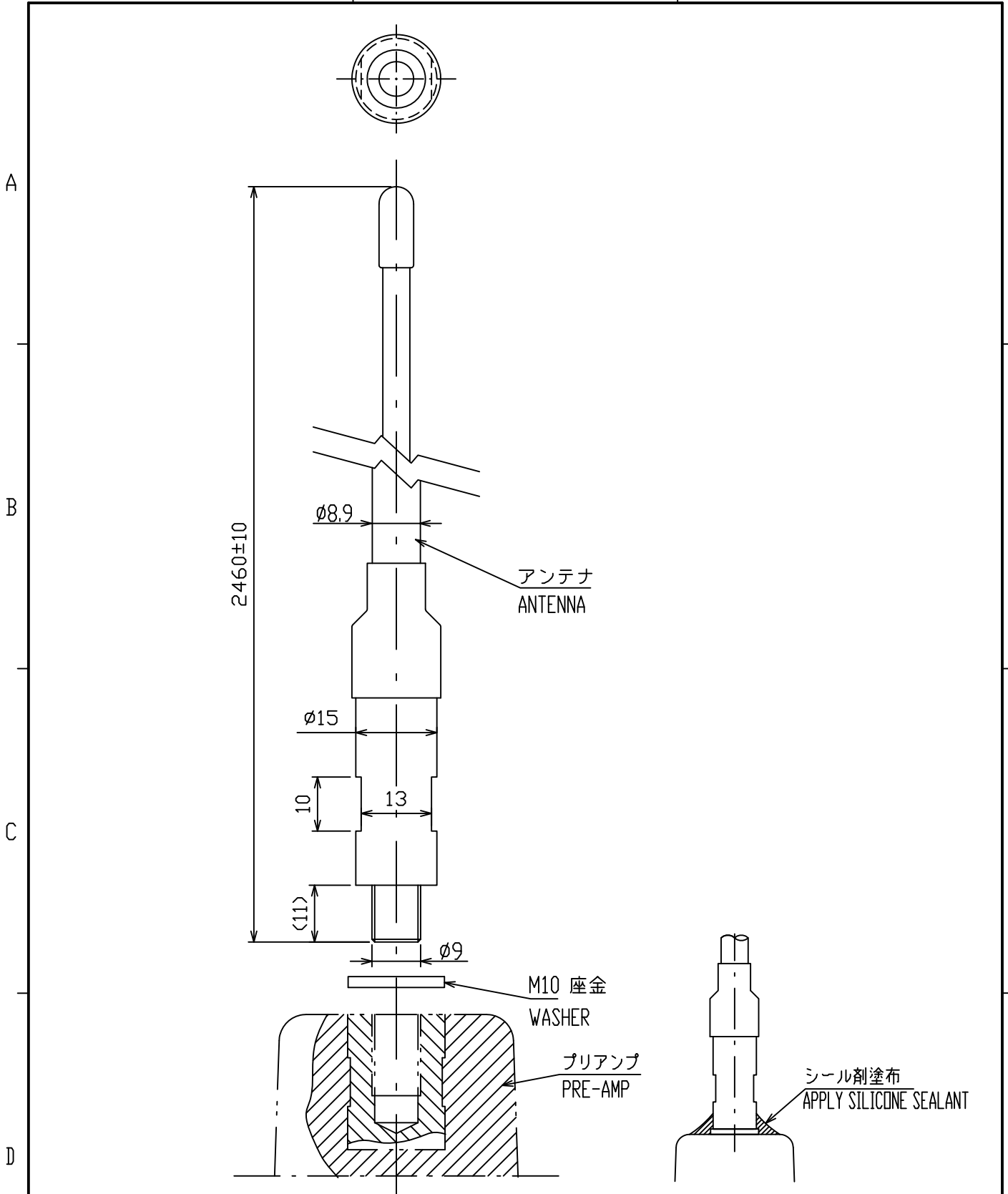

注記 締付けはトルクレンチを使用してください。(25.0±5% N・m)

NOTE USE A TORQUE WRENCH FOR FASTENING W/ 25.0±5% [N・m].

DRAWN	28/Jan/2014	T.YAMASAKI	TITLE	04S4176
CHECKED	28/Jan/2014	H.MAKI	名称	2.6m ホイップアンテナ
APPROVED	28/Jan/2014	H.MAKI	外寸図	
SCALE	1/1	MASS	0.5 ±10%	NAME
			kg	2.6m WHIP ANTENNA
DWG.No.	C4002-018- K		REF.No.	OUTLINE DRAWING

表 1 TABLE 1

寸法範囲 (mm) DIMENSIONS	公差(mm) TOLERANCE
$L \leq 50$	$\pm 1.5$
$50 < L \leq 100$	$\pm 2.5$
$100 < L \leq 500$	$\pm 3$

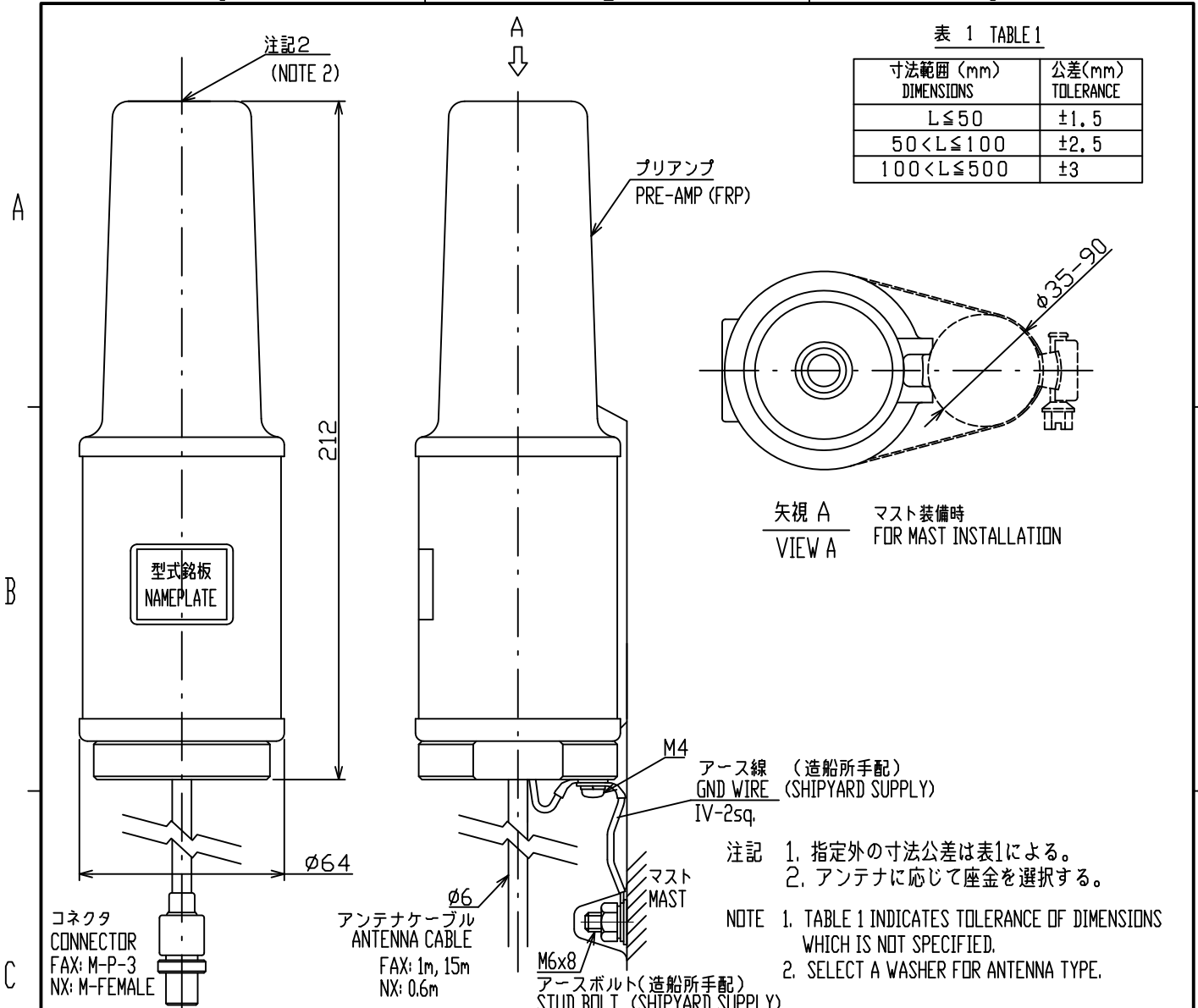

マストへの取付  
MAST MOUNTING

パイプ装備  
FIXING TO PIPE

ホイップアンテナの場合  
FOR WHIP ANTENNA

マスト装備  
FIXING TO MAST

アンテナワイヤの場合  
FOR ANTENNA WIRE

アンテナ取付ネジ  
COUPLING SCREW

アンテナワイヤ  
ANTENNA WIRE

アンテナワイヤ取付金具  
ANTENNA WIRE FIXTURE

ウィット細目ネジ  
WHITWORTH FINE  
SCREW THREADS  
(W25-14)

テープを巻く  
WIND TAPE

LEAVE SLACK HERE NOT  
TO STRESS ON CONNECTOR.  
コネクタにストレスを与えないよう  
余裕を持たせること

シール剤で固定  
APPLY SILICONE SEALANT

ボルト  
M6x8 BOLT

パーカークランプ  
HOSE CLAMP

ケーブルタイ (LOCAL SUPPLY)  
ケーブル固定バンド (現地手配)

パイプ (造船所手配) φ27.2  
PIPE (SHIPYARD SUPPLY)

アンテナケーブル  
ANTENNA CABLE

注記 装備前にパイプをプリアンプにねじ込むこと。  
NOTE FASTEN PIPE TO ANTENNA BEFORE INSTALLATION.

DRAWN 5/Mar/2020 T.YAMASAKI

CHECKED 5/Mar/2020 H.MAKI

APPROVED 6/Mar/2020 H.MAKI

SCALE 1/2 MASS 0.6 ±10% kg

DWG.No. C6244-003-Q

TITLE FAX-5, NX-5/6

名称 プリアンプ

外寸図

NAME PRE-AMP UNIT

OUTLINE DRAWING

質量はケーブルを含まず。  
MASS DOES NOT INCLUDE CABLE.  
REF.No.

表1 TABLE 1

寸法区分(mm) DIMENSIONS	公差(mm) TOLERANCE
0 < L ≤ 50	±1.5
50 < L ≤ 100	±2.5
100 < L ≤ 500	±3

A

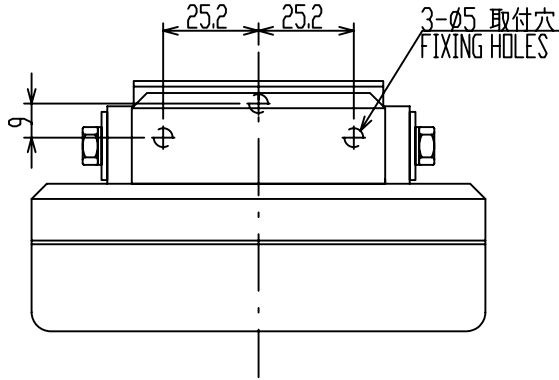

B

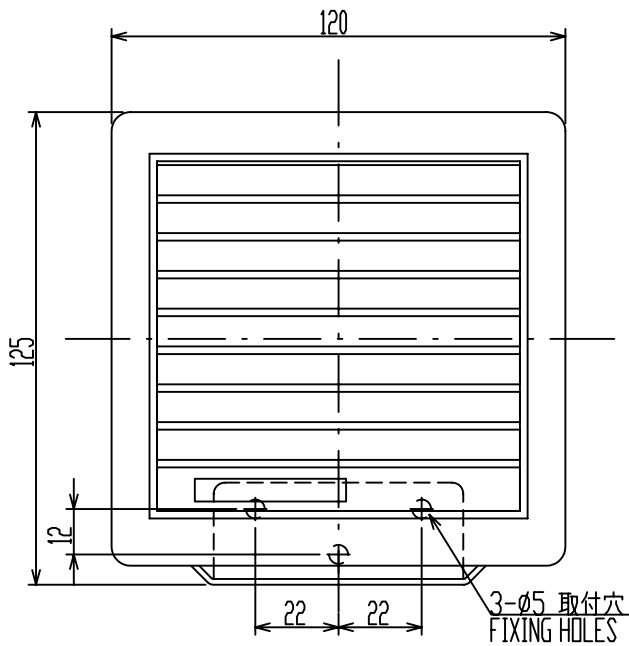

C

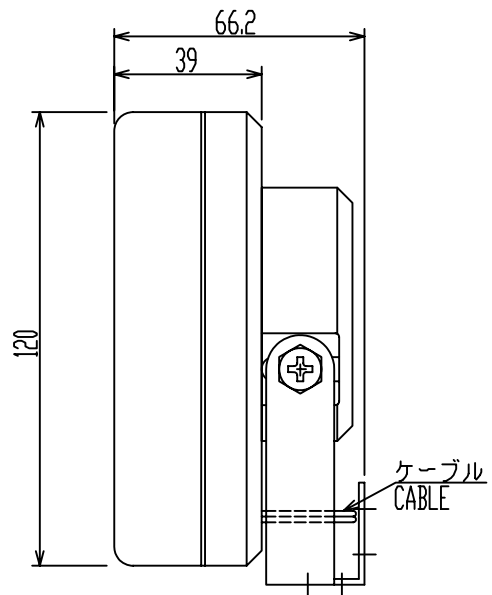

D

注記 1 ) 指定外寸公差は表1による。

NOTE 1. TABLE 1 INDICATES TOLERANCE OF DIMENSIONS WHICH IS NOT SPECIFIED.

DRAWN	Nov. 25, '06	E. MIYOSHI	TITLE	SEM-21Q
CHECKED		TAKAHASHI, T	名称	スピーカ
APPROVED		Y. Hatai		外寸図
SCALE	1/2	MASS 0.54 ±10% kg	質量は2.8mケーブルを含む MASS W/ 2.8m CABLE	NAME
DWG.No.	C5016-G07-C		REF.No.	LOUDSPEAKER OUTLINE DRAWING



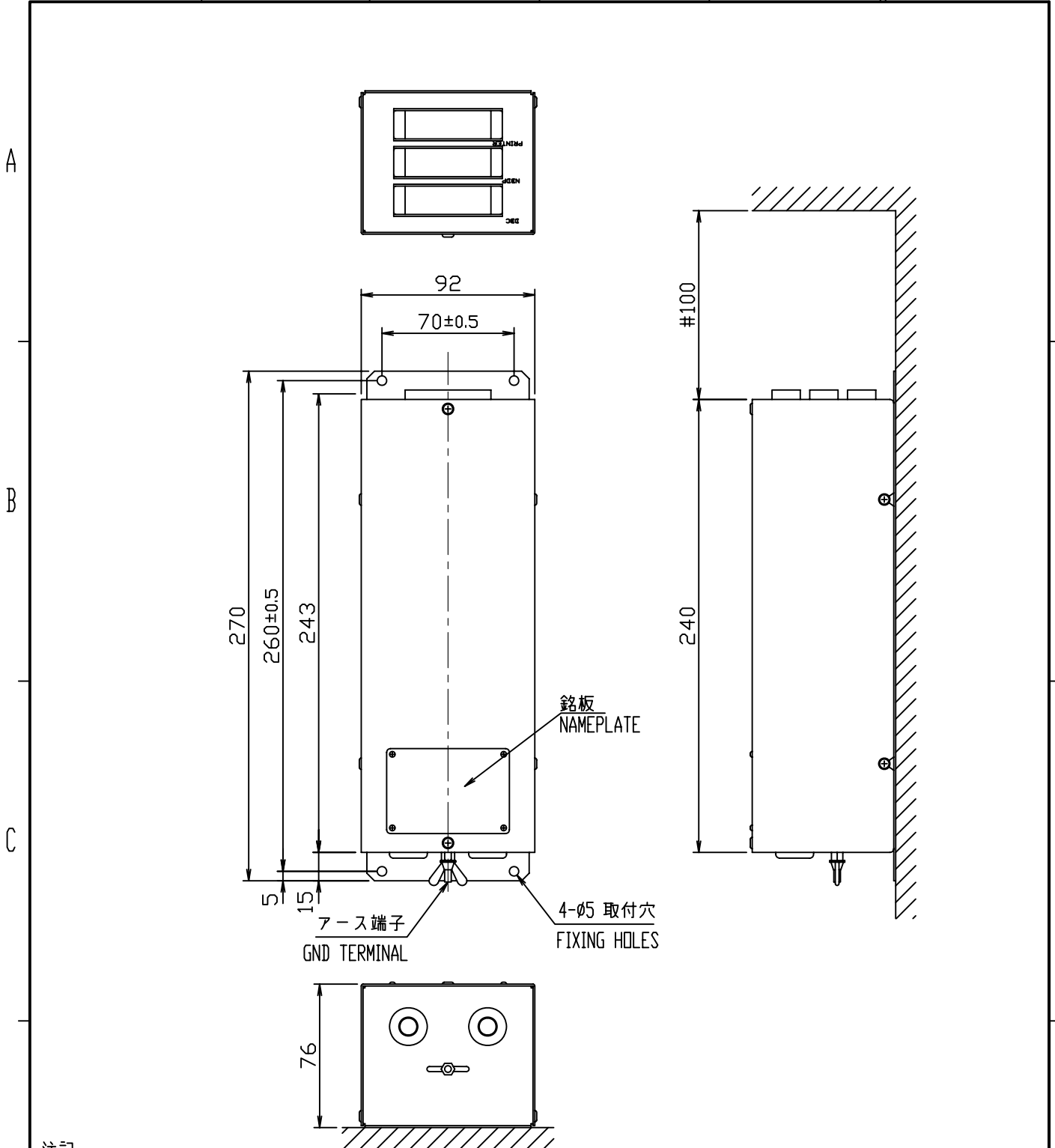

注記

- 1) 指定なき寸法公差は表1による。
- 2) #: 最小サービス空間寸法。

NOTE

- 1. TABLE 1 INDICATES TOLERANCE OF DIMENSIONS WHICH IS NOT SPECIFIED.
- 2. #: MINIMUM SERVICE CLEARANCE.

表1 TABLE 1

寸法区分(mm) DIMENSION	公差(mm) TOLERANCE
0 < L ≤ 50	±1.5
50 < L ≤ 100	±2.5
100 < L ≤ 500	±3

DRAWN Sep. 6 '06 T.YAMASAKI		TITLE IF-8500
CHECKED Sep. 6 '06 T.TAKENO		名称 プリンターインターフェイス
APPROVED Sep. 21 '06 T.Matsuguchi	FM-8500	外寸図
SCALE 1/3	MASS 0.7 ±10% kg	NAME PRINTER INTERFACE
DWG.No. C5603-G05- C	05-073-2100-G1	OUTLINE DRAWING

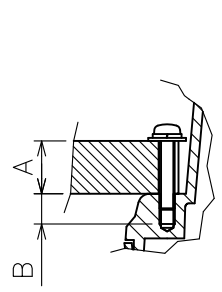
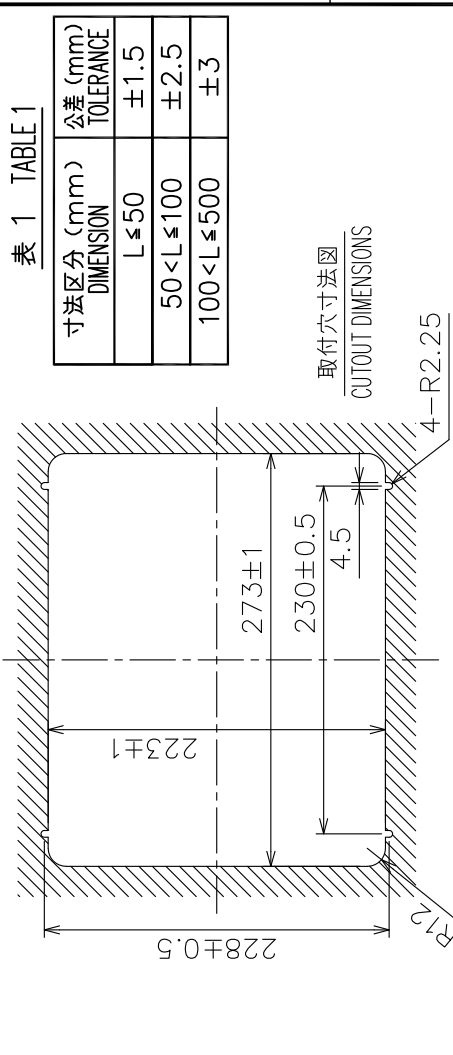

取付部詳細 (尺度: 1/2)  
DETAIL FOR FIXING (SCALE: 1/2)

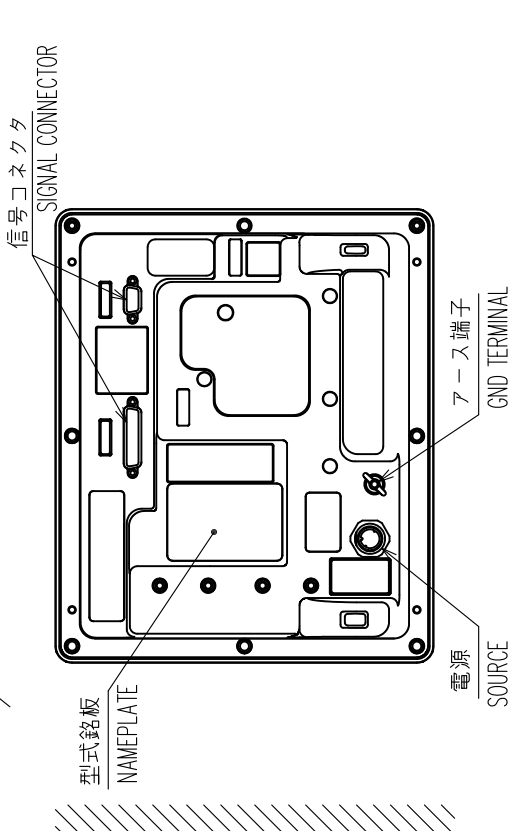
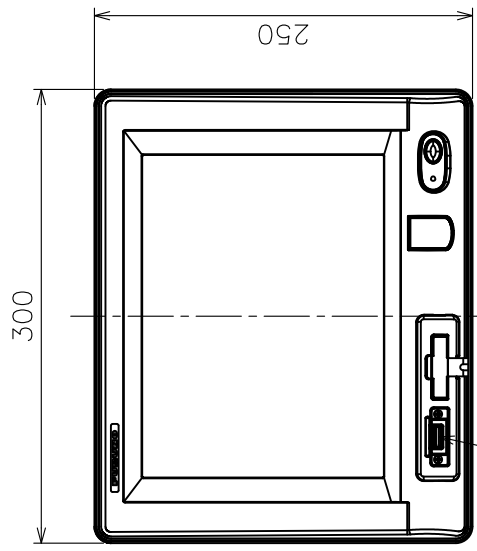
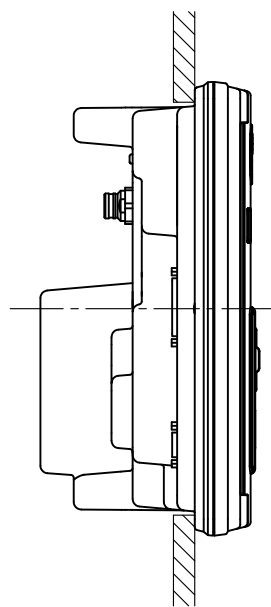
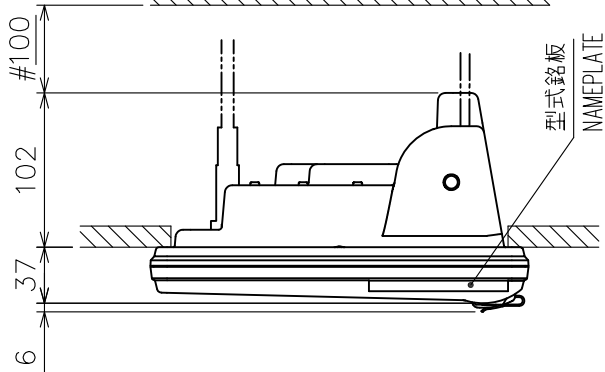

- 注記
- 1) 指定外の寸法公差は表 1 による。
  - 2) # 印寸法は最小サービスマウント寸法とする。
  - 3) 取付用ネジは、セムスネジ B M4×2.0 を使用のこと。  
壁厚さ (A) は  $11 \leq A \leq 14$  とする。  
または、ネジ長さを (A + 7.8) ± 2 とする。  
筐体にはネジ部を 8 mm 以上入れないこと。(B ≤ 8)
- NOTE
1. TABLE 1 INDICATES TOLERANCE OF DIMENSIONS WHICH IS NOT SPECIFIED.
  2. # MINIMUM SERVICE CLEARANCE.
  3. USE SEMS B SCREWS M4×2.0 FOR FIXING THE UNIT.  
THICKNESS (A):  $11 \leq A \leq 14$  OR SCREW LENGTH: (A+7.8) ± 2.  
DO NOT FASTEN SCREWS INTO UNIT MORE THAN 8 mm (B ≤ 8).

DRAWN	20/Jan/2012	T. YAMASAKI	TITLE	IB-585
CHECKED	20/Jan/2012	H. MAKI	名称	ターミナルユニット (埋込装置)
APPROVED	24/Jan/2012	Y. NISHIYAMA	外寸図	
SCALE	1/5	WASS 3.0	NAME	TERMINAL UNIT (FLUSH MOUNT)
DMC No.	C5677-G04-A	REF. No.	05-106-451G-0	OUTLINE DRAWING

表 1 TABLE 1

寸法区分 (mm) DIMENSION	公差 (mm) TOLERANCE
L ≤ 50	±1.5
50 < L ≤ 100	±2.5
100 < L ≤ 500	±3

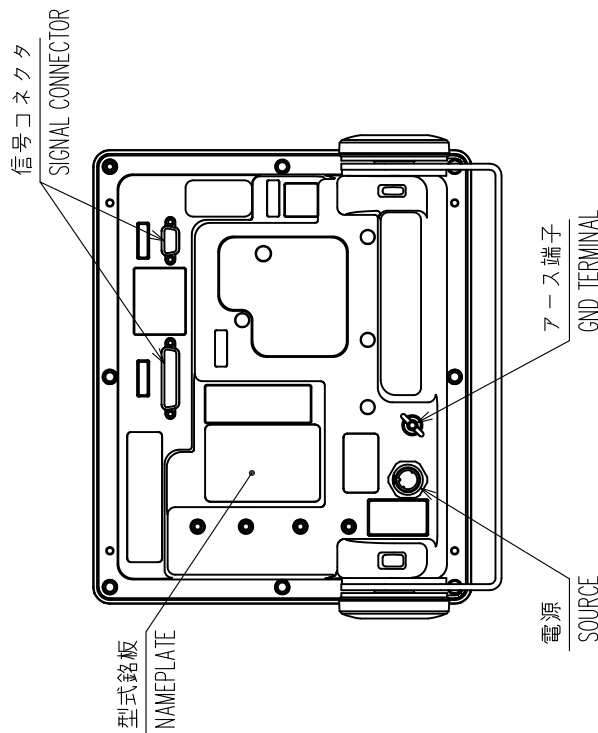
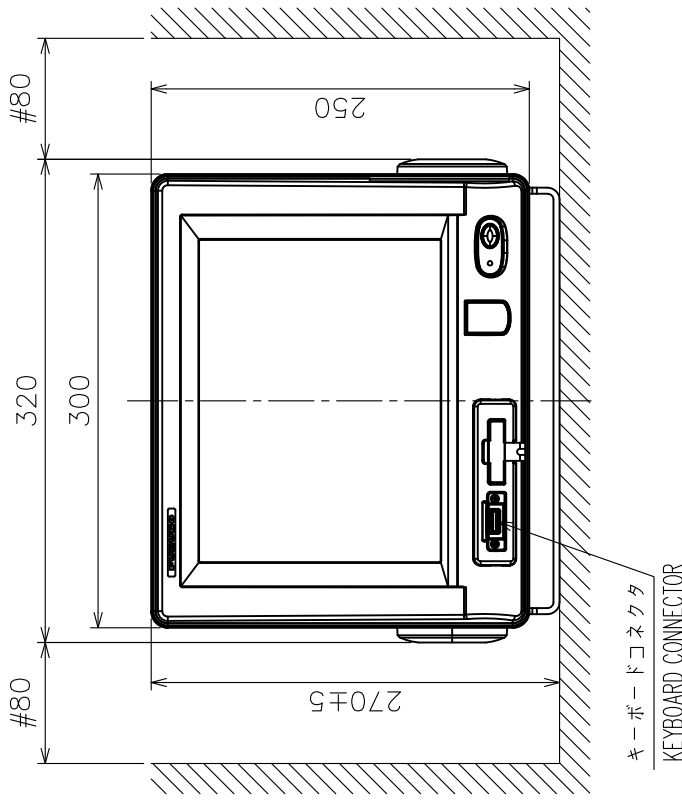
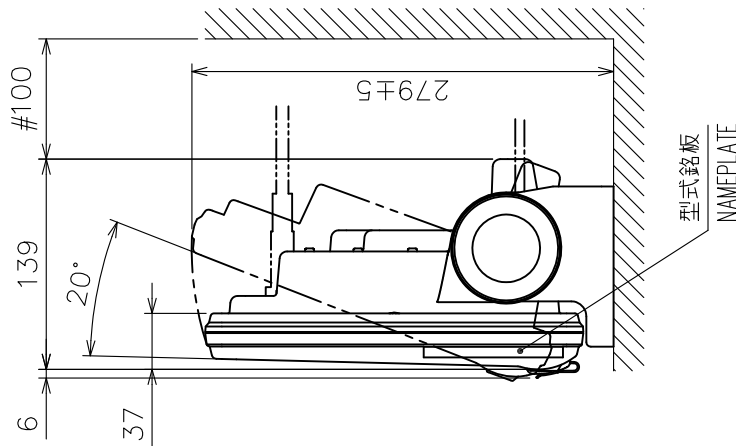
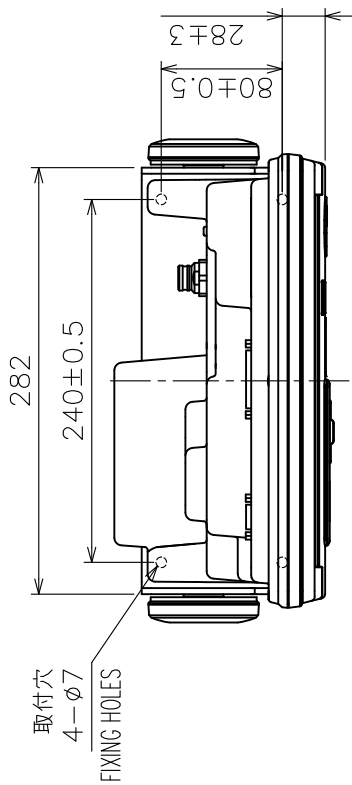

- 注 記
- 1) 指定外の寸法公差は表 1 による。
  - 2) # 印寸法は最小サービスマウントとする。
  - 3) 取付用ネジはトラスタップピンネジ呼び径 5 × 2.0 を使用のこと。

- NOTE
1. TABLE 1 INDICATES TOLERANCE OF DIMENSIONS WHICH IS NOT SPECIFIED.
  2. #: MINIMUM SERVICE CLEARANCE.
  3. USE TAPPING SCREWS φ5x2.0 FOR FIXING THE UNIT.

DRAWN	20/Jan/2012	T. YAMASAKI	TITLE	IB-585
CHECKED	20/Jan/2012	H. MAKI	名称	ターミナルユニット (卓上装備)
APPROVED	24/Jan/2012	Y. NISHIYAMA	外寸図	
SCALE	1/5	質量はアールを含まず。 MASS DOES NOT INCLUDE CABLE.	NAME	TERMINAL UNIT (TABLETOP MOUNT)
DWG.No.	C5677-G05-A	REF.No.	05-106-450G-0	OUTLINE DRAWING

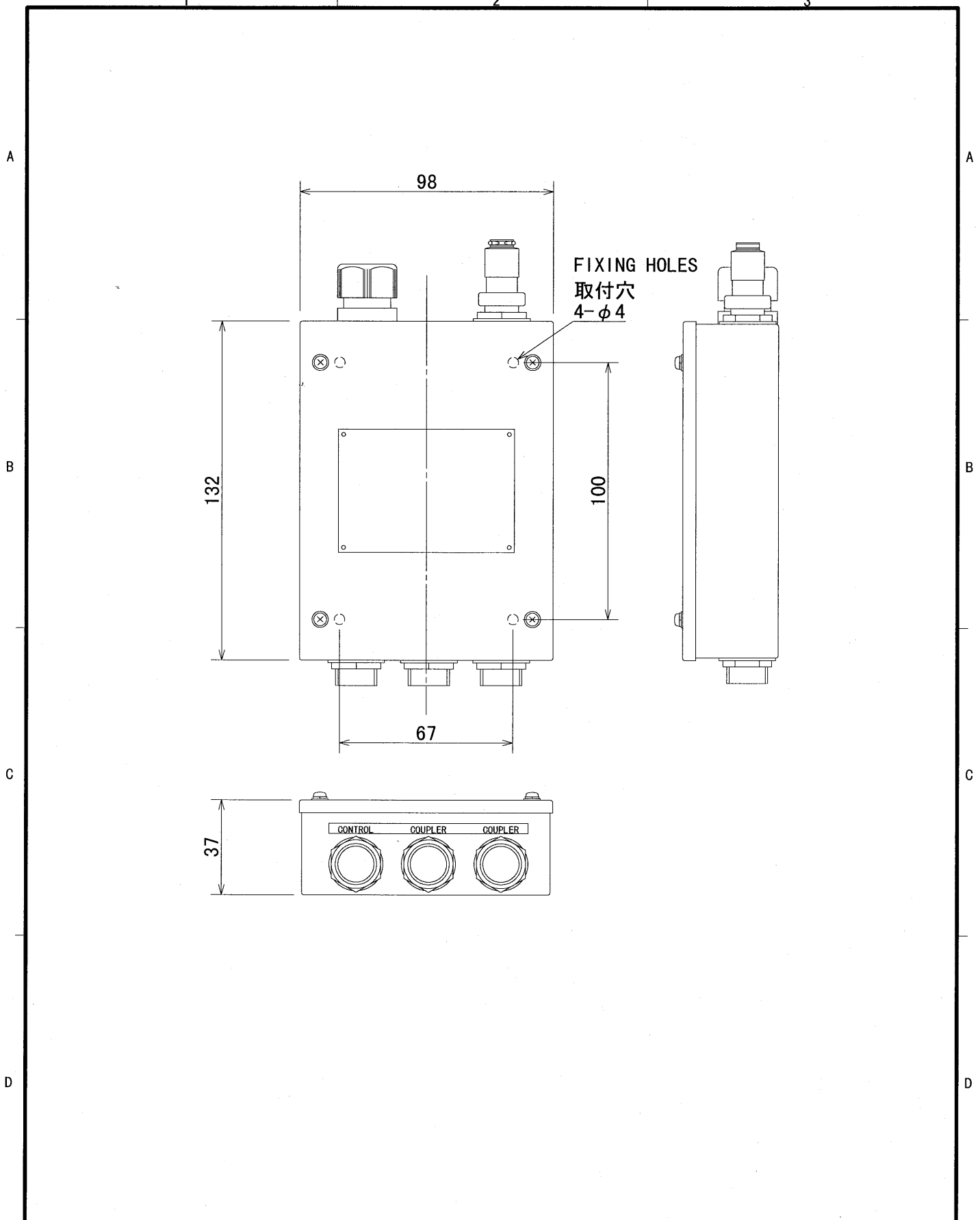

DRAWN Nov. 12 '98 T. YAMASAKI		TITLE BK-300
CHECKED Nov. 12 '98 K. Kusumoki		名称 BKインターフェイス
APPROVED Nov. 12 '98 K. Kusumoki		外寸図
SCALE 1/2	MASS 0.48 kg	NAME BK INTERFACE
DWG. No. C5083-G01- A		OUTLINE DRAWING

A

注意：  
アンテナ線を、給電点より上方に固定する場合は、アンテナ取付台からの距離は1000mm以下とすること。

CAUTION:  
WHEN THE ANTENNA CABLE IS FIXED ABOVE THE FEEDING POINT, THE DISTANCE FROM ANTENNA BASE MUST BE WITHIN 1000 mm.

シンプル  
シャックル  
ワイヤクリップ  
THIMBLE  
SHACKLE  
WIRE CLIP

1000 MAX.

B

アンテナ線 (2m以上)  
ANTENNA WIRE  
(2m OR MORE)

シンプル  
シャックル  
碍子  
ワイヤクリップ  
THIMBLE  
SHACKLE  
INSULATOR  
WIRE CLIP

銅板 (切片)  
COPPER STRAP  
(A SECTION)

ワイヤクリップ  
WIRE CLIP

固定用線  
(支給ケーブルを一部切断)  
FIXING WIRE  
CUT OFF A PART  
FROM CABLE SUPPLIED

C

注記

- 1) インマルサットアンテナまでの距離は5m以上とすること。
- 2) アンテナ基部からチューナーまでケーブルを引くときは、必ず絶縁した状態で、できる限り垂直(水平面となす角が45度以上)にすること。
- 3) ホイップアンテナは少なくとも1m以上他の導体構造物から離して船体上部に設置すること。

NOTE

1. DISTANCE TO THE INMAR-ANTENNA SHOULD BE MORE THAN 5m.
2. THE DOWN LEAD FROM THE BASE OF THE ANTENNA TO THE ANTENNA TUNER SHOULD BE INSULATED AND RUN VERTICALLY (45° OR MORE TOWARDS THE HORIZONTAL PLANE) AS POSSIBLE.
3. WHIP ANTENNAS SHOULD BE LOCATED IN AN ELEVATED POSITION ON THE SHIP AT LEAST 1m AWAY FROM CONDUCTIVE STRUCTURES.

D

銅板  
COPPER STRAP

DRAWN	4/Dec/2015	T.YAMASAKI	TITLE	WHIP ANTENNA
CHECKED	4/Dec/2015	H.MAKI	名称	ホイップアンテナ組立工材 装備例
APPROVED	9/Dec/2015	H.MAKI		装備要領
SCALE	MASS	±10% kg	NAME	WHIP ANTENNA LEAD-IN KIT (FOR REFERENCE)
DWGNo.	C5023-Y01-L			INSTALLATION PROCEDURE



表1 TABLE 1

寸法区分 (mm) DIMENSION	公差 (mm) TOLERANCE
L ≤ 50	±1.5
50 < L ≤ 100	±2.5
100 < L ≤ 500	±3

注 記

- 1) 指定外の寸法公差は表 1 による。
- 2) アンテナおよびアンテナカプラに繋ぐ線については十分な空間を確保すること。
- 3) 取付用ネジはトラスタップピンネジ 呼び径 5 × 20 を使用のこと。

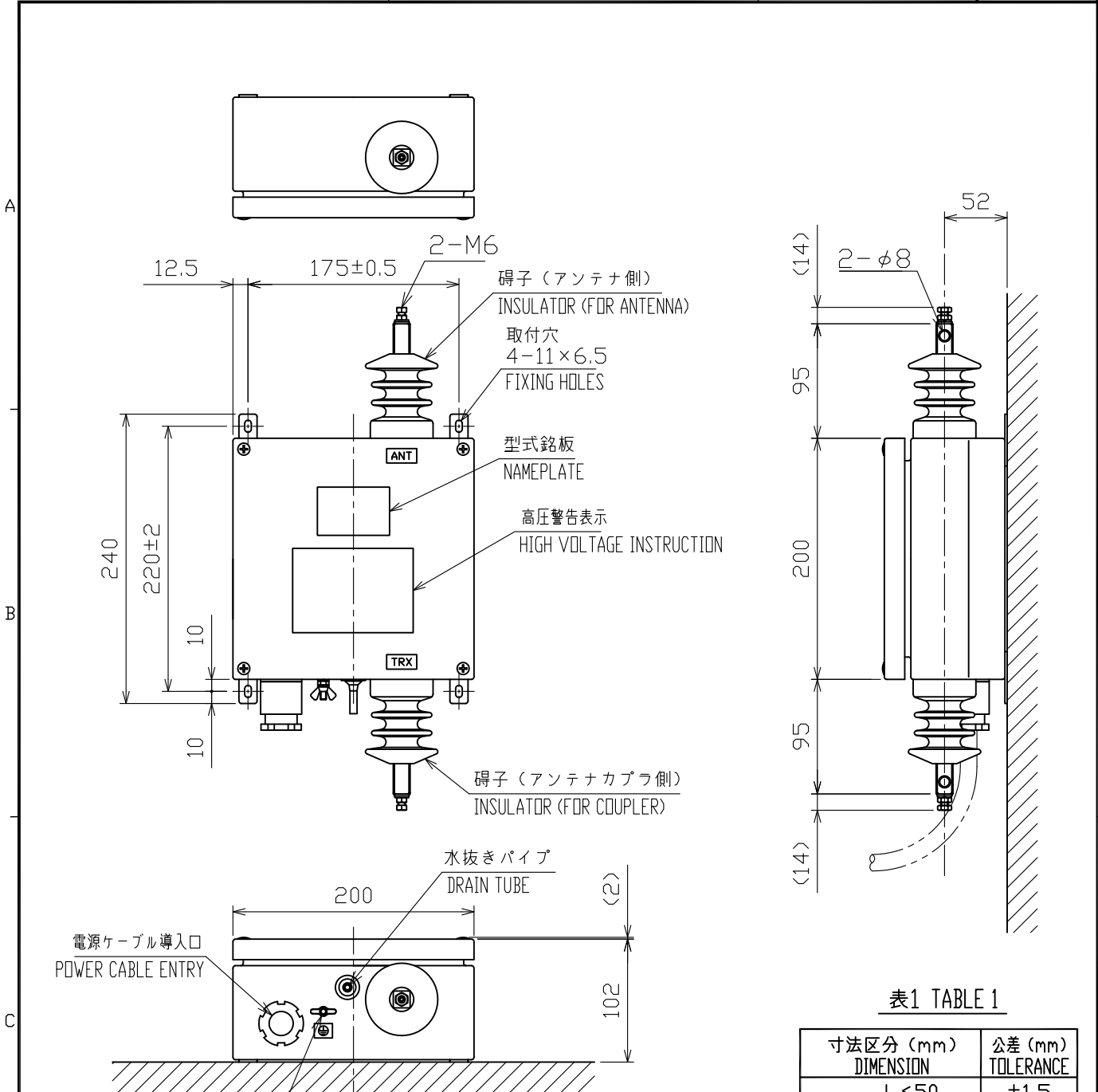
NOTE

1. TABLE 1 INDICATES TOLERANCE OF DIMENSIONS WHICH IS NOT SPECIFIED.
2. KEEP SUFFICIENT CLEARANCE TO CONNECT WIRES TO ANTENNA AND COUPLER.
3. USE TAPPING SCREWS  $\phi 5 \times 20$  FOR FIXING THE UNIT.

DRAWN	1/Aug/2109 T.YAMASAKI	TITLE	AS-102
CHECKED	1/Aug/2109 H.MAKI	名称	自動アンテナ切換器
APPROVED	1/Aug/2019 H.MAKI	FS-1570/2570/5070	外寸図
SCALE	1/5	MASS	3.2 ±10% kg
DWG. No.	C5656-G04-B	REF. No.	05-094-400G-2
		NAME	ANTENNA SWITCH
			OUTLINE DRAWING

A

B

C

D

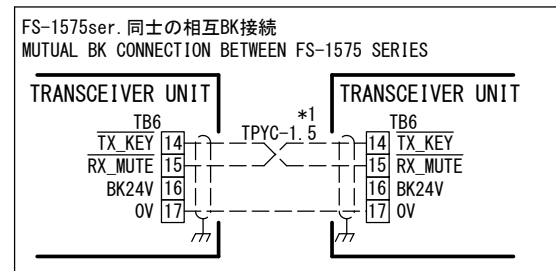
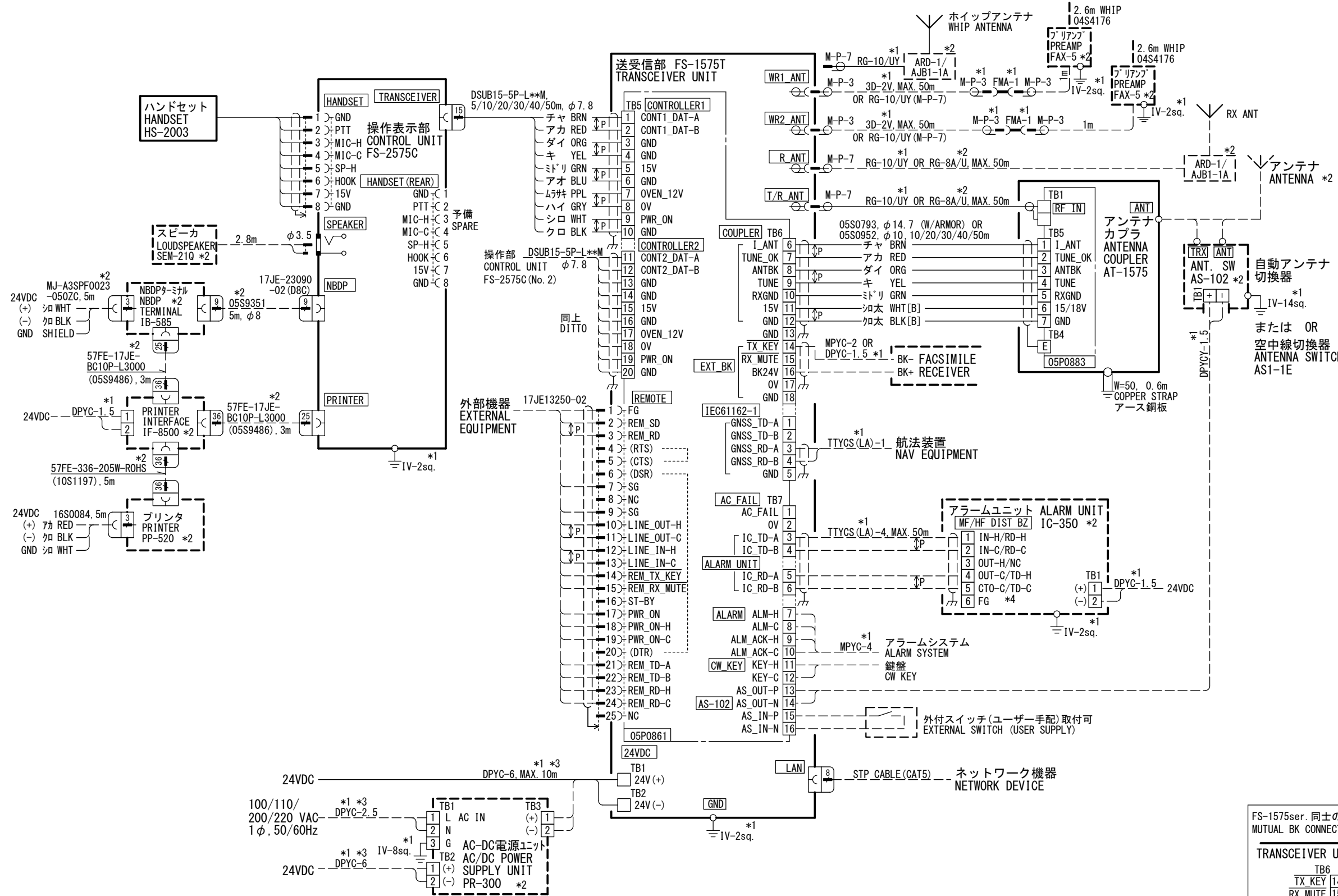

注記  
 \* 1) 造船所手配。  
 \* 2) オプション。  
 \* 3) 長さに応じて芯線太さを変更する。  
 \* 4) 内部スイッチ設定が必要。

NOTE  
 \*1: SHIPYARD SUPPLY.  
 \*2: OPTION.  
 \*3: CHANGE WIRE THICKNESS ACCORDING AS CABLE LENGTH.  
 \*4: INTERNAL SWITCH SETTING REDUIRED.

DRAWN 1/Jun/2016 T. YAMASAKI	TITLE FS-1575
CHECKED 1/Jun/2016 H. MAKI	名称 SSB送受信機
APPROVED 3/Jun/2016 H.MAKI	相互結線図
SCALE MASS	NAME SSB RADIOTELEPHONE
DWG. No. C5676-C01- G	REF. No. INTERCONNECTION DIAGRAM

A

B

C

D

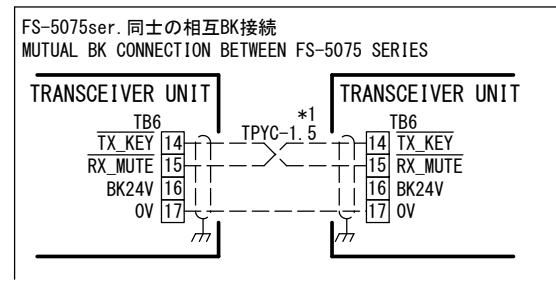
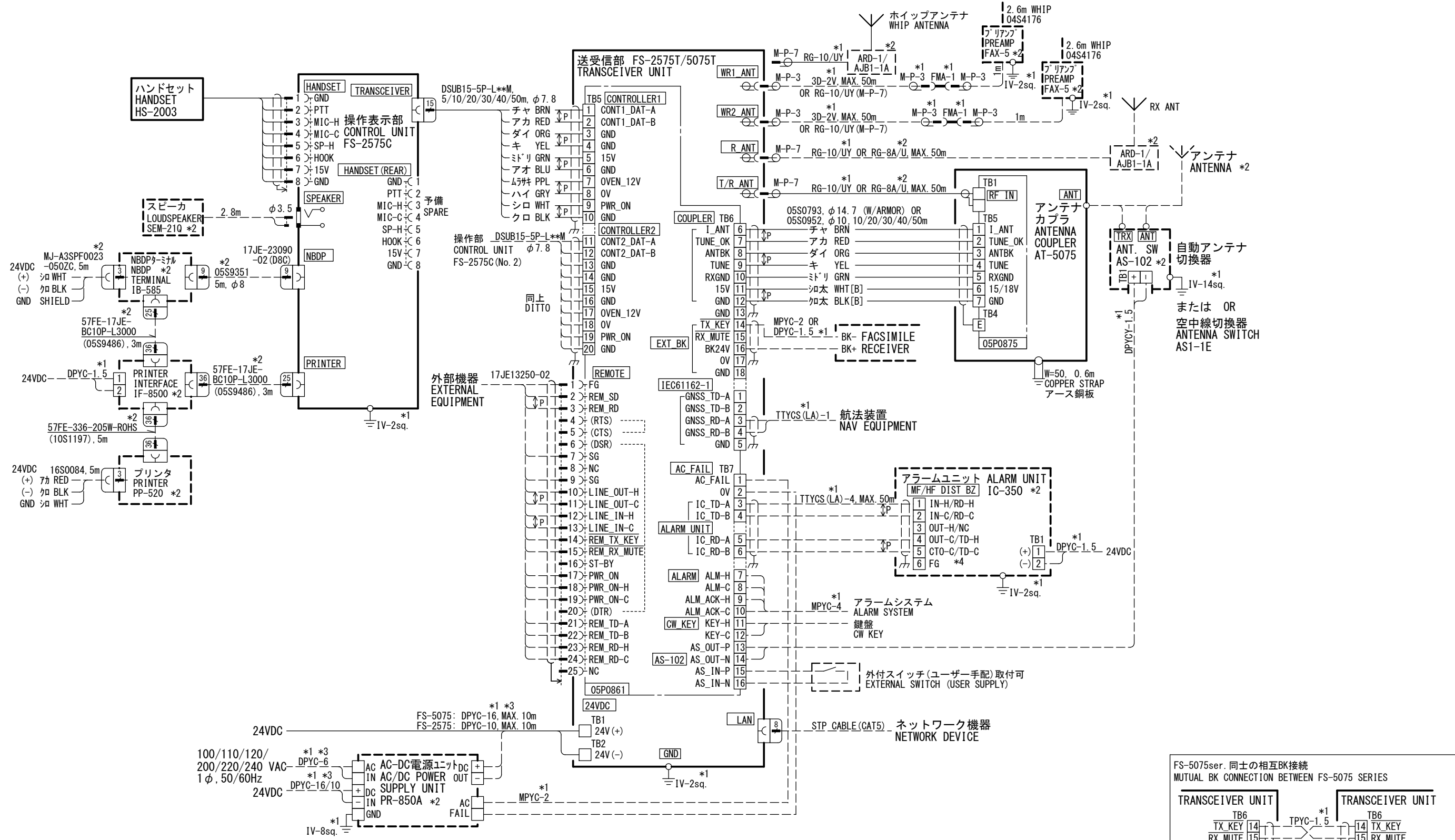

注記  
\* 1) 造船所手配。  
\* 2) オプション。  
\* 3) 長さに応じて芯線太さを変更する。  
\* 4) 内部スイッチ設定が必要。

NOTE  
\*1: SHIPYARD SUPPLY.  
\*2: OPTION.  
\*3: CHANGE WIRE THICKNESS ACCORDING AS CABLE LENGTH.  
\*4: INTERNAL SWITCH SETTING REDUIRED.

DRAWN 1/Jun/2016 T. YAMASAKI	TITLE FS-2575/5075
CHECKED 1/Jun/2016 H. MAKI	名称 SSB送受信機
APPROVED 3/Jun/2016 H.MAKI	相互結線図
SCALE MASS	NAME SSB RADIOTELEPHONE
DWG. No. C5678-C01-K	REF. No. INTERCONNECTION DIAGRAM



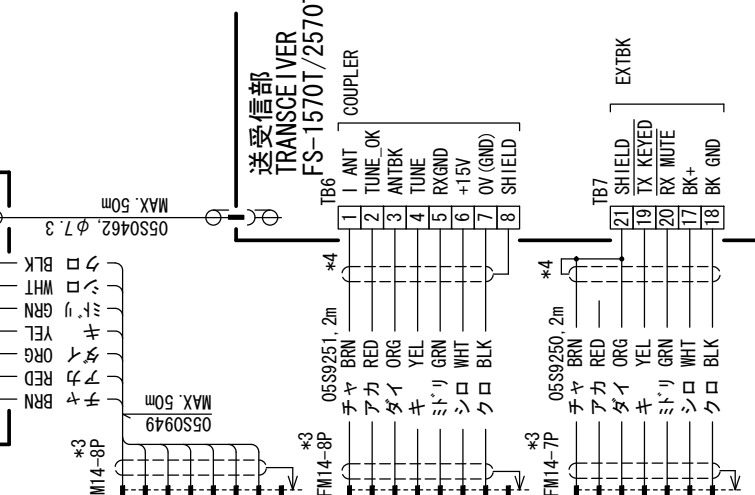
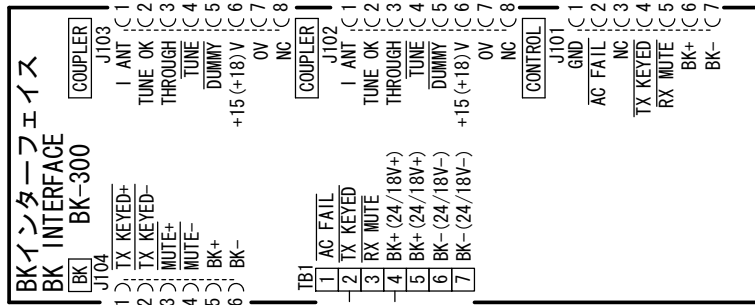
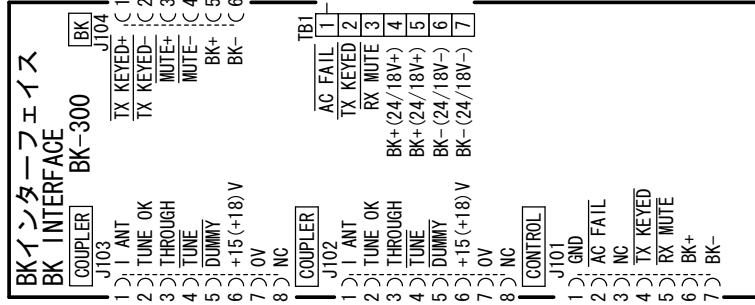
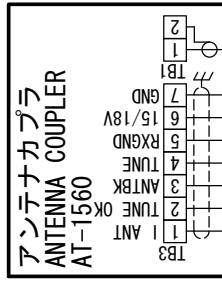
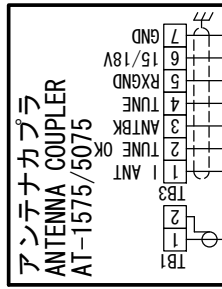

**注記**

- \* 1) 造船所手配
- \* 2) オプション。
- \* 3) コネクタは工場にて取付済み。
- \* 4) プラグを切断して芯線をコネクタピンに接続する。

**NOTE**

- \*1: SHIPYARD SUPPLY.
- \*2: OPTION
- \*3: CONNECTOR PLUGS FITTED AT FACTORY.
- \*4: CONNECT WIRES TO PIN CONNECTOR AFTER PLUG REMOVED.

DRAWN	29/AUG/2012	I. YAMASAKI	TITLE	BK-300 (FS-5075ser. + FS-1570ser.)
CHECKED	29/AUG/2012	H. MAKI	名称	BK インターフェイス
APPROVED	29/AUG/2012	Y. NISHIYAMA	相互結線図	
SCALE	MASS	kg	NAME	BK INTERFACE
DWG No.	C5083-C03-B		INTERCONNECTION DIAGRAM	