

**FURUNO**

*Installation Manual*  
**GPS/WAAS COLOR CHART PLOTTER**  
*Model GP-3700*

---

**SAFETY INSTRUCTIONS** ..... i  
**SYSTEM CONFIGURATION** ..... ii  
**EQUIPMENT LISTS**..... iii

**1. MOUNTING**..... 1  
1.1 Display Unit..... 1  
1.2 Antenna Unit ..... 5  
1.3 Trackball Control Unit (Option) ..... 5  
1.4 External Monitor (Locally Supplied) ..... 8

**2. WIRING**..... 10  
2.1 How to Connect the Unit ..... 10  
2.2 DIP Switch Settings ..... 19  
2.3 Input/Output Data..... 19

**3. SETTING UP THE EQUIPMENT** ..... 25  
3.1 Language Setting ..... 25  
3.2 NMEA Equipment Setting ..... 26  
3.3 Own Ship Information Setting ..... 28  
3.4 Event Switch Setting ..... 30  
3.5 Input/Output Port Setting ..... 31  
3.6 DGPS Setting..... 36  
3.7 How to Control Charts..... 38

**APPENDIX 1 JIS CABLE GUIDE** ..... AP-1

**PACKING LISTS** ..... A-1  
**OUTLINE DRAWINGS** ..... D-1  
**INTERCONNECTION DIAGRAM** ..... S-1



[www.furuno.com](http://www.furuno.com)

All brand and product names are trademarks, registered trademarks or service marks of their respective holders.



# SAFETY INSTRUCTIONS

The installer must read the appropriate safety instructions before attempting to install the equipment.



## WARNING

Indicates a potentially hazardous situation which, if not avoided, could result in death or serious injury.



## CAUTION

Indicates a potentially hazardous situation which, if not avoided, may result in minor or moderate injury.

(Examples of symbols)



Warning, Caution



Prohibitive Action



Mandatory Action



## WARNING



**Do not disassemble or modify the equipment.**

Fire, electrical shock or serious injury can occur.



**Turn off the power at the switchboard before beginning the installation.**

Fire or electrical shock can result if the power is left on.



## CAUTION



**Ground the equipment to prevent electrical shock and mutual interference.**



**Use only the specified power and signal cable.**

Fire or damage to the equipment can result if a different cable is used.



**Use the proper fuse.**

Use of an incorrect fuse may damage the equipment.



**Observe the following compass safe distances to prevent interference to a magnetic compass:**

	Standard compass	Steering compass
Display Unit GP-3700	1.15 m	0.75 m
Trackball Control Unit RCU-030	0.50 m	0.30 m
Antenna Unit GPA-020S	0.30 m	0.30 m
Antenna Unit GPA-021S	0.30 m	0.30 m
Antenna Unit GPA-C01S	0.40 m	0.30 m

# SYSTEM CONFIGURATION

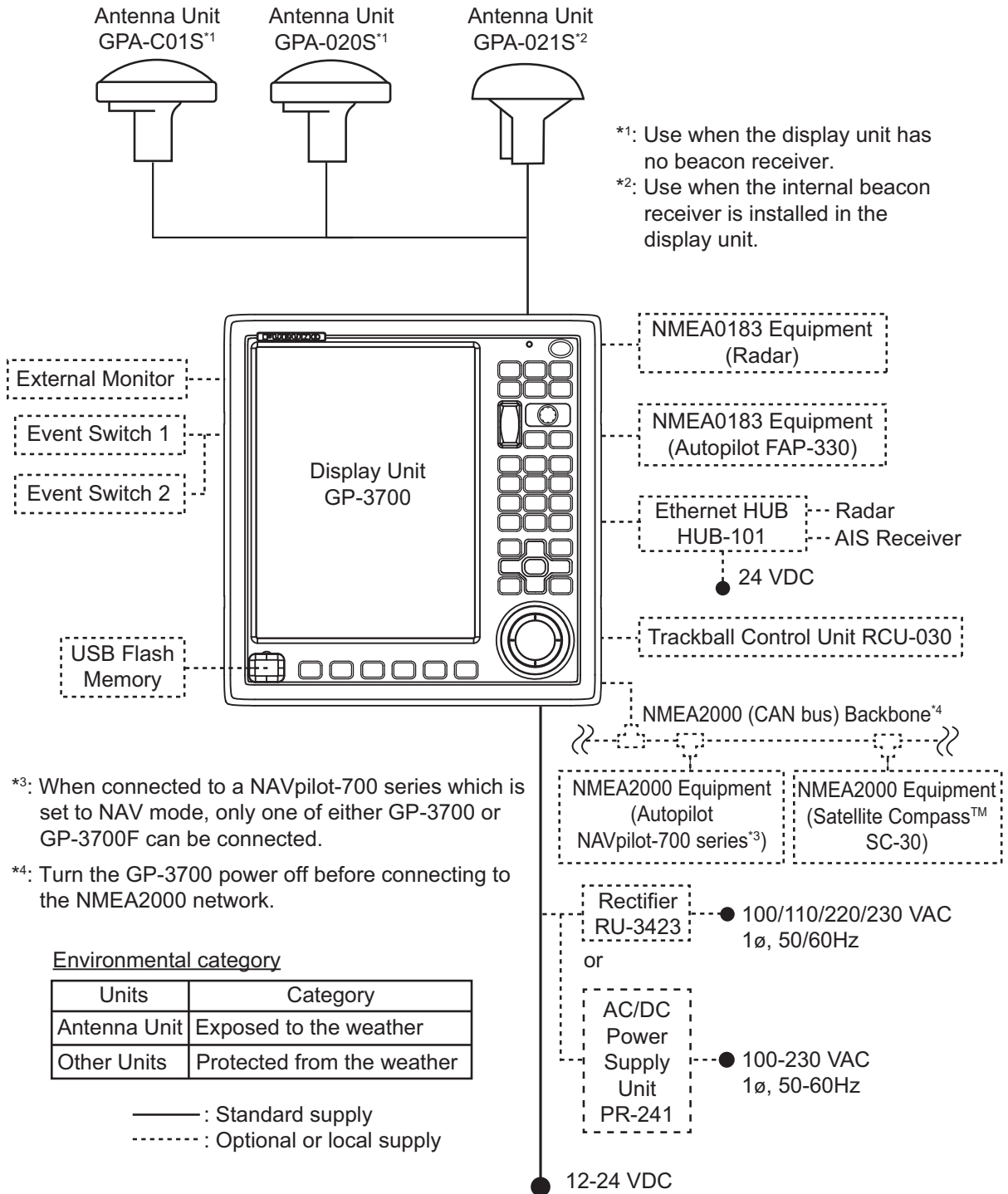

# EQUIPMENT LISTS

## Standard Supply

Name	Type	Code No.	Qty	Remarks
Display Unit	GP-3700	-	1	With hard cover
Antenna Unit	GPA-C01S	-	0 or 1	For GPS. Use when the display unit has no beacon receiver.
	GPA-020S	-		
	GPA-021S	-		For DGPS. Use when the internal beacon receiver is installed to the display unit.
Installation Materials	CP14-08200	000-029-328	1	With antenna cable assy. and mast mount kit
		000-035-346		
	CP14-08210	000-029-329		Without mast mount kit
		000-035-347		
	CP14-08220	000-029-330		Without antenna cable assy. and mast mount kit
		000-035-348		
Accessories	FP14-03400	000-029-327	1	
		000-035-349		
Spare Parts	SP14-03601	001-246-900	1	
		001-303-400		

## Optional Supply

Name	Type	Code No.	Remarks
Trackball Control Unit	RCU-030	-	
Antenna Unit	GPA-C01S	-	For GPS
	GPA-020S	-	
	GPA-021S	-	For DGPS
Rectifier	RU-3423	-	
AC/DC Power Supply Unit	PR-241	-	
Ferrite Core	OP86-11	001-594-450	For PR-241
Beacon Receiver Set	OP14-80	000-029-392	With modification instructions
Monitor Option	OP14-82	000-029-467	For connecting external monitor
Flush Mount	OP14-83	000-029-394	For display unit
FM Fixture Assembly	OP24-38	001-263-190	For trackball control unit
Right Angle Mounting Base	NO.13-QA330	001-111-910-10	For antenna unit
L-Angle Mounting Base	NO.13-QA310	001-111-900-10	
Handrail Mounting Base	NO.13-RC5160	001-111-920-10	
Mast Mounting Kit	CP20-01111	004-365-780	

<b>Name</b>	<b>Type</b>	<b>Code No.</b>	<b>Remarks</b>
Antenna Cable Assembly	CP20-01700	004-372-110	CP20-01701 + 30 m cable For extending antenna cable
	CP20-01720	001-207-980	CP20-01701 + 40 m cable For extending antenna cable
	CP20-01710	004-372-120	CP20-01701 + 50 m cable For extending antenna cable
	CP20-02700	004-381-160	CP20-02701 + 30 m cable For extending antenna cable
	CP20-02720	001-207-990	CP20-02701 + 40 m cable For extending antenna cable
Antenna Cable Assembly	CP20-02710	004-381-170	CP20-02701 + 50 m cable For extending antenna cable
Cable Assembly	TNC-PS/PS-3D-L15M-R	001-173-110-10	Antenna cable, 15 m
	M12-05BM+05BF-010	001-105-750-10	For NMEA2000 connection, w/connectors (micro), 1 m
	M12-05BM+05BF-020	001-105-760-10	For NMEA2000 connection, w/connectors (micro), 2 m
	M12-05BM+05BF-060	001-105-770-10	For NMEA2000 connection, w/connectors (micro), 6 m
	M12-05BFFM-010	001-105-780-10	For NMEA2000 connection, w/connector (micro), 1 m
	M12-05BFFM-020	001-105-790-10	For NMEA2000 connection, w/connector (micro), 2 m
	M12-05BFFM-060	001-105-800-10	For NMEA2000 connection, w/connectors (micro), 6 m
	CB-05PM+05BF-010	000-167-968-11	For NMEA2000 connection, w/connectors (mini), 1 m
	CB-05PM+05BF-020	000-167-969-11	For NMEA2000 connection, w/connectors (mini), 2 m
	CB-05PM+05BF-060	000-167-970-11	For NMEA2000 connection, w/connectors (mini), 6 m
	CB-05BFFM-010	000-167-971-11	For NMEA2000 connection, w/connector (mini), 1 m
	CB-05BFFM-020	000-167-972-11	For NMEA2000 connection, w/connector (mini), 2 m
	CB-05BFFM-060	000-167-973-11	For NMEA2000 connection, w/connector (mini), 6 m
	3COX-2P-6C 5M	001-077-230-10	For external monitor, 5 m
	3COX-2P-6C 10M	001-077-220-10	For external monitor, 10 m

## EQUIPMENT LISTS

Name	Type	Code No.	Remarks
Signal Cable Assembly	MJ-A6SPF0012-050C	000-154-053-10	For NMEA0183 connection, w/connectors, 5 m
	MJ-A6SPF0012-100C	000-154-037-10	For NMEA0183 connection, w/connectors, 10 m
	MJ-A6SPF0012-150C	000-161-513-10	For NMEA0183 connection, w/connectors, 15 m
	MJ-A6SPF0003-020C	000-154-029-10	For NMEA0183 connection, w/connector, 2 m
	MJ-A6SPF0003-050C	000-154-054-10	For NMEA0183 connection, w/connector, 5 m
	MJ-A6SPF0003-100C	000-168-924-10	For NMEA0183 connection, w/connector, 10 m
	MJ-A6SPF0003-150C	000-159-643-10	For NMEA0183 connection, w/connector, 15 m
LAN Cable Assembly	MOD-WPAS0001-030+	000-164-609-10	LAN cable with waterproofing modular plug, 3 m
	MOD-Z072-020+	001-167-880-10	2 m
	MOD-Z072-050+	001-167-890-10	5 m
	MOD-Z072-100+	001-167-900-10	10 m
Installation Materials	CP03-28920	000-082-660	LAN cable with armor, 30 m
	CP03-28930	000-084-368	LAN cable with armor, 50 m
Joint Box	TL-CAT-012	000-167-140-10	For LAN cable extension

# 1. MOUNTING

---

## NOTICE

**Do not apply paint, anti-corrosive sealant or contact spray to coating or plastic parts of the equipment.**

Those items contain organic solvents that can damage coating and plastic parts, especially plastic connectors.

## 1.1 Display Unit

The display unit can be installed on a desktop, overhead or flush mounted in a console (option kit is required).

### **Mounting consideration**

Select a mounting location, keeping in mind the following points:

- Select a location where the unit can easily be operated.
- Keep the unit out of direct sunlight.  
The LCD can blackout if the unit is exposed to direct sunlight for a long time.
- Locate the unit way from places subject to water splash and rain.
- The temperature at the mounting location shall be between -15°C and +55°C.
- Locate the unit away from exhaust pipes and vents.
- The mounting location should be well ventilated.
- Select a location where shock and vibration are minimal.
- Referring to the outline drawings at the back of this manual, allow sufficient space for maintenance and service.
- Select a mounting location considering the length of the cables to be connected to the unit.
- Do not place items which should not get wet near the display unit.  
There is the drain hole on the bottom of this unit. If water enters the unit from the clearance around the trackball, water is drained from the drain hole.
- A magnetic compass will be affected if the unit is placed too close to the magnetic compass. Observe the compass safe distances at the front of this manual to prevent interference to a magnetic compass.

## 1. MOUNTING

### 1.1.1 Desktop or overhead mounting

1. Unfasten the knob bolts and remove the display unit from the bracket.

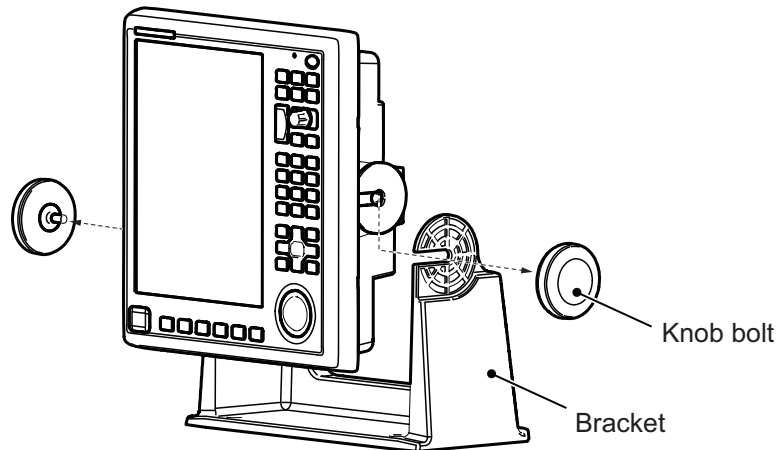

2. Secure the bracket to the mounting location with four self-tapping screws ( $\phi 5 \times 20$ , supplied).

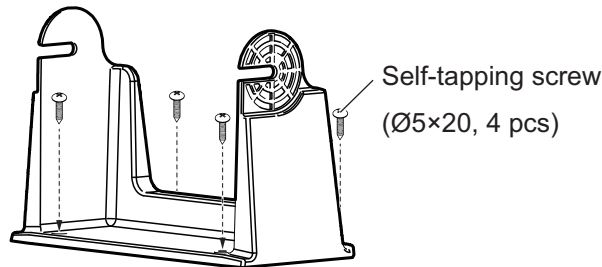

3. Connect all necessary cables, referring section 2.1.  
**Note:** Place the display unit face-down on a soft, clean surface to prevent damage to the LCD.
4. Set the display unit in the bracket, then fasten the knob bolts.

### 1.1.2 Flush mounting in a console (option)

Use the optional flush mount kit OP14-83, for flush mounting the display unit.

*Type: OP14-83. Code No.: 000-029-394*

Name	Type	Code No.	Qty
F Mount Sponge TOP	14-083-1091-0	100-401-120-10	1
F Mount Sponge SIDE	14-083-1092-0	100-401-130-10	2
F Mount Sponge BOT	14-083-1093-1	100-401-141-10	1
Flush Mount Fixture	OP03-228-1	001-258-040	1
Hexagonal Head Slot Bolt	M8×15	000-162-916-10	2
Flat Washer	M8	000-167-464-10	2
Front Fixing Plate	14-083-1094-0	100-401-150-10	1

**Note:** Ensure the mounting location is flat, with no indents or protrusions, to allow a secure fit.

1. Prepare a mounting hole in the installation location, using the supplied mounting template.
2. Unfasten the two knob bolts to remove the display unit from the bracket.



- Attach the F mount sponge TOP, F mount sponge SIDE and F mount sponge BOT, referring to the following figure.

**Note 1:** Place the display unit face-down on a soft, clean surface to prevent damage to the LCD.

**Note 2:** Take care not to cover the screw holes with the F mount sponges.

**Note 3:** Ensure there are no gaps between the sponges at their joining points.

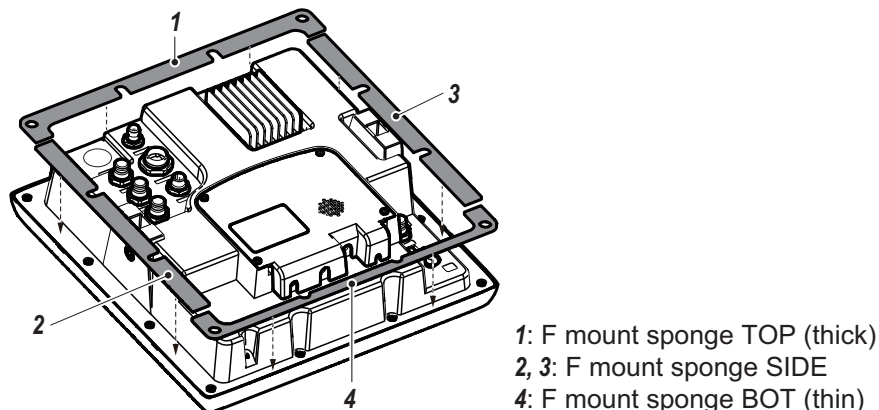

- Set the front fixing plate to the display unit from the rear side.

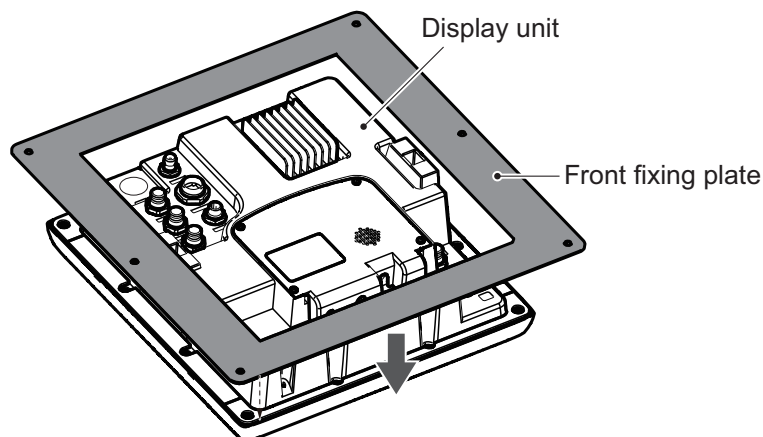

- Connect all necessary cables, referring section 2.1.
- Loosen the wing nuts and wing bolts of the flush mount fixture to move the protector to the fixture.

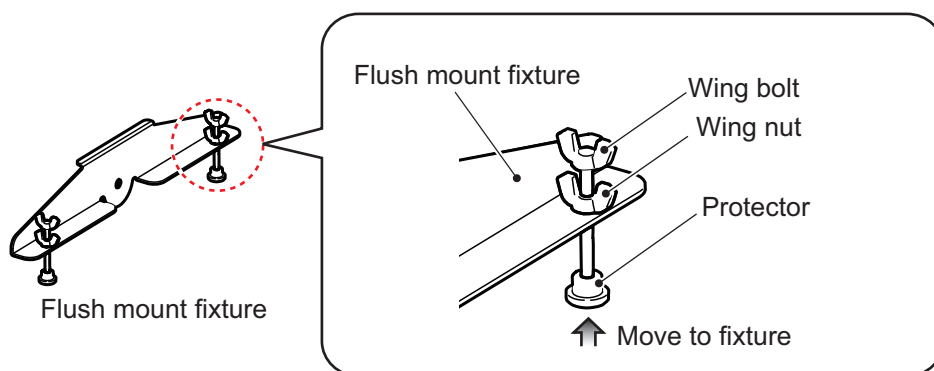

## 1. MOUNTING

- Attach the two flush mount fixtures to the unit, using flat washers (M8) and hexagonal head slot bolts (M8×15).  
Use the knob bolt holes to fasten hexagonal head slot bolts.

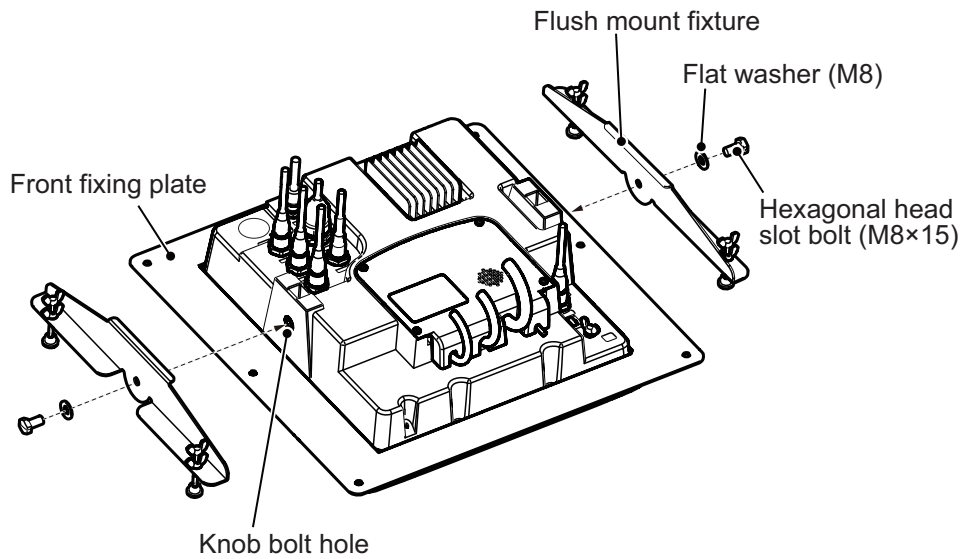

- Tighten the four wing bolts on the flush mount fixture until the protector contacts the front fixing plate and the flush mounting fixture is firmly secured.
- Tighten four wing nuts on the flush mount fixture.

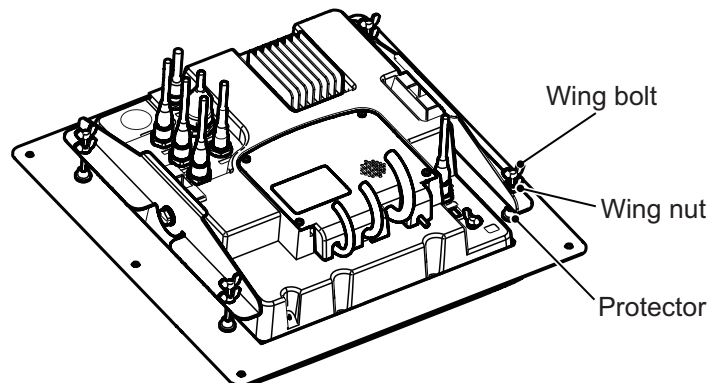

- Set the display unit to the mounting hole.  
**Note:** Take care that cables connected to the unit are not pinched between the unit and console.
- Fasten the display unit with six self-tapping screws ( $\phi 5 \times 20$ , supplied).

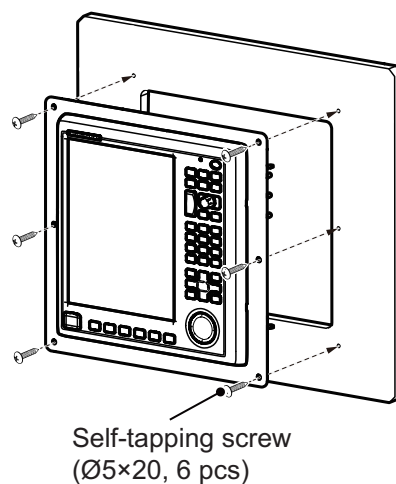

## 1.2 Antenna Unit

### 1.2.1 Mounting

Install the antenna unit referring to the "INSTALLATION PROCEDURE" at end of manual.

#### Mounting considerations

Select a mounting location, keeping in mind the following points:

- Select a location out of the radar and inmarsat beams. Those beams will obstruct or prevent reception of the GPS satellite signal.
- The location should be well away from a VHF/UHF antenna. Harmonic waves from a VHF/UHF antenna interfere with the GPS receiver.
- There should be no interfering objects within the line-of-sight to the satellites. An object within line-of-sight to satellites, for example, a mast, may block reception or prolong acquisition time.
- Mount the antenna unit as high as possible to keep it free from interfering objects and water spray. Freezing water can interrupt reception of the GPS satellite signal.
- If the antenna cable is to be passed through a hole in a bulkhead which is too small to pass the connector, disassemble the connector with radio pincers and a monkey wrench. After passing the cable through the hole, assemble the connector as below.

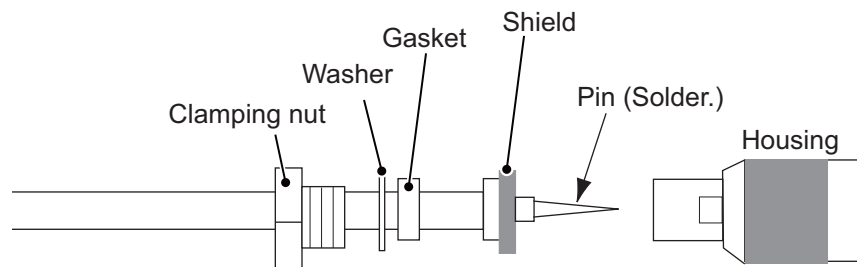

## 1.3 Trackball Control Unit (Option)

The trackball control unit can be mounted on a desktop or flush mounted in a console (option).

#### Mounting considerations

When selecting a mounting location for the trackball control unit, keep in mind the following points.

- Select a location where the controls can be easily operated.
- Locate the unit away from heat sources.
- Locate the unit away from places subject to water splash and rain.
- Referring to the outline drawings at the back of this manual, allow room for maintenance and service.
- Select a mounting location considering the length of the cable.
- Do not place items which should not get wet near the display unit.  
There is the drain hole on the bottom of this unit. If water enters the unit from the clearance around the trackball, water is drained from the drain hole.

## 1. MOUNTING

- A magnetic compass will be affected if the unit is placed too close to the magnetic compass. Observe the compass safe distances at the front of this manual to prevent interference to a magnetic compass.

### 1.3.1 How to install the unit on a desktop

1. Secure the metal mounting plate to the bottom of the unit using two washer head screws (M4×10), both supplied with the trackball control unit, referring to the following figure.

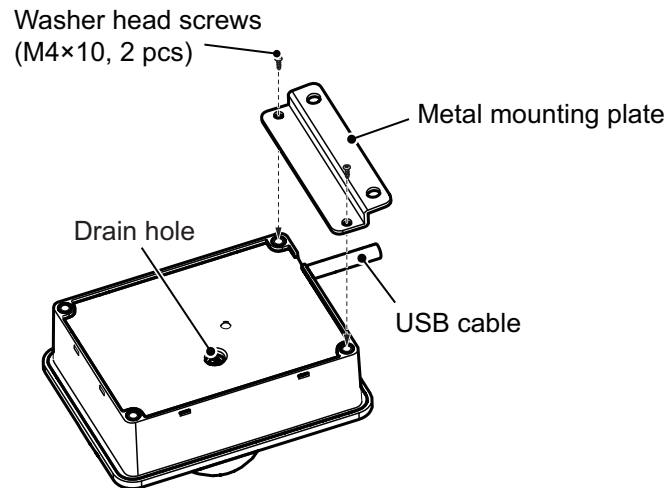

2. Secure the unit to the mounting location using two self-tapping screws (Ø5×20, supplied).

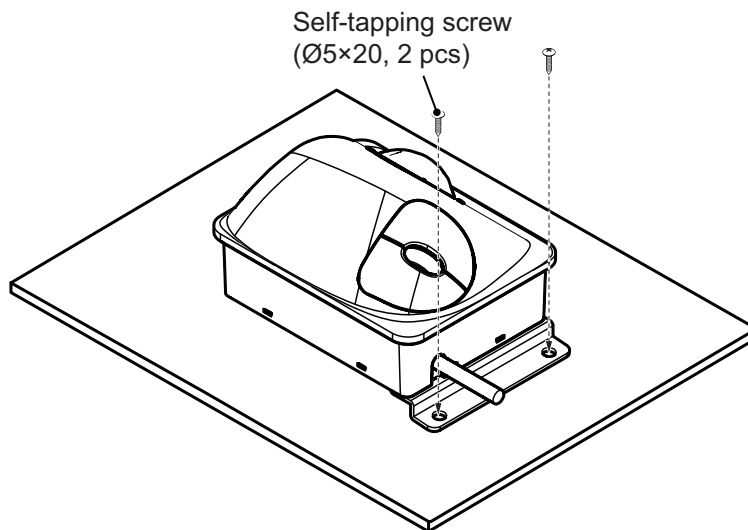

### 1.3.2 How to install the unit in a console (option)

Use the optional FM (flush mount) fixture assembly OP24-38, for flush mounting the trackball control unit.

*Type: OP24-38, Code No.: 001-263-190*

Name	Type	Code No.	Qty
FM Fixture Assembly	OP24-38-1	001-263-200	2
Washer Head Screw	M4×10	000-163-836-10	4

**Note:** The flush mount location must have a thickness of at least 10 mm, with a maximum thickness of 20 mm.

1. Prepare a mounting hole in the installation location, referring the outline drawing at the back of the manual.
2. Set the unit to the mounting hole.

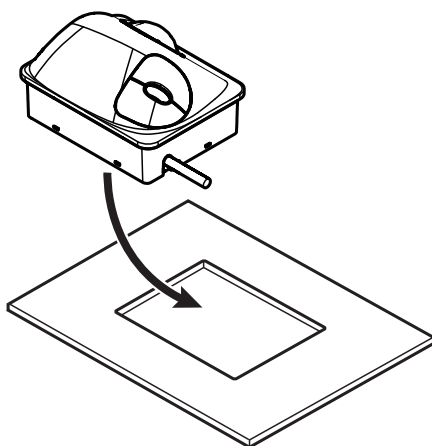

3. Attach the two FM fixture assemblies to the unit's under side using four washer head screws (M4×10), both included in the kit.

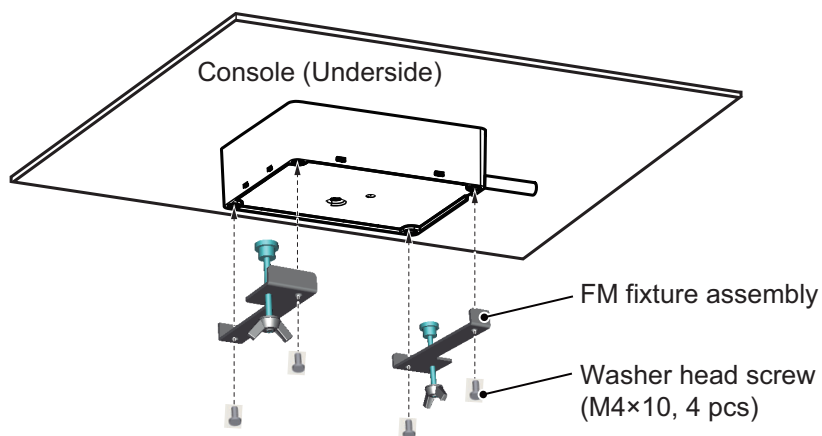

4. Fasten the two wing bolts until the protector contacts the console (underside).

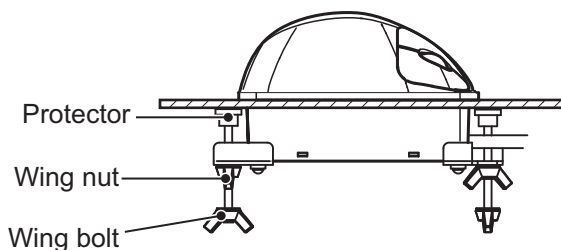

5. Tighten the wing nuts until the unit is firmly secured.

## 1.4 External Monitor (Locally Supplied)

Prepare the monitor option (type: OP14-82, option) to connect an external monitor. You can connect a MU-150HD or a commercial monitor as an external monitor. The external monitor must have the following specifications.

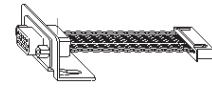

Monitor option

- Video signal: Analog VGA
- Resolution: SVGA (800×600)

**Note 1:** Use an external monitor whose aspect ratio is “4:3”. If other monitors are used, the screen on the display is zoomed in or zoomed out.

**Note 2:** When the MU-150HD is used, the screen rotates 90° to the left as shown in the following figure.

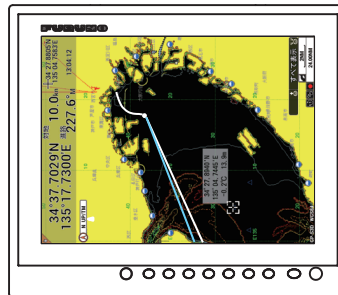

Install the monitor option as follows:

1. Unfasten four binding screws (M3×8) to remove the cable cover at the back of the display unit.  
The internal speaker cable is connected between the MAIN board and cable cover. If the internal speaker cable prevents your work, disconnect it from the MAIN board.

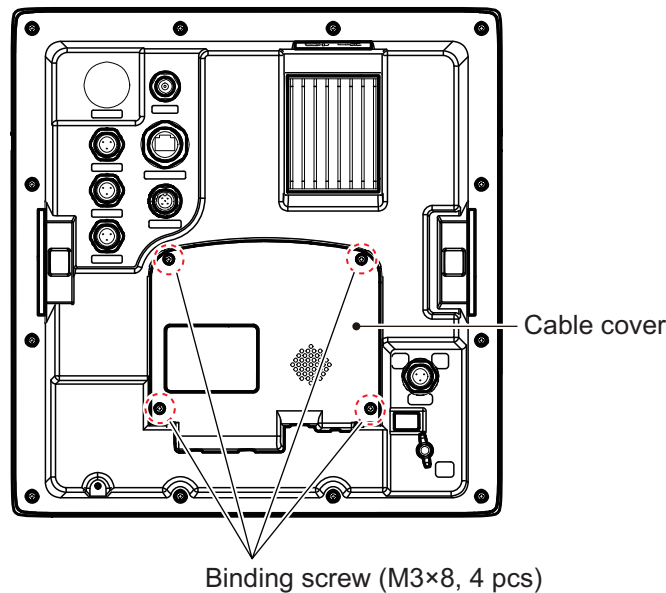

- Unfasten the two screws indicated on the following figure.

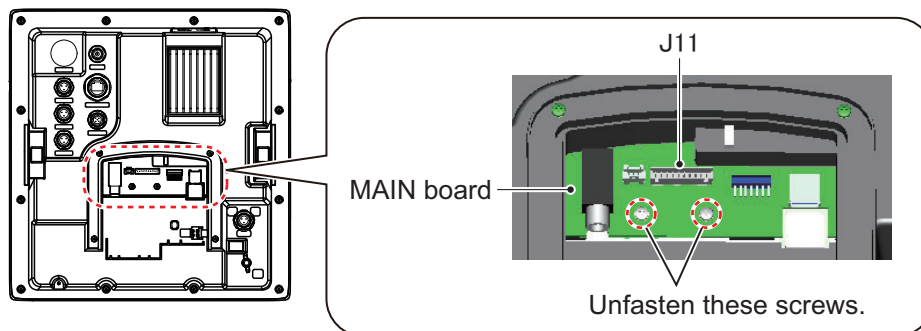

- Connect the XHP-10 connector of the monitor option to J11 on the MAIN board.
- Secure the monitor option to the MAIN board, using the two screws removed at step 2.

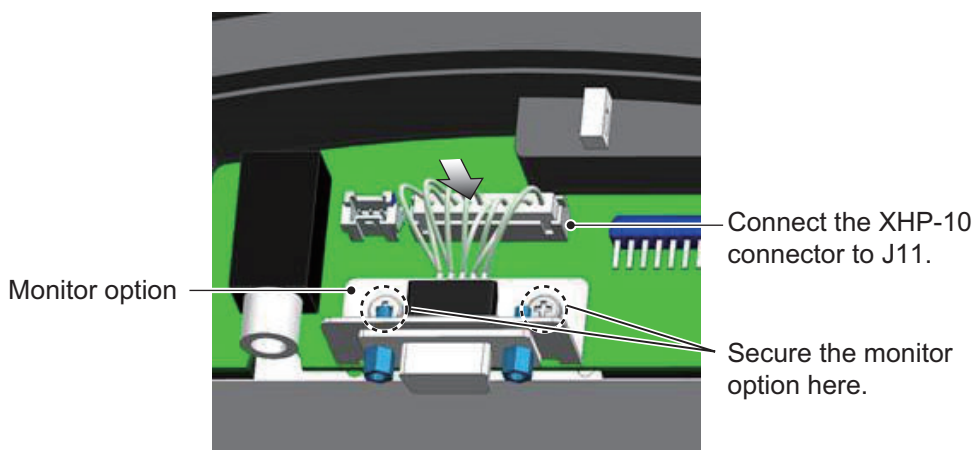

- Reattach the cable cover with four binding screws (M3×8).  
**Note:** When attaching the cable cover, take care that the internal speaker cable is not pinched between the unit and the cable cover.

# 2. WIRING

## 2.1 How to Connect the Unit

Connect the equipment, referring to the figure below and the interconnection diagram at the back this manual. Do not remove the waterproofing cap from unused connectors.

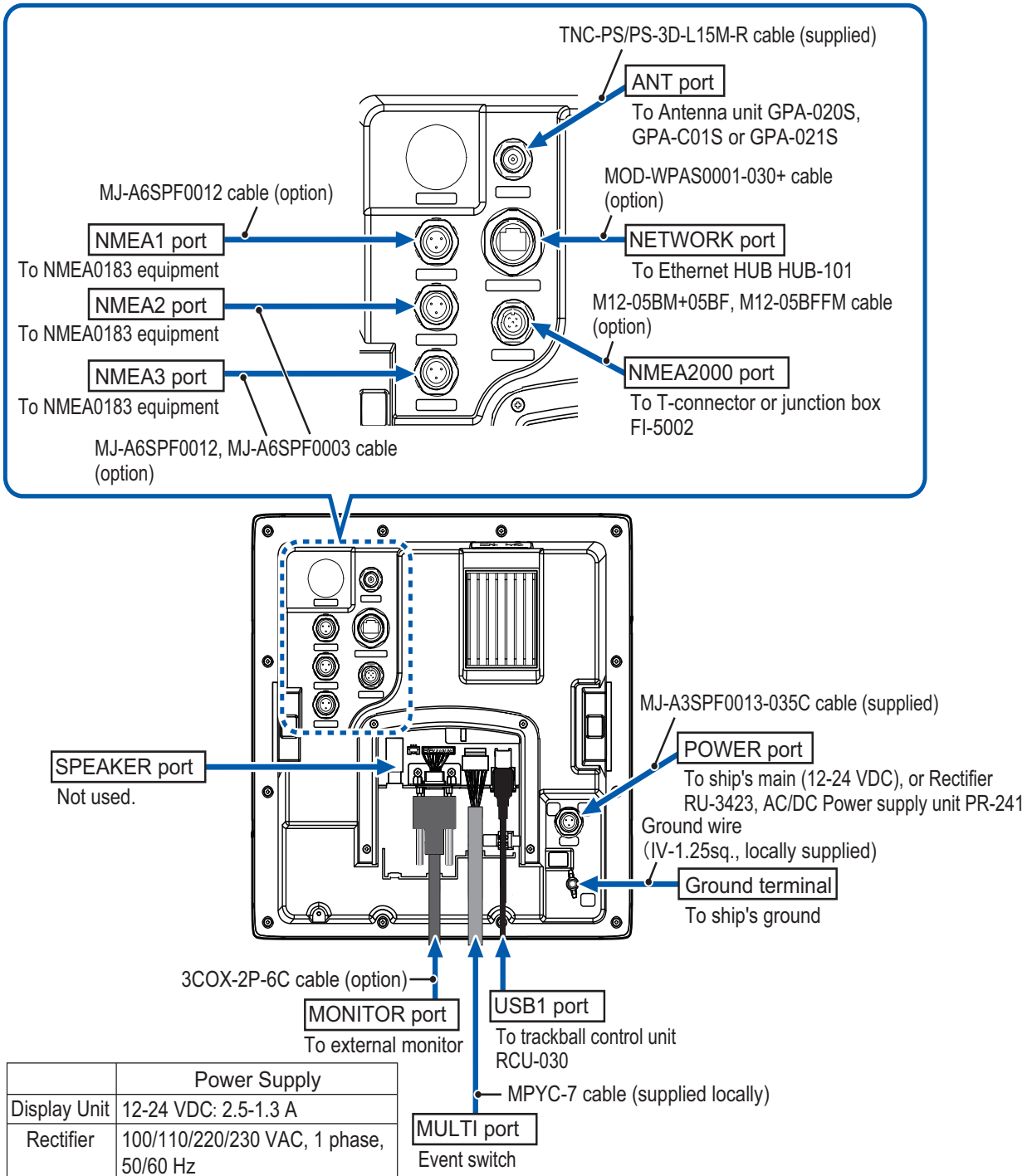

**Note:** There is USB2 port on the front of the display unit.



### 2.1.1 POWER port and grounding

Connect the ship's supply to the POWER port, using the supplied MJ-A3SPF0013-035C cable (3.5 m, one end connector).

Fasten the ground wire (locally supplied) to the ground terminal. The ground wire should be 1.25sq or larger.

**Note:** The fuse holder on the MJ-A3SPF0013-035C cable is not waterproof. Waterproof the fuse holder when the cable is run through places subject to water splash and rain.

### 2.1.2 ANT port

Connect the antenna unit to the ANT port, using the TNC-PS/PS-3D-L15M-R cable (15 m). The TNC-PS/PS-3D-L15M-R cable is supplied with the antenna unit.

Prepare the optional antenna cable assembly (30 m, 40 m and 50 m) to extend the distance between the display unit and antenna unit.

#### Antenna cable assembly

Type	Code No.	Remarks
CP20-01700	004-372-110	<ul style="list-style-type: none"> <li>• 30 m antenna cable (type: 8D-FB-CV, qty: 1)</li> <li>• 1 m adapter cable assembly (type: NJ-TP-3DXV-1, qty: 2)</li> </ul>
CP20-02700	004-381-160	<ul style="list-style-type: none"> <li>• 30 m antenna cable (type: 8D-FB-CV, qty: 1)</li> <li>• 1 m adapter cable assembly (type: NJ-TP-3DXV-1, qty: 1)</li> <li>• Coaxial connector adapter (type: TNCP-NJ, qty: 1)</li> </ul>
CP20-01720	001-207-980	<ul style="list-style-type: none"> <li>• 40 m antenna cable (type: 8D-FB-CV, qty: 1)</li> <li>• 1 m adapter cable assembly (type: NJ-TP-3DXV-1, qty: 2)</li> </ul>
CP20-02720	001-207-990	<ul style="list-style-type: none"> <li>• 40 m antenna cable (type: 8D-FB-CV, qty: 1)</li> <li>• 1 m adapter cable assembly (type: NJ-TP-3DXV-1, qty: 1)</li> <li>• Coaxial connector adapter (type: TNCP-NJ, qty: 1)</li> </ul>
CP20-01710	004-372-120	<ul style="list-style-type: none"> <li>• 50 m antenna cable (type: 8D-FB-CV, qty: 1)</li> <li>• 1 m adapter cable assembly (type: NJ-TP-3DXV-1, qty: 2)</li> </ul>
CP20-02710	004-381-170	<ul style="list-style-type: none"> <li>• 50 m antenna cable (type: 8D-FB-CV, qty: 1)</li> <li>• 1 m adapter cable assembly (type: NJ-TP-3DXV-1, qty: 1)</li> <li>• Coaxial connector adapter (type: TNCP-NJ, qty: 1)</li> </ul>

The coaxial connector (type: N-P-8DFB-1-CF, qty: 1), insulation tape (type: U-TAPE 0.5X19X5M, qty: 1) and vinyl tape (type: V360K01, qty: 1) are included in the antenna cable assembly indicated on the table above.

## 2. WIRING

### How to extend the antenna cable

Fabricate the end of the antenna cable and attach the coaxial connector, then connect the antenna cable as shown below.

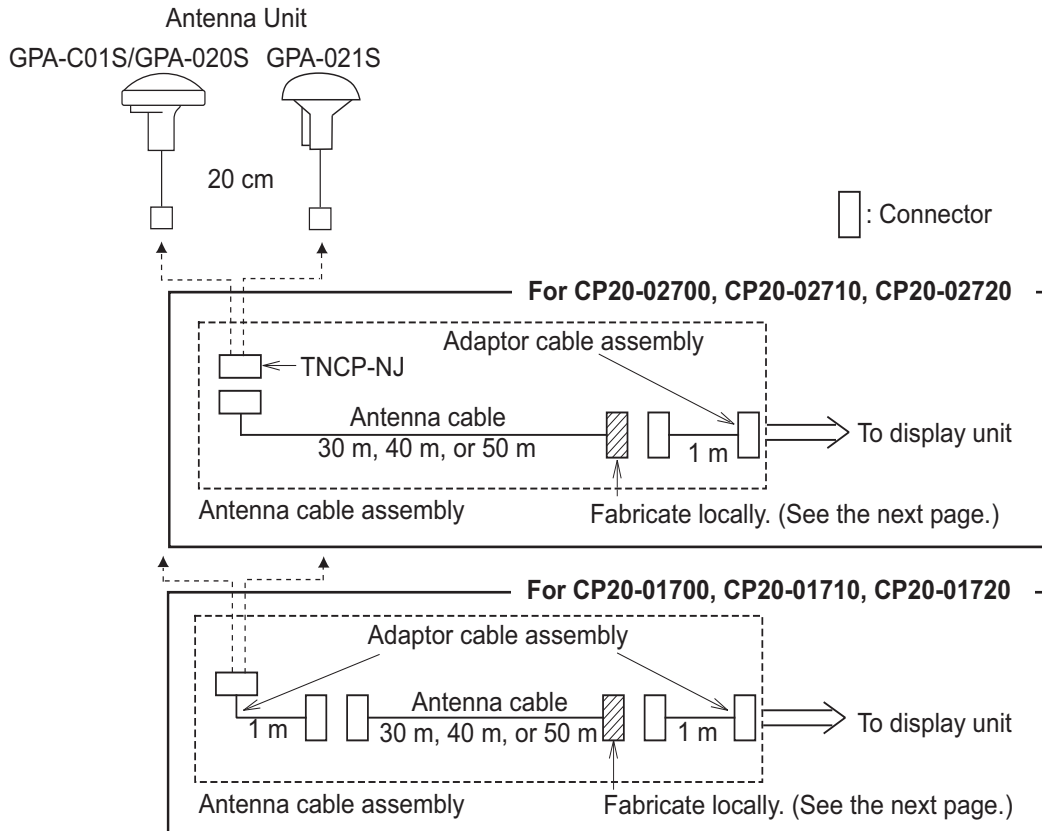

### Waterproofing the connector

Wrap the connector with vulcanizing tape, then vinyl tape. Bind the tape ends with cable ties.

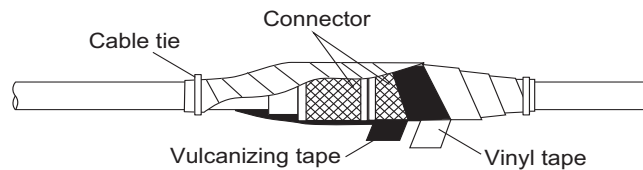

**How to attach the N-P-8DFB connector**

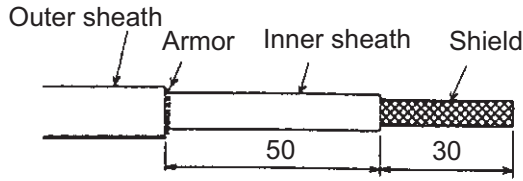

Remove outer sheath and armor by the dimensions shown left.  
Expose inner sheath and shield by the dimensions shown left.

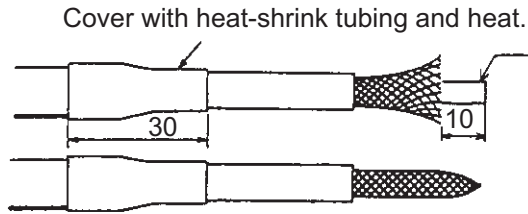

Cut off insulator and core by 10 mm.

Twist shield end.

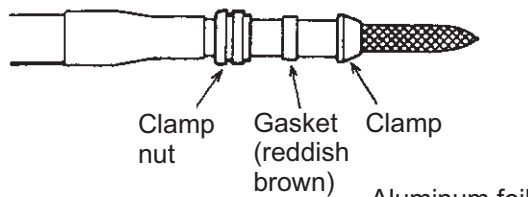

Slip on clamp nut, gasket and clamp as shown left.

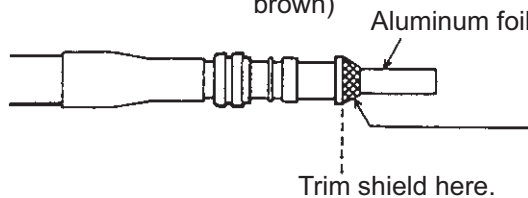

Fold back shield over clamp and trim.



Cut aluminum foil at four places, 90° from one another.

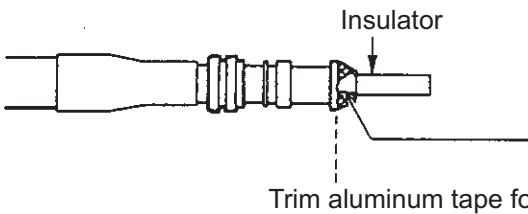

Fold back aluminum foil onto shield and trim.



Expose the insulator by 1 mm.

Expose the core by 5 mm.

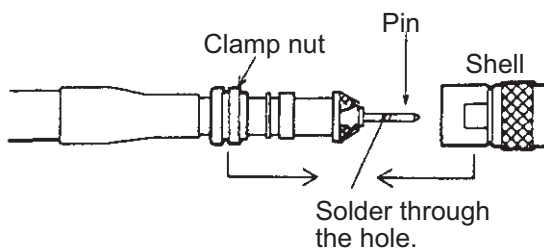

Slip the pin onto the core. Solder them together through the hole on the pin.

Insert the pin into the shell. Screw the clamp nut into the shell.  
(Tighten by turning the clamp nut. Do not tighten by turning the shell.)

## 2. WIRING

### 2.1.3 NMEA1/NMEA2/NMEA3 port

When you use NMEA0183 equipment (radar, autopilot, etc.), connect it to the NMEA1, NMEA2 or NMEA3 ports, using the following optional cable.

- MJ-A6SPF0012 cable (5 m, 10 m and 15 m): connectors at both ends
- MJ-A6SPF0003 cable (2 m, 5 m, 10 m and 15 m): single connector (Cable fabrication on the NMEA0183 equipment side is required.)

### 2.1.4 NETWORK port

To connect an AIS receiver or a radar, the Ethernet HUB HUB-101 (local supply) and the optional MOD-WPAS0001-030+ cable (3 m, w/waterproof modular plug) are required. Connect the Ethernet HUB to the NETWORK port (100Base-TX) on the Display Unit.

For LAN cable extension, prepare the optional joint box TL-CAT-012 and following LAN cable:

- MOD-Z072 cable (2 m, 5 m and 10 m): A modular plug is attached to each end of the cable (Cable fabrication is not required).
- FR-FTPC-CY cable (30 m: CP03-28920, 50 m: CP03-28930): LAN cable with armor. Fabricate the cable and attach the modular plugs, referring to the procedure on the following page.

**Note:** Do not connect equipment other than AIS receiver, radar and HUB-101 to the NETWORK port.

#### **How to fabricate the LAN cable**

Fabricate the LAN cable (FR-FTPC-CY) as shown in the following figure. Wrap both edges of the armor with vinyl tape. Confirm that the shield of the cable touches to the shell of the modular plug.

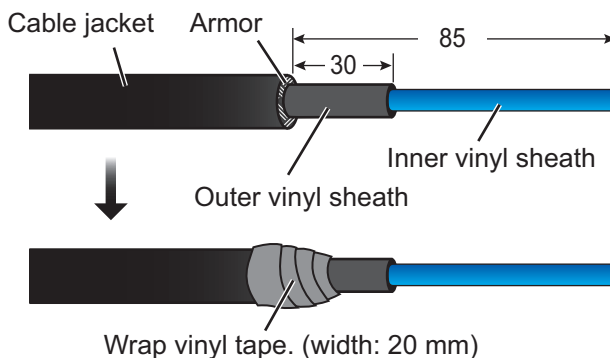



Expose inner vinyl sheath.



Remove the inner vinyl sheath by approx. 25 mm. Be careful not to damage inner shield and cores.

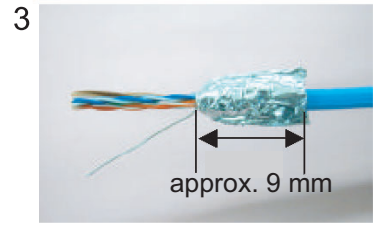

Fold back the shield, wrap it onto the inner vinyl sheath and cut it, leaving approx. 9 mm.

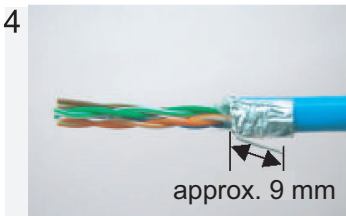

Fold back drain wire and cut it, leaving approx. 9 mm.

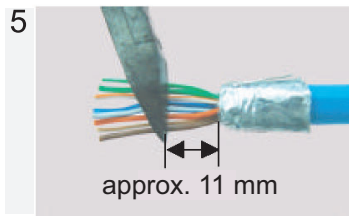

Straighten and flatten the cores in colored order and cut them, leaving approx. 11 mm.

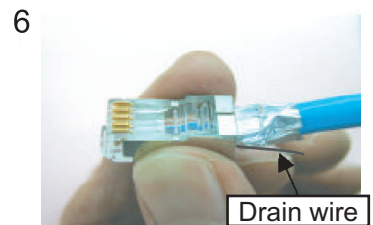

Insert the cable into the modular plug so that the folded part of the shield enters into the plug housing. The drain wire should be located on the tab side of the jack.



Using special crimping tool MPT5-8AS (PANDUIT CORP.), crimp the modular plug. Finally, check the plug visually.

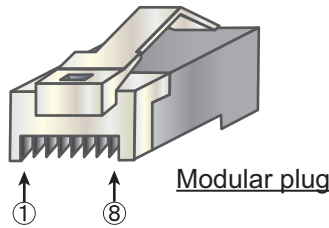

[Crossover cable]

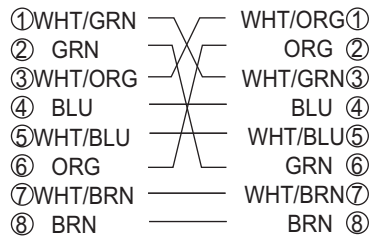

[Straight cable]

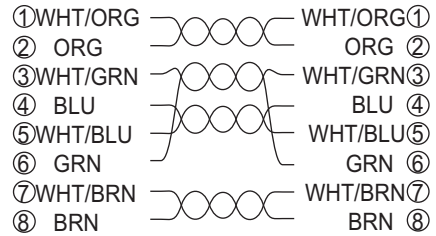

2. WIRING

**2.1.5 NMEA2000 port**

Use the optional M12-05BM+05BF cable (1 m, 2 m and 6 m, w/connectors) to connect the display unit to the NMEA2000 (CAN bus) network backbone. The display unit must be on the same network as NMEA2000 equipment used as data sources (autopilot, SATELLITE COMPASS™).

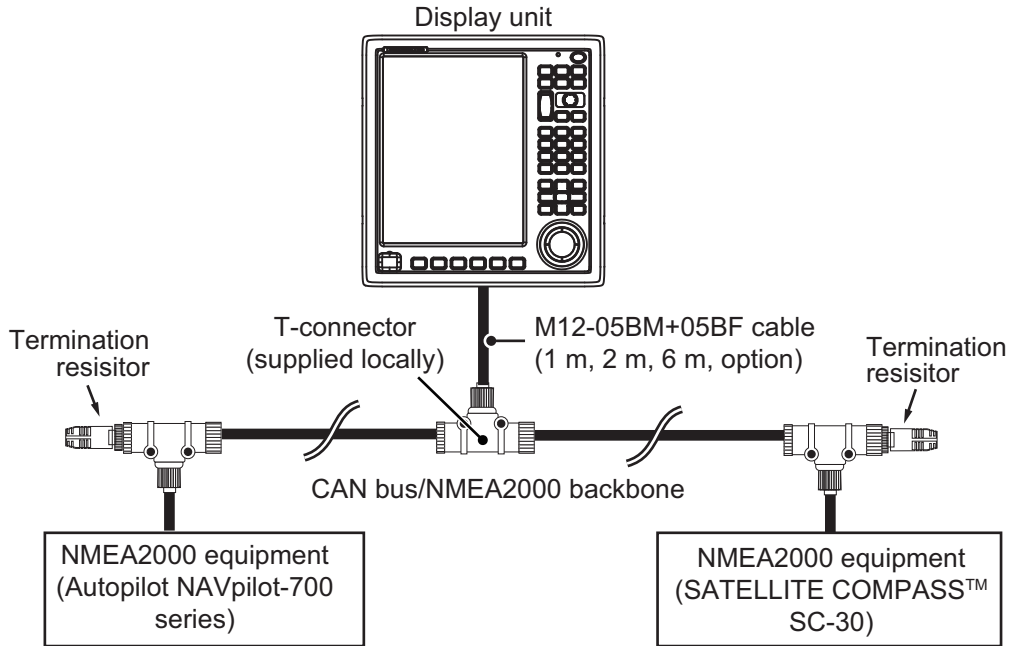

**Note 1:** The CAN bus is NMEA2000 compliant. Therefore, CAN bus equipment is available for GP-3700.

**Note 2:** The NMEA2000 (CAN bus) network requires a dedicated power supply. Turn the NMEA2000 network power on before you turn this equipment on.

**Note 3:** Termination resistors are required to close off the NMEA2000 (CAN bus) network ends, completing the network.

**How to connect to the Junction box FI-5002 (supplied locally)**

When using the FI-5002, connect the NMEA2000 port of the display unit to the FI-5002 internal MC connectors (CN3 to CN5), using the optional M12-05BFFM cable (1 m, 2 m and 6 m, one end connector).

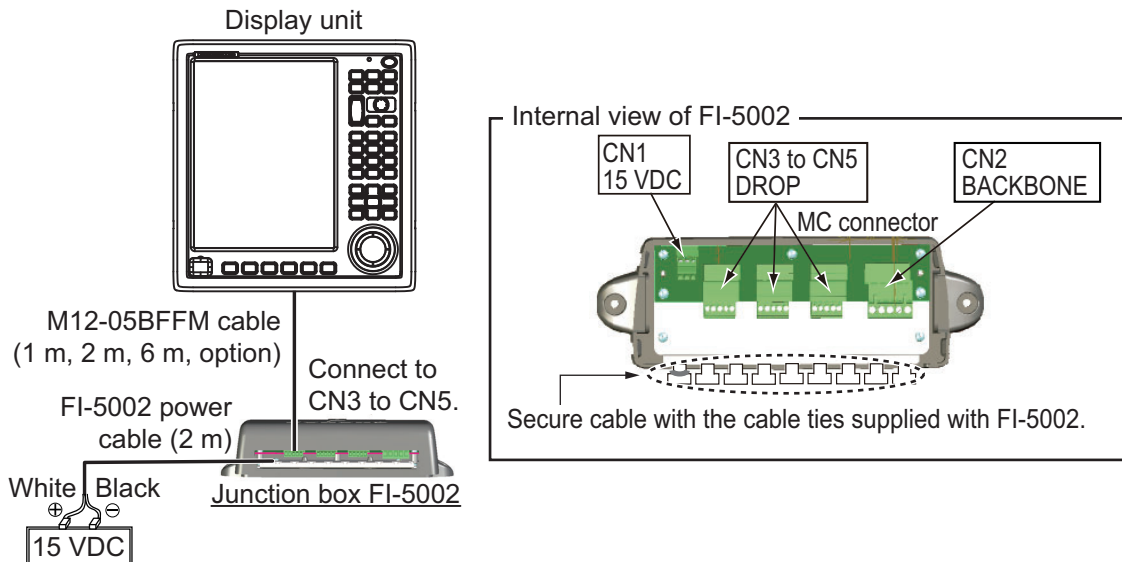

**How to fabricate the M12-05BFFM cable**

To connect the M12-05BFFM cable to FI-5002, fabricate the cable and attach the MC connector as shown in the following figure.

- How to fabricate the cable

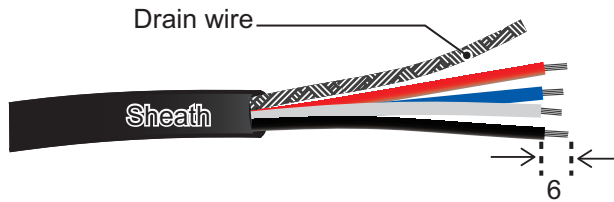

- How to attach the MC connector

CN3 to CN5		
Pin No.	Signal	Wire
1	SHIELD	Drain
2	NET-S	Red
3	NET-C	Black
4	NET-H	White
5	NET-L	Blue

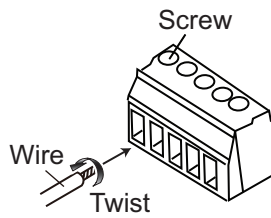

**How to insert cores**

1. Twist the cores.
2. Unfasten the screw with slotted screwdriver.
3. Insert the core to hole.
4. Tighten the screw with slotted screwdriver.
5. Pull the wire to confirm connection.

**Termination resistor in the FI-5002**

The FI-5002 has two termination resistors (R1 and R2). The resistors are set in the following manner:

- When no backbone cable is connected, R1 and R2 are set to ON position.
- When one backbone cable is connected, either R1 or R2 is set to ON position.
- When two backbone cables are connected, R1 and R2 are set to OFF position.

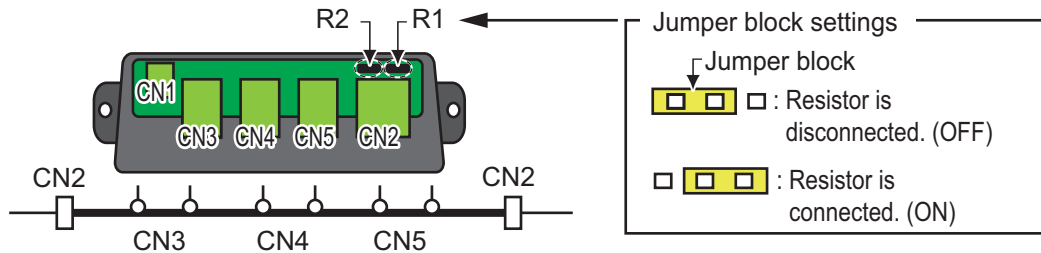

**2.1.6 MONITOR, MULTI, USB1 port**

**How to connect the cable**

The MONITOR, MULTI and USB1 ports are located inside the cable cover. Remove the cable cover and connect the cables as follows:

## 2. WIRING

1. Unfasten four binding screws (M3×8) to remove the cable cover at the back of the display unit.

The internal speaker cable is connected between the MAIN board and cable cover. If the internal speaker cable prevents your work, disconnect the cable from the MAIN board.

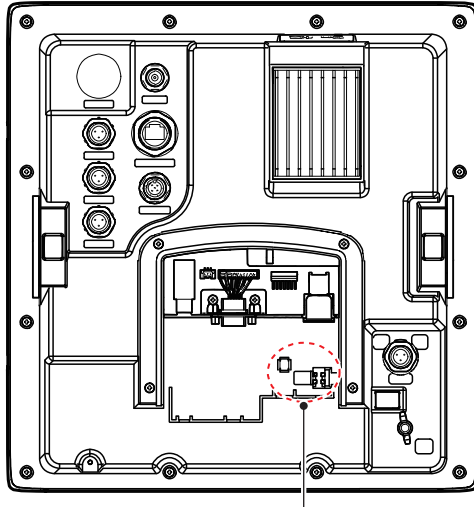

Secure the MPYC-7 and USB cable, using the cable tie.

2. Connect the cables to the appropriate port.
3. Secure the MPYC cable and USB cable to the cable clamp, using the supplied cable tie.

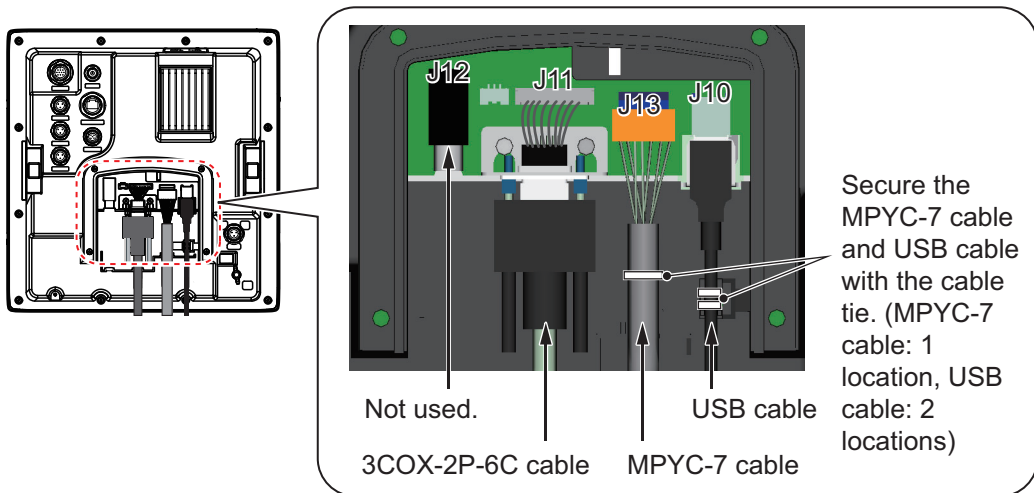

4. Reattach the cable cover with four binding screws (M3×8).

**Note:** When attaching the cable cover, take care that the internal speaker cable is not pinched between the unit and the cable cover.

### **MONITOR port (J11)**

You can connect a MU-150HD or a commercial monitor (resolution: SVGA) as an external monitor. The monitor option (type: OP14-82, option) and 3COX-2P-6C cable (5 m, 10 m, option) are required to use the MONITOR port (J11). Attach the monitor option (see section 1.4), then connect the external monitor with the 3COX-2P-6C cable.

### **MULTI port (J13)**

The MPYC-7 cable and NH connector, both supplied locally, are required to use the MULTI port (J13). Connect an event switch to the MULTI port (J13), referring the in-



terconnection diagram at the back this manual. Fabricate the MPYC-7 cable appropriately, according to the NH connector.

### **USB1 port (J10)**

Connect the optional trackball control unit RCU-030 (w/2 m cable) to the USB1 port (J10).

**Note 1:** There is USB2 port on the front on the display unit. Use the USB2 port to import/export data.

**Note 2:** Do NOT cut the USB cable for the trackball control unit.

## 2.2 DIP Switch Settings

There are two DIP switches (S1 and S2) on the MAIN board (14P0441) in the display unit. Keep the default setting.

### *Factory default setting on DIP switch S1*

1	2	3	4
OFF			

### *Factory default setting on DIP switch S2*

1	2	3	4
OFF			

## 2.3 Input/Output Data

The display unit can input/output NMEA0183 and NMEA2000 format data.

### 2.3.1 NMEA0183 format data

The display unit has three NMEA0183 ports (NMEA1/NMEA2/NMEA3). Input and output sentences change according to the [CONNECTED DEVICE] setting on the [PORT 1 (2 or 3) SETTING] menu (see the following tables). For how to set [CONNECTED DEVICE], see section 3.5.1.

#### **Input sentences**

#### *[CONNECTED DEVICE] is set to [NORMAL]*

Sentence	Data
CUR	Water Current Layer
DBK	Depth Below Keel
DBS	Depth Below Surface
DBT	Depth Below Transducer
DPT	Depth
GGA	Global Positioning System Fix Data
GLL	Geographic Position
GNS	GNSS Fix Data
HDG	Heading, Deviation & Variation

2. WIRING

Sentence	Data
HDM	Heading, Magnetic
HDT	Heading True
MTW	Water Temperature
MWV	Wind Speed and Angle
RMA	Recommended Minimum Specific Loran-C Data
RMB	Recommended Minimum Specific Navigation Information
RMC	Recommended Minimum Specific GNSS Data
THS	True Heading and Status
TLL	Target Latitude and Longitude
TTM	Tracked Target Message
VDR	Set & Drift
VHW	Water Speed and Heading
VTG	Course Over Ground & Ground Speed
VWR	Wind relative Bearing and Velocity
VWT	True Wind Speed and Angle
ZDA	Time & Date

*[CONNECTED DEVICE] is set to [RADIO EQUIPMENT]*

Sentence	Data
TTM	Tracked Target Message
TLL	Target Latitude and Longitude

*[CONNECTED DEVICE] is set to [AIS]*

Sentence	Data
ALR	Set alarm state
VDM	AIS VHF Data-link Message

*[CONNECTED DEVICE] is set to [GPS BUOY]*

Sentence	Data
<b>When using a GPS buoy</b>	
BLV	GPS Buoy Location
GLL	GPS Buoy Location (II, OM, LA, LC, DE)
TLL	GPS Buoy Location
<b>When using a GPS buoy as a sub ship</b>	
GGA, RMC, RMA, GLL	GPS Buoy Location (CV, other than II, OM, LA, LC, and DE)

*[CONNECTED DEVICE] is set to [AUTO PILOT]*

Sentence	Data
Furuno proprietary sentence	Autopilot information

*[CONNECTED DEVICE] is set to [RTCM]*

Sentence	Data
MSK	Receiver Interface Command
CRQ	Query Sentence

**Output sentences**

Sentence	Data	[CONNECTED DEVICE] setting					
		NORMAL	RADIO EQUIPMENT	AIS	GPS BUOY	AUOT PILOT	RTCM
AAM	Waypoint Arrival Alarm	✓	✓	✓	✓	✓	-
APB	Autopilot Sentence B	✓	✓	✓	✓	✓	-
BOD	Bearing Origin to Destination	✓	✓	✓	✓	✓	-
BWC	Bearing & Distance to Waypoint-Great Circle	✓	✓	✓	✓	✓	-
BWR	Bearing & Distance to Waypoint - Rhumb Line	✓	✓	✓	✓	✓	-
DBT	Depth Below Transducer	✓	✓	✓	✓	-	-
DPT	Depth	✓	✓	✓	✓	-	-
DTM	Datum Reference	✓	✓	✓	✓	-	-
GGA	Global Positioning System Fix Data	✓	✓	✓	✓	-	-
GLL	Geographic Position - Latitude/ Longitude	✓	✓	✓	✓	-	-
GNS	GNSS Fix Data	✓	✓	✓	✓	-	-
GSA	GNSS DOP and Active Satellites	✓	✓	✓	✓	-	-
GSV	GNSS Satellites in View	✓	✓	✓	✓	-	-
GTD	Geographical Position, Loran-C TDs	✓	✓	✓	✓	-	-
HDG	Heading, deviation and variation	✓	✓	✓	✓	-	-
HDT	Heading True	✓	✓	✓	✓	-	-
MSK	Receiver Interface Command	-	-	-	-	-	✓
MSS	MSK receiver signal status	-	-	-	-	-	✓
MTW	Water temperature	✓	✓	✓	✓	-	-
MWV	Wind speed and angle	✓	✓	✓	✓	-	-
RMA	Recommended minimum specific LORAN-C data	✓	✓	✓	✓	-	-

## 2. WIRING

Sentence	Data	[CONNECTED DEVICE] setting					
		NORMAL	RADIO EQUIPMENT	AIS	GPS BUOY	AUOT PILOT	RTCM
RMB	Recommended Minimum Navigation Information	✓	✓	✓	✓	✓	-
RMC	Recommended Minimum Specific GNSS Data	✓	✓	✓	✓	-	-
RTE	Routes RTE - Routes	✓	✓	✓	✓	✓	-
THS	True heading & status	✓	✓	✓	✓	-	-
TLL	Target Latitude and Longitude	✓	✓	✓	✓	-	-
TTM	Tracked target message	✓	✓	✓	✓	-	-
VHW	Water speed and heading	✓	✓	✓	✓	-	-
VTG	Course over ground & ground speed	✓	✓	✓	✓	✓	-
WPL	Waypoint Location	✓	✓	✓	✓	✓	-
XTE	Cross-Track Error, Measured	✓	✓	✓	✓	✓	-
ZDA	Time and date	✓	✓	✓	✓	-	-
pidat*	Product information	✓	✓	✓	✓	-	-
drcmd*	Sentence output control command	-	✓	-	-	-	-

\*: Furuno proprietary sentence

### 2.3.2 NMEA2000 format data

#### Input PGN

PGN	Data	Remarks
059392	ISO Acknowledgement	
059904	ISO Request	
060928	ISO Address Claim	
061184	Self Test Group Function	Proprietary PGN
126208	NMEA - Request group function	
	NMEA - Command group function	
	NMEA - Acknowledge group function	
126464	PGN List - Transmit PGN's group function	
126720	Memory Clear Group Function	Proprietary PGN
	Reset Group Function	Proprietary PGN
	Other Setting (Steering mode)	Proprietary PGN
126996	Product Information	
127237	Heading/Track Control	

PGN	Data	Remarks
127250	Vessel Heading	
129538	GNSS Control Status	
130577	Direction Data	
130816	Self Test Report	Proprietary PGN
130817	Furuno GNSS Control Group Function	Proprietary PGN
130818	Heading & Attitude Sensor Control Status	Proprietary PGN
130819	Motion Sensor Control Status	Proprietary PGN
130820	Motion Sensor Status	Proprietary PGN
130821	NAV Source Select	
130827	NAVpilot Display Data (High Speed)	

### Output PGN

PGN	Data	Remarks	Output cycle (msec)
059392	ISO Acknowledgement	For Certification Level A/B, Refusing output requirement	-
059904	ISO Request	For Certification Level A/B, Requiring output	-
060928	ISO Address Claim	For Certification Level A/B • Address autonomy • Receiving output requirement	-
061184	Self Test Group Function	Proprietary PGN Receiving output requirement	-
126208	NMEA - Request group function	For Certification Level A/+ $\alpha$ Receiving output requirement	-
	NMEA - Command group function	For Certification Level A/? $\alpha$ • Changing the setting of SC-30 • Changing the setting of NAVpilot-700	-
	NMEA - Acknowledge group function	For Certification Level A/+ $\alpha$ Sending the confirmation for NMEA-Request group function and NMEA-Command group function	-
126464	PGN List - Transmit PGN's group function	For Certification Level A/+ $\alpha$ Receiving output requirement	-
	PGN List - Received PGN's group function	For Certification Level A/+ $\alpha$ Receiving output requirement	-
126720	Memory Clear Group Function	Proprietary PGN Receiving output requirement	-
	Reset Group Function	Proprietary PGN Receiving output requirement	-
126992	System Time		1000
126993	Heartbeat		30000
126996	Product Information	For Certification Level A/B Receiving output requirement	-
127258	Magnetic Variation		1000
128267	Water Depth		1000
128275	Distance Log		1000
129025	Position, Rapid Update		100

2. WIRING

PGN	Data	Remarks	Output cycle (msec)
129026	COG & SOG, Rapid Update		250
129029	GNSS Position Data		1000
129033	Local Time Offset	<ul style="list-style-type: none"> <li>• Receiving output requirement</li> <li>• Changing the setting of Local Offset</li> </ul>	-
129283	Cross Track Error		1000
129284	Navigation Data		1000
129285	Navigation - Route/WP Information	<ul style="list-style-type: none"> <li>• Outputs when waypoint is set/changed (own ship's position is required)</li> <li>• Receiving output requirement</li> </ul>	-
129538	GNSS Control Status	Receiving output requirement	-
129539	GNSS DOPs		1000
130822	Unit Division Code	Proprietary PGN Fast packet (For FURUNO Product) Receiving output requirement	-
130823	Browser Control Status	Proprietary PGN Fast packet (For FURUNO Product) Receiving output requirement	-
130827	NAVpilot General Message) I AM NAV4 SERVER) (#4=02)	Proprietary PGN	5000

# 3. SETTING UP THE EQUIPMENT

This chapter shows you how to set up your system according to the equipment you have connected.

## Menu operation description

The basic operations to use during the installation setup are as follows:

1. Press **⏻/BRILL** key to turn the power on.
2. Press the **MENU** key to open the main menu.

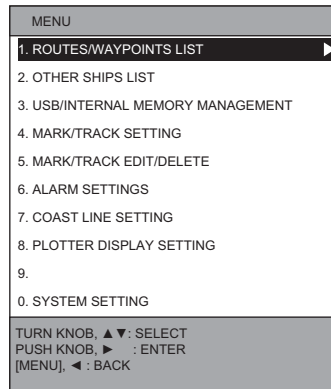

3. Select the menu item.  
There are three methods to select a menu item:
  - Press the appropriate numeric key (only for the numbered menu items).
  - Rotate the **ENTER** knob to move the cursor, then push the **ENTER** knob or press ►.
  - Press ▲ or ▼ to move the cursor, then push the **ENTER** knob or press ►.
4. Repeat step 3 to open the desired menu.
5. Select the menu item to change the setting value.
6. Change the setting value.  
There are two methods to change the setting value:
  - Rotate the **ENTER** knob to select the setting item, then push the **ENTER** knob.
  - Press ◀ or ► to select the setting item, then push the **ENTER** knob.
7. Press the **MENU** key several times or press the **DISP** key to close the menu.

**Note:** Unless noted otherwise, “select” means place the cursor on the desired menu item, then push the **ENTER** knob.

## 3.1 Language Setting

Select the language to use on your equipment as follows:

1. Press the **MENU** key to open the main menu.

### 3. SETTING UP THE EQUIPMENT

2. Select [0. SYSTEM SETTING].

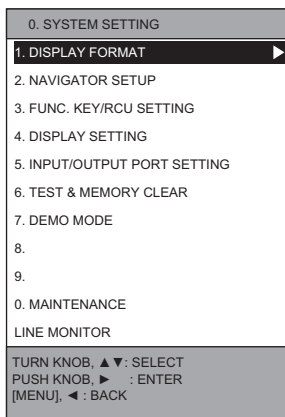

3. Select [1. DISPLAY FORMAT].  
The [DISPLAY FORMAT] menu has six pages. When the page 1 is not displayed, press the **1** key (or ◀, ▶) to open page 1.

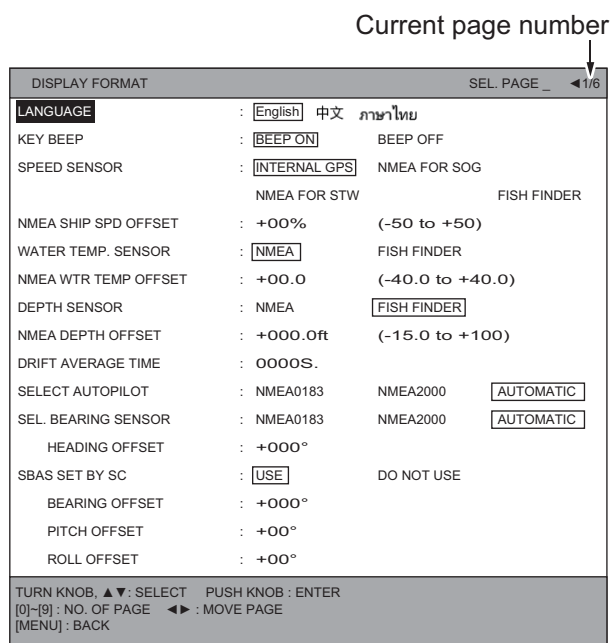

*[DISPLAY FORMAT] menu, page 1*

4. Select [LANGUAGE].
5. Select the appropriate language to use.
6. Press the **DISP** key to close the menu.

## 3.2 NMEA Equipment Setting

Setup the NMEA equipment connected to this equipment as follow:

1. Press the **MENU** key to open the main menu.
2. Select [0. SYSTEM SETTING].
3. Select [1. DISPLAY FORMAT].  
The [DISPLAY FORMAT] menu has six pages. When the page 1 is not displayed, press the **1** key (or ◀, ▶) to open page 1.
4. Select [SPEED SENSOR].



5. Select the ship's speed data source.
  - [INTERNAL GPS]: Use the internal GPS data.
  - [NMEA FOR SOG]: Use the VTG, RMC or RMA sentence data from the NMEA0183 equipment.
  - [NMEA FOR STW]: Use the VHW sentence data from the NMEA0183 equipment.
  - [FISH FINDER]: Not used.
6. Offset the ship's speed value.
 

**Note:** Normally, offset the value from equipment used as the data source. If the data source does not have an offset function, enter the offset value from this equipment.

  - 1) Select [NMEA SHIP SPD OFFSET].
  - 2) Press the appropriate numeric key to enter the offset value.  
For example, if the speed indication is 10% lower than actual speed, enter "+10".
7. Select [WATER TEMP. SENSOR].
8. Select [NMEA].
  - [NMEA]: Use the MTW sentence data from the NMEA0183 equipment.
  - [FISH FINDER]: Not used.
9. Offset the water temperature value on [NMEA WTR TEMP OFFSET], referring to step 6.
10. Select [DEPTH SENSOR].
11. Select [NMEA].
  - [NMEA]: Use the DPT, DBT, DBK or DBS sentence data from the NMEA0183 equipment.
  - [FISH FINDER]: Not used.
12. Offset the depth value on [NMEA DEPTH OFFSET], referring to step 6.
13. Select [AUTOPILOT] when an autopilot is connected to the display unit.
14. Select the data format of the autopilot.
  - [NMEA0183]: Use the NMEA0183 sentences to communicate with the autopilot.
  - [NMEA2000]: Use the NMEA2000 PGNs to communicate with the autopilot.
  - [AUTOMATIC]: Switch the data automatically in specified priority. For the priority, see the table at step 16.
15. Select [SEL. BEARING SENSOR] when a heading sensor is connected to the display unit.
16. Select the heading data format.
  - [NMEA0183]: Use the NMEA0183 sentences to communicate with the heading sensor.
  - [NMEA2000]: Use the NMEA2000 PGNs to communicate with the heading sensor.
  - [AUTOMATIC]: Switch the data automatically in specified priority. For the priority, see the following table.

### 3. SETTING UP THE EQUIPMENT

Priority	Equipment
1 (High priority)	Main heading sensor or autopilot set on the [SHOW NMEA2000 DEVICES] menu (see section 3.5.3).
2	Heading sensor or autopilot which is not set as main equipment on the [SHOW NMEA2000 DEVICES] menu.
3	Heading sensor or autopilot connected to the NMEA1 port.
4	Heading sensor or autopilot connected to the NMEA2 port.
5 (Low priority)	Heading sensor or autopilot connected to the NMEA3 port.

17. Offset the heading data on [HEADING OFFSET], referring step 6.
18. Select [SBAS SET BY SC] when a SATELLITE COMPASS™ is connected to NMEA2000 (CAN bus) backbone.
19. Select [USE] to use the SBAS satellites which are used by the SATELLITE COMPASS™.
20. Adjust [BEARING OFFSET], [PITCH OFFSET] and [ROLL OFFSET] as necessary, to offset the heading, pitch and roll value from SATELLITE COMPASS™.
21. Press the **DISP** key to close the menu.

## 3.3 Own Ship Information Setting

Enter own ship information (ship's width/length, antenna position, etc) as follows:

### Setting on the [DISPLAY FORMAT] menu

1. Press the **MENU** key to open the main menu.
  2. Select [0. SYSTEM SETTING].
  3. Select [1. DISPLAY FORMAT].
- The [DISPLAY FORMAT] menu has six pages. Press the **4** key (or ◀, ▶) to open page 4.

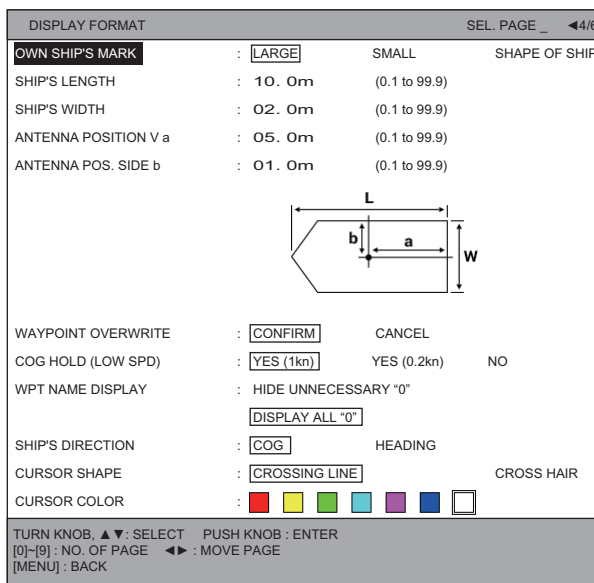

*[DISPLAY FORMAT] menu, page 4*

4. Select [SHIP'S LENGTH].

5. Press the appropriate numeric key to enter the ship's length ("L" indicated in the figure shown to the right).
6. Select [SHIP'S WIDTH].
7. Press the appropriate numeric key to enter the ship's width ("W" indicated in the figure at step 5).
8. Select [ANTENNA POSITION V a].
9. Press the appropriate numeric key to enter the antenna position ("a" indicated in the figure at step 5).
10. Select [ANTENNA POS. SIDE b].
11. Press the appropriate numeric key to enter the antenna position ("b" indicated in the figure at step 5).
12. Press the **DISP** key to close the menu.

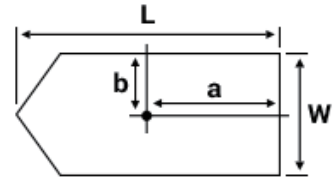

**Setting on the [NAVIGATOR SETUP] menu**

1. Press the **MENU** key to open the main menu.
2. Select [0. SYSTEM SETTING].
3. Select [2. NAVIGATOR SETUP].  
The [NAVIGATOR SETUP] menu has two pages. Press the **1** key (or ◀, ▶) to open page 1.

NAVIGATOR SETUP		SEL. PAGE _ ◀1/2	
SELECT NAV SOURCE	: [INTERNAL]	GPS	LORAN C
	ALL		
TIME DIFFERENCE	: +9 : 00		
NMEA TIME DIFFERENCE	: +00 : 00		
DATUM	: [WGS-84]	TOKYO	
POSITION SMOOTHING	: 000		
SPEED SMOOTHING	: 000		
SPEED AVERAGING	: 060		
NMEA SPEED AVERAGING	: 060		
LATITUDE OFFSET	: 0.000' N		
LONGITUDE OFFSET	: 0.000' E		
DISABLE SATELLITE(GPS)	: ___ ___ ___		
ANTENNA HEIGHT	: 05m		
GPS FIX MODE	: 2D	[2D/3D]	
DGPS/SBAS	: DGPS	SBAS	AUTOMATIC
	[NO]		
DGPS/SBAS ALARM	: ON	[OFF]	
TURN KNOB, ▲▼: SELECT    PUSH KNOB : ENTER [0]-[9] : NO. OF PAGE    ◀▶ : MOVE PAGE [MENU] : BACK			

[NAVIGATOR SETUP] menu, page 1

NAVIGATOR SETUP		SEL. PAGE _ ◀2/2	
DGPS BEACON STATION	: [AUTOMATIC]	MANUAL	
FREQUENCY SETTINGS	: 320. 5kHz		
DGPS BAUD RATE	: 50	100	[200]
SBAS SATELLITE SEL.	: [AUTOMATIC]	MANUAL	
SBAS MAN. SAT. SET.	: 134		
DISABLE SATELLITE(SBAS)	: ___ ___ ___		
DISABLE SATELLITE(QZSS)	: ___ ___ ___		
COURSE UP REDRAW ANGLE	: 22.5°	(20.0 to 60.0)	
FREE UP ANGLE	: 000°		
COURSE SMOOTHING	: 000		
ROLLOVER	: 2015		
RTE SENTENCE *	: [LEGACY]	DNV	
TURN KNOB, ▲▼: SELECT    PUSH KNOB : ENTER [0]-[9] : NO. OF PAGE    ◀▶ : MOVE PAGE [MENU] : BACK			

[NAVIGATOR SETUP] menu, page 2

\*: Normally, select [LEGACY].

- [LEGACY]: Own ship's position data is included in the RTE sentence.
- [DNV]: Own ship's position data is not included in the RTE sentence.

4. Select [SELECT NAV SOURCE].
5. Select the position data source.
  - [INTERNAL]: Use the internal GPS data.
  - [GPS]: Use the NMEA0183 sentences.
  - [LORAN C]: Use the Loran C navigator data.
  - [ALL]: Select this option when you have multiple EPFS devices in your configuration (NMEA0183 sentences). The equipment having highest accuracy has priority.

### 3. SETTING UP THE EQUIPMENT

6. Select [ANTENNA HEIGHT].
7. Press the appropriate numeric key to enter the distance between the waterline and antenna position.
8. Press the **DISP** key to close the menu.

## 3.4 Event Switch Setting

When the event switch(es) is connected, assign the function for the event switch(es) as follows:

1. Press the **MENU** key to open the main menu.
2. Select [0. SYSTEM SETTING].
3. Select [1. DISPLAY FORMAT].  
The [DISPLAY FORMAT] menu has six pages. When the page 6 is not displayed, press the **6** key (or ◀, ▶) to open page 6.

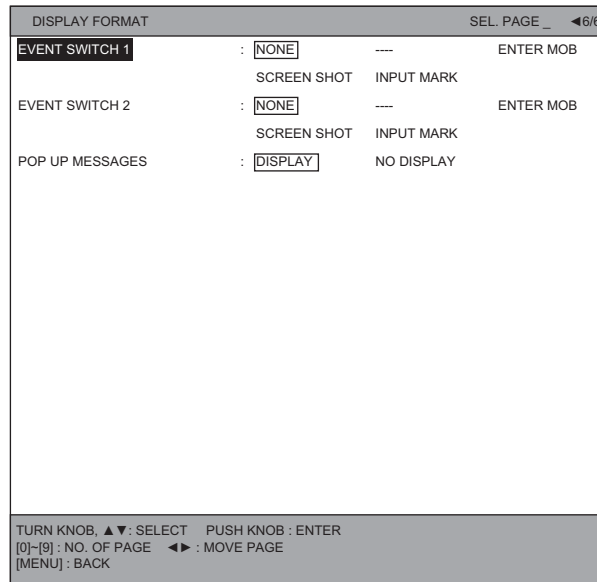

*[DISPLAY FORMAT] menu, page 6*

4. Select [EVENT SWITCH 1] or [EVENT SWITCH 2].
5. Select the function for the event switch.
  - [NONE]: The event switch is disabled.
  - [ENTER MOB]: Operate the switch to place the MOB mark at the current position.
  - [SCREEN SHOT]: Operate the switch to create a screen shot (image capture of the screen).
  - [INPUT MARK]: Operate the switch to place an event mark at the current position.
6. Press the **DISP** key to close the menu.

## 3.5 Input/Output Port Setting

### 3.5.1 Serial port setting

When the NMEA 1 to NMEA 3 ports are used to connect external navigation equipment, set up the ports according to the equipment connected.

#### Connected equipment setup

1. Press the **MENU** key to open the main menu.
2. Select [0. SYSTEM SETTING].
3. Select [5. INPUT/OUTPUT PORT SETTING].

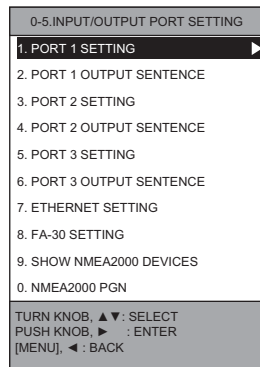

4. Select [1. PORT 1 SETTING].

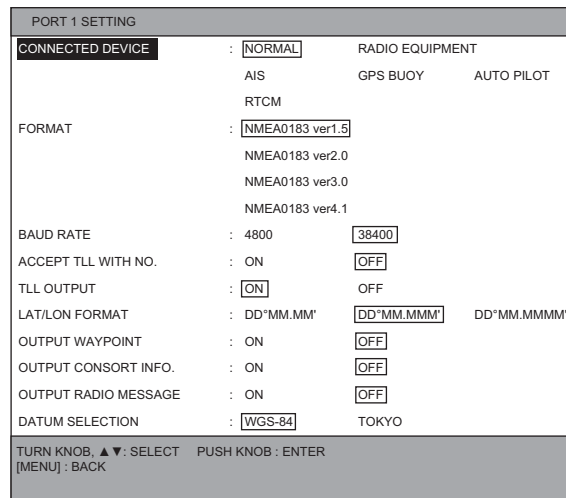

5. Select [CONNECTED DEVICE].
6. Select the equipment that is connected to the NMEA 1 port.  
The input/output sentences change according to the setting item here (see section 2.3.1).
  - [NORMAL]: Select this setting option for equipment other than the following equipment.
  - [RADIO EQUIPMENT]: Not used.
  - [AIS]: Imports the AIS information from the AIS.
  - [GPS BUOY]: Imports the GPS buoy information.
  - [AUTO PILOT]: Imports the autopilot information.
  - [RTCM]: Outputs the DGPS information with the RTCM SC-104 format.
7. Select [FORMAT].

### 3. SETTING UP THE EQUIPMENT

8. Select the NMEA0183 version for output. Select the appropriate version according to the connected equipment.
9. Select [BAUD RATE].
10. Select the output baud rate.
11. Select [ACCEPT TLL WITH NO.].
12. Select [ON] to register the TLL mark or the waypoint when receiving the TLL data with the target number from the connected radar. If not, select [OFF].
13. Select [TLL OUTPUT].
14. Select [ON] to output the latitude and longitude of the mark when a mark is entered. If not, select [OFF].
15. Select [LAT/LON FORMAT].
16. Select the output format for the position data (DD°MM.MM', DD°MM.MMM', DD°MM.MMMM').
17. Select [OUTPUT WAYPOINT].
18. Select [ON] to output the WPL and RTE sentence when a route is set as a destination. If not, select [OFF].
 

**Note:** When [RTE SENTENCE] is set to [DNV] on the [NAVIGATOR SETUP] menu, the RTE sentence is not output for routes that have only one waypoint.
19. Select [DATUM SELECTION].
20. Select the geodetic datum used on the external navigator.
21. Press the **MENU** key to go back to the [INPUT/OUTPUT PORT SETTING] menu.
22. Setup [3. PORT 2 SETTING] and [5. PORT 3 SETTING] in a similar manner.
23. Press the **DISP** key to close the menu.

#### Output sentence setting

1. Press the **MENU** key to open the main menu.
2. Select [0. SYSTEM SETTING].
3. Select [5. INPUT/OUTPUT PORT SETTING].
4. Select [2. PORT 1 OUTPUT SENTENCE].

The [PORT 1 OUTPUT SENTENCE] menu has two pages. Press ◀ or ▶ to move the page. The output sentences that can be turned on or off appear on this menu.

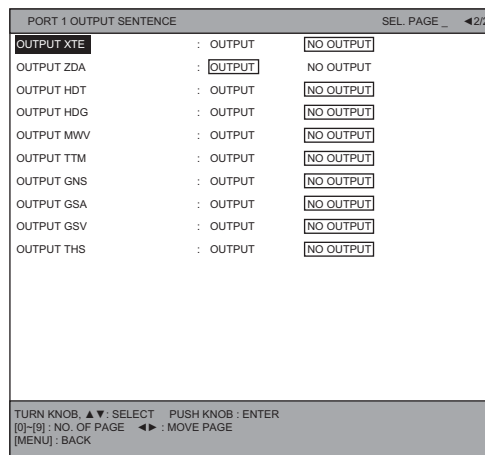
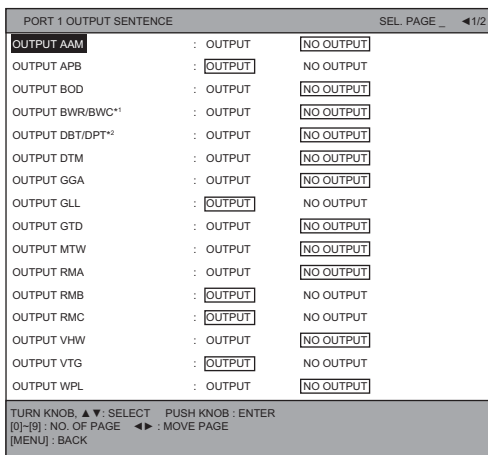

[PORT 1 OUTPUT SENTENCE] menu, page 1 [PORT 1 OUTPUT SENTENCE] menu, page 2

\*1: BWR: Output for rumblin navigation, BWC: Output for great circle navigation.  
 \*2: DBT: Output for NMEA0183 ver.1.5, DPT: Output for NMEA ver.2.0, 3.0 and 4.1.

5. Select the sentence to be set.
6. Select [OUTPUT] or [NO OUTPUT].
7. Repeat step 5 and step 6 to turn other sentences on or off.
8. Press the **MENU** key to go back to the [INPUT/OUTPUT PORT SETTING] menu.
9. Setup [4. PORT 2 OUTPUT SENTENCE] and [6. PORT 3 OUTPUT SENTENCE] in a similar manner.
10. Press the **DISP** key to close the menu.

### 3.5.2 NMEA2000 port setting

When this equipment is connected to the NMEA2000 network, select the PGNs to be output from the NMEA2000 port.

1. Press the **MENU** key to open the main menu.
2. Select [0. SYSTEM SETTING].
3. Select [5. INPUT/OUTPUT PORT SETTING].
4. Select [0. NMEA2000 PGN].

The [NMEA2000 PGN] menu has two pages. Press ◀ or ▶ to move the page. The output PGNs that can be turned on or off appear on this menu.

NMEA2000 PGN		SEL. PAGE	◀ 1/2
126992 OUTPUT SYSTEM TIME	: OUTPUT	NO OUTPUT	
127258 OUTPUT MAGNETIC VARIATION	: OUTPUT	[NO OUTPUT]	
128267 OUTPUT WATER DEPTH	: OUTPUT	[NO OUTPUT]	
128275 OUTPUT DISTANCE LOG	: OUTPUT	[NO OUTPUT]	
129025 OUTPUT POSN, RAPID UPDATE	: OUTPUT	[NO OUTPUT]	
129026 OUTPUT COG&SOG RAPID UPDATE	: [OUTPUT]	NO OUTPUT	
129029 OUTPUT GNSS POSITION DATA	: [OUTPUT]	NO OUTPUT	
129283 OUTPUT CROSS TRACK ERROR	: [OUTPUT]	NO OUTPUT	
129284 OUTPUT NAVIGATION DATA	: [OUTPUT]	NO OUTPUT	
129285 OUTPUT NAV-ROUTE/ WP INFO	: [OUTPUT]	NO OUTPUT	
TURN KNOB, ▲▼: SELECT    PUSH KNOB: ENTER [0]–[9]: NO. OF PAGE    ◀▶: MOVE PAGE [MENU]: BACK			

NMEA2000 PGN		SEL. PAGE	◀ 2/2
129538 OUTPUT GNSS CONTROL STATUS	: OUTPUT	[NO OUTPUT]	
129539 OUTPUT GNSS DOPS	: OUTPUT	[NO OUTPUT]	
TURN KNOB, ▲▼: SELECT    PUSH KNOB: ENTER [0]–[9]: NO. OF PAGE    ◀▶: MOVE PAGE [MENU]: BACK			

*[NMEA2000 PGN] menu, page 1*

*[NMEA2000 PGN] menu, page 2*

5. Select the PGN to be set.
6. Select [OUTPUT] or [NO OUTPUT].
7. Repeat step 5 and step 6 to turn other sentences on or off.
8. Press the **DISP** key to close the menu.

### 3.5.3 NMEA2000 equipment list

You can check the information of equipment on the NMEA2000 network. Do as follows to show the information:

1. Press the **MENU** key to open the main menu.
2. Select [0. SYSTEM SETTING].
3. Select [5. INPUT/OUTPUT PORT SETTING].



### 3. SETTING UP THE EQUIPMENT

- Select [9. SHOW NMEA2000 DEVICES].

SHOW NMEA2000 DEVICES				SEL. PAGE	1/1
SA	SET	USE	Model ID	Serial Code	LEN
1			SC-30	98765-43210	10
2			PG-700	12123434	3
					LEN(ALL) : 14
ROTATE KNOB, ▲▼ : SELECT    PUSH KNOB : SHOW DETAILS [MARK COLOR] : SET AS MAIN HEADING SENSOR [TRACK COLOR] : SET AS MAIN AUTO PILOT					

- Select the device, then do the either one of the following operations:
  - Push the **ENTER** knob: Shows detailed equipment information.
  - Press the **MARK COLOR** key: Set as the main heading sensor.
  - Press the **TRACK COLOR** key: Set as the main autopilot.

The following icons appear on the [SET] and [USE] column. The icons and their meaning are listed in the following table.

Icon	Meaning	Color
	<b>SET:</b> Main heading sensor	Same as character color
	<b>USE:</b> Heading sensor that is currently used.	Orange
	<b>SET:</b> Main autopilot	Same as character color
	<b>USE:</b> Autopilot that is currently used.	Orange
	<b>SET:</b> Main heading sensor and autopilot	Same as character color
	<b>USE:</b> Heading sensor and autopilot that is currently used.	Orange

- Press the **DISP** key to close the menu.

#### 3.5.4 Ethernet setting

When the HUB-101 is connected to the NETWORK port, do the Ethernet network setting as follows:

- Press the **MENU** key to open the main menu.
- Select [0. SYSTEM SETTING].
- Select [5. INPUT/OUTPUT PORT SETTING].
- Select [7. ETHERNET SETTING].

ETHERNET SETTING	
IP ADDRESS	: 172. 031. 014. 006
SUBNET MASK	: 255. 255. 000. 000
DEFAULT GATEWAY	: 000. 000. 000. 000
FA-30 IP ADDRESS	: 172. 031. 024. 002
TURN KNOB, ▲▼ : SELECT    PUSH KNOB : ENTER [MENU] : BACK	

- Select [IP ADDRESS].
- Press the appropriate numeric key to enter the IP address for your equipment.
 

**Note:** Be sure the IP address is not the same as other equipment on the network.
- Select [SUBNET MASK].
- Press the appropriate numeric key to enter the subnet mask for your equipment.



9. Select [DEFAULT GATEWAY].
10. Press the appropriate numeric key to enter the default gateway for your equipment.
11. When the FA-30 is connected through the HUB-101, select [FA-30 IP Address] and press the numeric key to enter the IP address of the FA-30.
12. Press the **DISP** key to close the menu.

### 3.5.5 FA-30 setting

When a FURUNO FA-30 is connected to this equipment, you can set up the FA-30 from this equipment.

1. Press the **MENU** key to open the main menu.
2. Select [0. SYSTEM SETTING].
3. Select [5. INPUT/OUTPUT PORT SETTING].
4. Select [8. FA-30 SETTING].

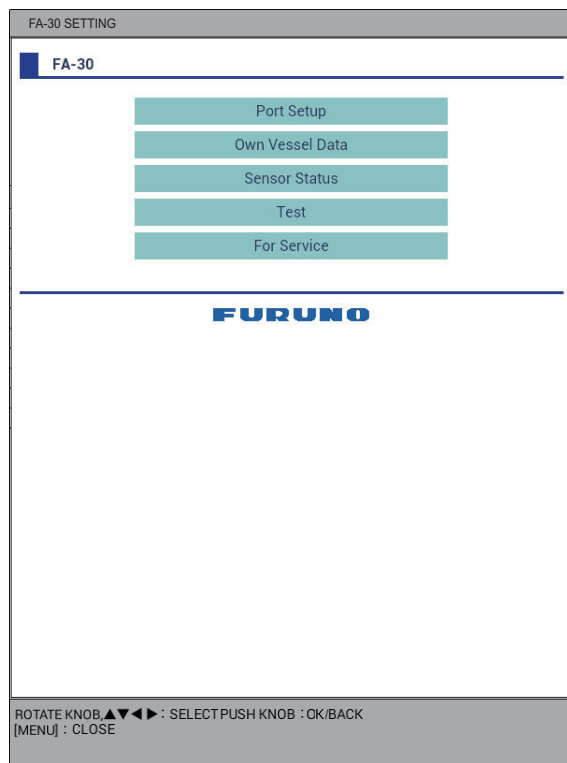

5. Set each item referring to the operator's manual of the FA-30.
6. Press the **DISP** key to close the menu.

### 3. SETTING UP THE EQUIPMENT

## 3.6 DGPS Setting

When the beacon receiver is installed in the display unit, do the DGPS setting as follows:

### 3.6.1 DGPS station selection

DGPS reference station can be searched for automatically (default) or manually. When the auto search takes more than five minutes to fix the DGPS position, use the manual search. To use the manual search, do as follows:

1. Press the **MENU** key to open the main menu.
2. Select [0. SYSTEM SETTING].
3. Select [2. NAVIGATOR SETUP].  
The [NAVIGATOR SETUP] menu has two pages. Press the **2** key (or ◀, ▶) to open page 2.

NAVIGATOR SETUP		SEL. PAGE _ ◀2/2
DGPS BEACON STATION	: AUTOMATIC	MANUAL
FREQUENCY SETTINGS	: 320. 5kHz	
DGPS BAUD RATE	: 50	100 200
SBAS SATELLITE SEL.	: AUTOMATIC	MANUAL
SBAS MAN. SAT. SET.	: 134	
DISABLE SATELLITE(SBAS)	: _ _ _	
DISABLE SATELLITE(QZSS)	: _ _ _	
COURSE UP REDRAW ANGLE	: 22.5°	(20.0 to 60.0)
FREE UP ANGLE	: 000°	
COURSE SMOOTHING	: 000	
ROLLOVER	: 2015	
RTE SENTENCE	: LEGACY	DNV

TURN KNOB, ▲▼: SELECT    PUSH KNOB: ENTER  
[0]-[9]: NO. OF PAGE    ◀▶: MOVE PAGE  
[MENU]: BACK

4. Select [DGPS BEACON STATION].
5. Select [MANUAL].
6. Select [FREQUENCY SETTINGS].
7. Press the numeric key to enter the frequency of the DGPS reference station which is the nearest to own ship.
8. Select [DGPS BAUD RATE].
9. Select the transmission rate of the DGPS reference station (50, 100 or 200 bps).
10. Press the **DISP** key to close the menu.

### 3.6.2 DGPS operation checking

You can check the DGPS operation as follows:

1. Press the **MENU** key to open the main menu.
2. Select [8. PLOTTER DISPLAY SETTING].

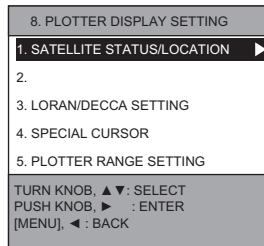

3. Select [1. SATELLITE STATUS/LOCATION].  
The [SATELLITE STATUS/LOCATION] window appears.

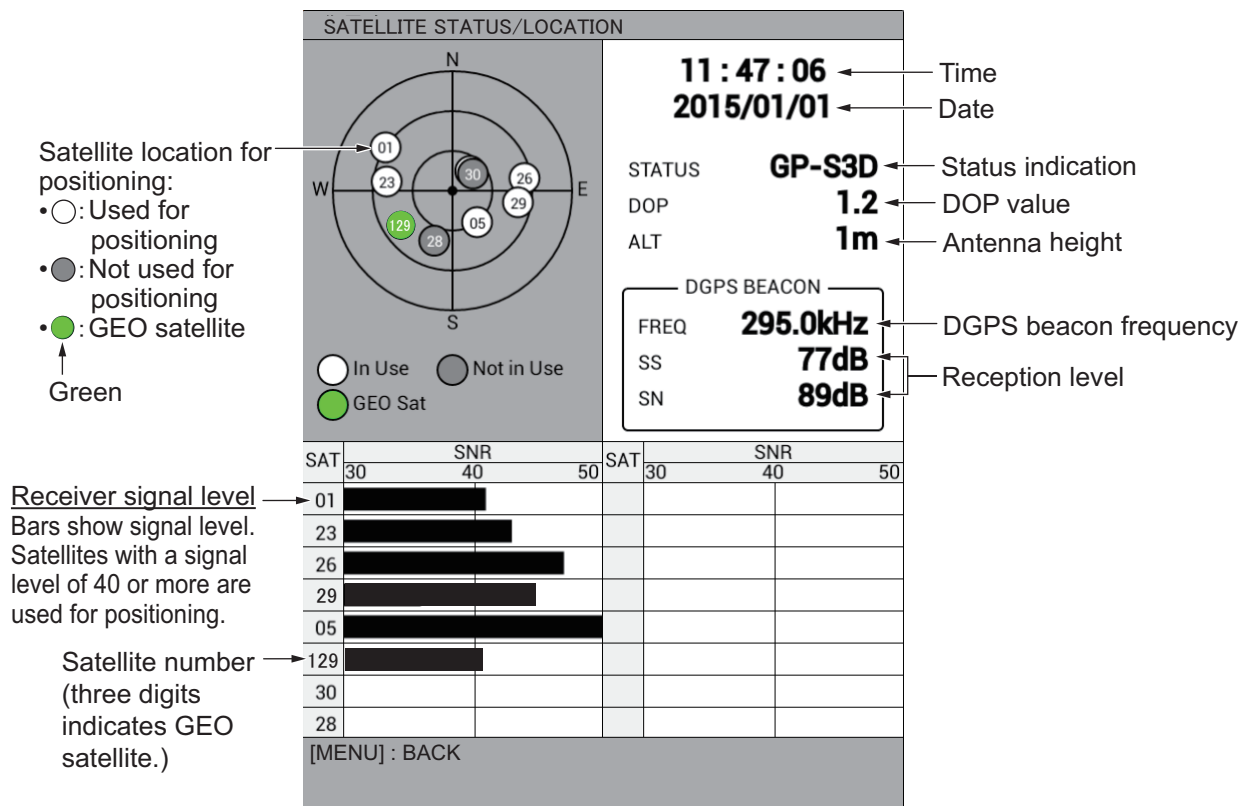

- **SS (Signal Strength):** Shows the electric field intensity of the beacon signal. The higher the value the stronger the signal. The value is normally 60 dB or more. Note that noise may be included in the receive frequency band regardless of higher value.
- **SN (Signal Noise):** Shows the signal-to-noise ratio of the received beacon signal. The higher the value the better the signal. The value is normally 21 dB or more.

4. Press the **DISP** key to close the [SATELLITE STATUS/LOCATION] window.

## 3.7 How to Control Charts

This section shows you how to install or update charts.

### 3.7.1 How to install charts

**Note:** Save the chart data to a USB flash memory first. You do not need to create a folder.

1. Connect the USB flash memory with chart data to the USB drive.
2. Press the **MENU** key to open the main menu.
3. Select [0. SYSTEM SETTING].
4. Select [0. MAINTENANCE].
5. Select [3. UPDATE CHART]. The message as shown in the right figure appears.

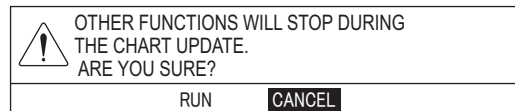

6. Select [RUN]. The message "PROCESSING. PLEASE WAIT." appears, then the [CHART ADMINISTRATION] menu appears.

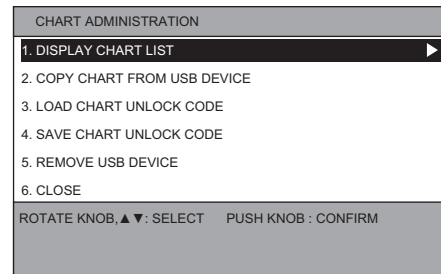

7. Select [2. COPY CHART FROM USB DEVICE] to display the list for data in the USB flash memory.

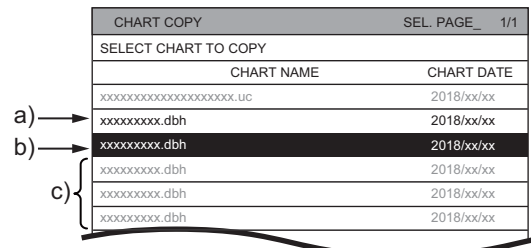

- a) Selected file (The letters are displayed in the color selected on the [BKGD/LETTER COLOR] menu.)
- b) Current selected position (The background is displayed in the reverse color to that selected on the [BKGD/LETTER COLOR] menu.)
- c) Non-selected file

8. Select all charts to be installed.
9. Select [SELECT CHART TO COPY]. The confirmation message appears.
10. Select [RUN] to start copying the charts. The estimate of the copying time is approx. 13 minutes 30 seconds at approx. 10 GB.
11. Push the **ENTER** knob.
12. Do one of the following methods to unlock the chart data.

How to unlock the chart data automatically

**Note:** Save the unlock code to the USB flash memory first. The file extension is "uc".

- 1) Select [3. LOAD CHART UNLOCK CODE] in the [CHART ADMINISTRATION] menu to display the list for data in the USB flash memory.
- 2) Select the file for the unlock code. The confirmation message appears.
- 3) Select [RUN]. The message "UNLOCK CODE VERIFIED." appears.
- 4) Push the **ENTER** knob.

How to unlock the chart data manually

- 1) Select [1. DISPLAY CHART LIST] in the [CHART ADMINISTRATION] menu to display the chart list.
- 2) Select the locked chart data (displayed with red letters), then press the **CURSOR ON/OFF** key to display the character entry window.
- 3) Set the unlock code as described below.  
Rotate the **ENTER** knob to select a character, then push the knob to confirm selection. Repeat this step to select all other characters. Select [ENTER] then push the knob.  
The message "UNLOCK CODE VERIFIED." appears.
- 4) Push the **ENTER** knob.
13. When unlocking the chart data automatically, select [5. REMOVE USB DEVICE]. The message "USB DEVICE CAN BE SAFELY REMOVED." appears. Push the **ENTER** knob then remove the USB device.
14. Select [6. CLOSE]. The confirmation message appears.
15. Select [RUN]. The system restarts.

**3.7.2 How to update charts**

**Note 1:** Save the chart data to a USB flash memory first. You do not need to create a folder.

**Note 2:** Before updating charts, delete the old chart data. If needed, take backups for an unlock code.

1. Connect the USB flash memory with chart data on it in the USB drive.
2. Press the **MENU** key to open the main menu.
3. Select [0. SYSTEM SETTING].
4. Select [0. MAINTENANCE].
5. Select [3. UPDATE CHART]. The message as shown in the right figure appears.
6. Select [RUN]. The message "PROCESSING. PLEASE WAIT." appears, then the [CHART ADMINISTRATION] menu appears. When taking backups for an unlock code (saving an unlock code to a USB flash memory), go to step 7. Otherwise, go to step 10.
7. Select [4. SAVE CHART UNLOCK CODE]. The confirmation message appears.
8. Select [RUN]. The message "RECORDING FINISHED" appears.
9. Push the **ENTER** knob.
10. Select [1. DISPLAY CHART LIST] to display the chart list.
11. Select the chart data to delete then press the **CANCEL** key.
12. Select [RUN]. The message "CHART DELETION COMPLETE" appears.
13. Push the **ENTER** knob.
14. Follow steps 7 to 15 in paragraph 3.7.1.

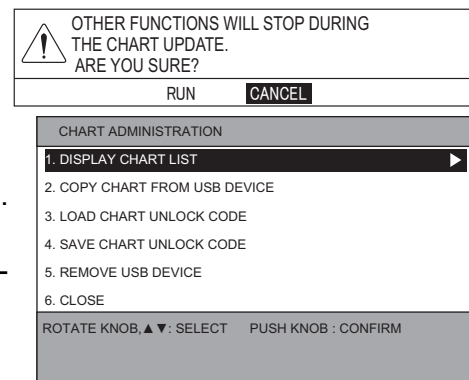

# APPENDIX 1 JIS CABLE GUIDE

Cables listed in the manual are usually shown as Japanese Industrial Standard (JIS). Use the following guide to locate an equivalent cable locally.

JIS cable names may have up to 6 alphabetical characters, followed by a dash and a numerical value (example: DPYC-2.5).

For core types D and T, the numerical designation indicates the *cross-sectional Area (mm<sup>2</sup>)* of the core wire(s) in the cable.

For core types M and TT, the numerical designation indicates the *number of core wires* in the cable.

## 1. Core Type

- D: Double core power line
- T: Triple core power line
- M: Multi core
- TT: Twisted pair communications (1Q=quad cable)

## 2. Insulation Type

- P: Ethylene Propylene Rubber

## 3. Sheath Type

- Y: PVC (Vinyl)

## 4. Armor Type

- C: Steel

## 5. Sheath Type

- Y: Anticorrosive vinyl sheath

## 6. Shielding Type

- S: All cores in one sheath
- S: Individually sheathed cores
- SLA: All cores in one shield, plastic tape w/aluminum tape
- SLA: Individually shielded cores, plastic tape w/aluminum tape



EX: <sup>1 2 3 4 5 6</sup> TTYCYSLA - 4  
Designation type      # of twisted pairs

EX: <sup>1 2 3 4</sup> MPYC - 4  
Designation type      # of cores

The following reference table lists gives the measurements of JIS cables commonly used with Furuno products:

Type	Area	Core Diameter	Cable Diameter	Type	Area	Core Diameter	Cable Diameter
DPYC-1.5	1.5mm <sup>2</sup>	1.56mm	11.7mm	TTYCS-1	0.75mm <sup>2</sup>	1.11mm	10.1mm
DPYC-2.5	2.5mm <sup>2</sup>	2.01mm	12.8mm	TTYCS-1T	0.75mm <sup>2</sup>	1.11mm	10.6mm
DPYC-4	4.0mm <sup>2</sup>	2.55mm	13.9mm	TTYCS-1Q	0.75mm <sup>2</sup>	1.11mm	11.3mm
DPYC-6	6.0mm <sup>2</sup>	3.12mm	15.2mm	TTYCS-4	0.75mm <sup>2</sup>	1.11mm	16.3mm
DPYC-10	10.0mm <sup>2</sup>	4.05mm	17.1mm	TTYCSLA-1	0.75mm <sup>2</sup>	1.11mm	9.4mm
DPYCY-1.5	1.5mm <sup>2</sup>	1.56mm	13.7mm	TTYCSLA-1T	0.75mm <sup>2</sup>	1.11mm	10.1mm
DPYCY-2.5	2.5mm <sup>2</sup>	2.01mm	14.8mm	TTYCSLA-1Q	0.75mm <sup>2</sup>	1.11mm	10.8mm
DPYCY-4	4.0mm <sup>2</sup>	2.55mm	15.9mm	TTYCSLA-4	0.75mm <sup>2</sup>	1.11mm	15.7mm
MPYC-2	1.0mm <sup>2</sup>	1.29mm	10.0mm	TTYCY-1	0.75mm <sup>2</sup>	1.11mm	11.0mm
MPYC-4	1.0mm <sup>2</sup>	1.29mm	11.2mm	TTYCY-1T	0.75mm <sup>2</sup>	1.11mm	11.7mm
MPYCSLA-4	1.0mm <sup>2</sup>	1.29mm	11.4mm	TTYCY-1Q	0.75mm <sup>2</sup>	1.11mm	12.6mm
MPYC-7	1.0mm <sup>2</sup>	1.29mm	13.2mm	TTYCY-4	0.75mm <sup>2</sup>	1.11mm	17.7mm
MPYC-12	1.0mm <sup>2</sup>	1.29mm	16.8mm	TTYCY-4S	0.75mm <sup>2</sup>	1.11mm	21.1mm
TPYC-1.5	1.5mm <sup>2</sup>	1.56mm	12.5mm	TTYCY-4SLA	0.75mm <sup>2</sup>	1.11mm	19.5mm
TPYC-2.5	2.5mm <sup>2</sup>	2.01mm	13.5mm	TTYCYS-1	0.75mm <sup>2</sup>	1.11mm	12.1mm
TPYC-4	4.0mm <sup>2</sup>	2.55mm	14.7mm	TTYCYS-4	0.75mm <sup>2</sup>	1.11mm	18.5mm
TPYCY-1.5	1.5mm <sup>2</sup>	1.56mm	14.5mm	TTYCYSLA-1	0.75mm <sup>2</sup>	1.11mm	11.2mm
TPYCY-2.5	2.5mm <sup>2</sup>	2.01mm	15.5mm	TTYCYSLA-4	0.75mm <sup>2</sup>	1.11mm	17.9mm
TPYCY-4	4.0mm <sup>2</sup>	2.55mm	16.9mm				

PACKING LIST GP-3700\*-1N/HK, GP-3700F\*-1N/HK

14DA-X-9852-6 1/1

A-2

NAME	OUTLINE	DESCRIPTION/CODE No.	Q' TY
<b>ユニット UNIT</b>			
空中線部 ANTENNA UNIT		GPA-C01S 000-038-269-00	1
指示器 DISPLAY UNIT		GP-3700* 000-035-326-00 **	1
<b>予備品 SPARE PARTS</b>			
予備品 SPARE PARTS		SP14-03601 001-303-400-00 **	1
<b>付属品 ACCESSORIES</b>			
フィルタークリーナー LCD CLEANING CLOTH		19-028-3125-7 100-360-677-10	1
<b>工事材料 INSTALLATION MATERIALS</b>			
ケーブル組品 CABLE ASSEMBLY		TNC-PS/PS-3D-L15M-R 001-173-110-10	1
ケーブル組品MJ CABLE ASSEMBLY		MJ-A3SPF0013-035C (5A) 000-157-939-10	1
工事材料 INSTALLATION MATERIALS		CP14-08201 001-516-710-00 **	1

1.コード番号末尾の[\*\*]は、選択品の代表コードを表します。  
1.CODE NUMBER ENDING WITH "\*\*" INDICATES THE CODE NUMBER OF REPRESENTATIVE MATERIAL.  
2.(\*)の書類は、GP-3700用です。  
2.(\*) MARKED DOCUMENTS ARE FOR GP-3700.

(略図の寸法は、参考値です。DIMENSIONS IN DRAWING FOR REFERENCE ONLY.)

NAME	OUTLINE	DESCRIPTION/CODE No.	Q' TY
<b>図書 DOCUMENT</b>			
フラッシュマウント型紙 FLUSH MOUNTING TEMPLATE		C42-01505-* 000-191-168-1*	1
取扱説明書 OPERATOR'S MANUAL		OM*-44910-* 000-191-154-1* **	1 (*1)
取扱説明書 OPERATOR'S MANUAL		OM*-44920-* 000-191-161-1* **	1 (*2)
操作要領書 OPERATOR'S GUIDE		OS*-44910-* 000-191-156-1* **	1 (*1)
操作要領書 OPERATOR'S GUIDE		OS*-44920-* 000-191-163-1* **	1 (*2)
装備要領書 INSTALLATION MANUAL		IM*-44910-* 000-191-158-1* **	1 (*1)
装備要領書 INSTALLATION MANUAL		IM*-44920-* 000-191-165-1* **	1 (*2)

3.(\*)の書類は、GP-3700F用です。  
3.(\*) MARKED DOCUMENTS ARE FOR GP-3700F.

C4491-Z02-G

PACKING LIST GP-3700\*-1A/HK, GP-3700F\*-1A/HK

14DA-X-9851-6 1/1

A-1

NAME	OUTLINE	DESCRIPTION/CODE No.	Q' TY
<b>ユニット UNIT</b>			
空中線部 ANTENNA UNIT		GPA-C01S 000-038-269-00	1
指示器 DISPLAY UNIT		GP-3700* 000-035-326-00 **	1
<b>予備品 SPARE PARTS</b>			
予備品 SPARE PARTS		SP14-03601 001-303-400-00 **	1
<b>付属品 ACCESSORIES</b>			
フィルタークリーナー LCD CLEANING CLOTH		19-028-3125-7 100-360-677-10	1
<b>工事材料 INSTALLATION MATERIALS</b>			
ケーブル組品 CABLE ASSEMBLY		TNC-PS/PS-3D-L15M-R 001-173-110-10	1
ケーブル組品MJ CABLE ASSEMBLY		MJ-A3SPF0013-035C (5A) 000-157-939-10	1
マスト取付金具 MAST MOUNTING KIT		CP20-01111 001-134-610-00 **	1

1.コード番号末尾の[\*\*]は、選択品の代表コードを表します。  
1.CODE NUMBER ENDING WITH "\*\*" INDICATES THE CODE NUMBER OF REPRESENTATIVE MATERIAL.  
2.(\*)の書類は、GP-3700用です。  
2.(\*) MARKED DOCUMENTS ARE FOR GP-3700.

(略図の寸法は、参考値です。DIMENSIONS IN DRAWING FOR REFERENCE ONLY.)

NAME	OUTLINE	DESCRIPTION/CODE No.	Q' TY
工事材料 INSTALLATION MATERIALS		CP14-08201 001-516-710-00 **	1
<b>図書 DOCUMENT</b>			
フラッシュマウント型紙 FLUSH MOUNTING TEMPLATE		C42-01505-* 000-191-168-1*	1
取扱説明書 OPERATOR'S MANUAL		OM*-44910-* 000-191-154-1* **	1 (*1)
取扱説明書 OPERATOR'S MANUAL		OM*-44920-* 000-191-161-1* **	1 (*2)
操作要領書 OPERATOR'S GUIDE		OS*-44910-* 000-191-156-1* **	1 (*1)
操作要領書 OPERATOR'S GUIDE		OS*-44920-* 000-191-163-1* **	1 (*2)
装備要領書 INSTALLATION MANUAL		IM*-44910-* 000-191-158-1* **	1 (*1)
装備要領書 INSTALLATION MANUAL		IM*-44920-* 000-191-165-1* **	1 (*2)

3.(\*)の書類は、GP-3700F用です。  
3.(\*) MARKED DOCUMENTS ARE FOR GP-3700F.

C4491-Z01-G

# PACKING LIST GP-3700-\*-2NB/HK ,GP-3700F-\*-2NB/HK

14DA-X-9854 -5 1/1

A-4

NAME	OUTLINE	DESCRIPTION/CODE	Q'TY
<b>ユニット UNIT</b>			
空中線部 ANTENNA ASSEMBLY		GPA-021S 000-026-989-00	1
指示器 DISPLAY UNIT		GP-3700* 000-035-326-00 **	1
<b>予備品 SPARE PARTS</b>			
予備品 SPARE PARTS		SP14-03601 001-303-400-00 **	1
<b>付属品 ACCESSORIES</b>			
フィルタークリーナー LCD CLEANING CLOTH		19-028-3125-7 100-360-677-10	1
<b>工事材料 INSTALLATION MATERIALS</b>			
ケーブル組品 CABLE ASSEMBLY		TNC-PS/PS-3D-L15M-R 001-173-110-10	1
ケーブル組品MJ CABLE ASSEMBLY		MJ-A3SPF0013-035C(5A) 000-157-939-10	1
工事材料 INSTALLATION MATERIALS		CP14-08201 001-516-710-00 **	1

1.コード番号末尾の[\*]は、選択品の代表コードを表します。  
1 CODE NUMBER ENDING WITH "\*" INDICATES THE CODE NUMBER OF REPRESENTATIVE MATERIAL.

2.(\*1)の書類は、GP-3700用です。  
2.(\*1) MARKED DOCUMENTS ARE FOR GP-3700.

略図の寸法は、参考値です。DIMENSIONS IN DRAWING FOR REFERENCE ONLY.)

NAME	OUTLINE	DESCRIPTION/CODE	Q'TY
<b>図書 DOCUMENT</b>			
フラッシュマウント型紙 FLUSH MOUNTING TEMPLATE		C42-01505-* 000-191-168-1*	1
取扱説明書 OPERATOR'S MANUAL		OM*-44910-* 000-191-154-1* **	1 (*1)
取扱説明書 OPERATOR'S MANUAL		OM*-44920-* 000-191-161-1* **	1 (*2)
操作要領書 OPERATOR'S GUIDE		OS*-44910-* 000-191-156-1* **	1 (*1)
操作要領書 OPERATOR'S GUIDE		OS*-44920-* 000-191-163-1* **	1 (*2)
装備要領書 INSTALLATION MANUAL		IM*-44910-* 000-191-158-1* **	1 (*1)
装備要領書 INSTALLATION MANUAL		IM*-44920-* 000-191-165-1* **	1 (*2)

3.(\*2)の書類は、GP-3700F用です。  
3.(\*2) MARKED DOCUMENTS ARE FOR GP-3700F.

C4491-Z04-F

# PACKING LIST GP-3700-\*-2AB/HK ,GP-3700F-\*-2AB/HK

14DA-X-9853 -5 1/1

A-3

NAME	OUTLINE	DESCRIPTION/CODE	Q'TY
<b>ユニット UNIT</b>			
空中線部 ANTENNA ASSEMBLY		GPA-021S 000-026-989-00	1
指示器 DISPLAY UNIT		GP-3700* 000-035-326-00 **	1
<b>予備品 SPARE PARTS</b>			
予備品 SPARE PARTS		SP14-03601 001-303-400-00 **	1
<b>付属品 ACCESSORIES</b>			
フィルタークリーナー LCD CLEANING CLOTH		19-028-3125-7 100-360-677-10	1
<b>工事材料 INSTALLATION MATERIALS</b>			
ケーブル組品 CABLE ASSEMBLY		TNC-PS/PS-3D-L15M-R 001-173-110-10	1
ケーブル組品MJ CABLE ASSEMBLY		MJ-A3SPF0013-035C(5A) 000-157-939-10	1
マスト取付金具 MAST MOUNTING KIT		CP20-01111 001-134-610-00 **	1

1.コード番号末尾の[\*]は、選択品の代表コードを表します。  
1 CODE NUMBER ENDING WITH "\*" INDICATES THE CODE NUMBER OF REPRESENTATIVE MATERIAL.

2.(\*1)の書類は、GP-3700用です。  
2.(\*1) MARKED DOCUMENTS ARE FOR GP-3700.

略図の寸法は、参考値です。DIMENSIONS IN DRAWING FOR REFERENCE ONLY.)



NAME	OUTLINE	DESCRIPTION/CODE	Q'TY
<b>工事材料 INSTALLATION MATERIALS</b>		CP14-08201 001-516-710-00 **	1
<b>図書 DOCUMENT</b>			
フラッシュマウント型紙 FLUSH MOUNTING TEMPLATE		C42-01505-* 000-191-168-1*	1
取扱説明書 OPERATOR'S MANUAL		OM*-44910-* 000-191-154-1* **	1 (*1)
取扱説明書 OPERATOR'S MANUAL		OM*-44920-* 000-191-161-1* **	1 (*2)
操作要領書 OPERATOR'S GUIDE		OS*-44910-* 000-191-156-1* **	1 (*1)
操作要領書 OPERATOR'S GUIDE		OS*-44920-* 000-191-163-1* **	1 (*2)
装備要領書 INSTALLATION MANUAL		IM*-44910-* 000-191-158-1* **	1 (*1)
装備要領書 INSTALLATION MANUAL		IM*-44920-* 000-191-165-1* **	1 (*2)

3.(\*2)の書類は、GP-3700F用です。  
3.(\*2) MARKED DOCUMENTS ARE FOR GP-3700F.

C4491-Z03-F



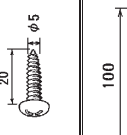



**FURUNO**



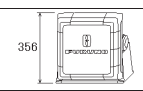

CODE NO.	001-430-020-00	14DA-X-9401-2	1/1	
TYPE	CP14-08201			
工事材料表 INSTALLATION MATERIALS	略図 OUTLINE	型名/規格 DESCRIPTIONS	数量 Q'TY	用途/備考 REMARKS
1		5X20 SDS304 SELF-TAPPING SCREW φ5	6	
2		100 TIEING WIRE BAND	3	

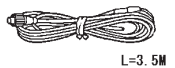
(略図の寸法は、参考値です。 DIMENSIONS IN DRAWING FOR REFERENCE ONLY.)  
FURUNO ELECTRIC CO., LTD.  
C4491-M01-C

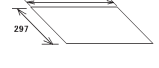
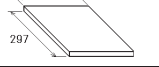
**PACKING LIST** GP-3700-\*-ON/HK ,GP-3700F-\*-ON/HK

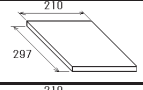
14DA-X-9855-5 1/1

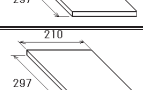
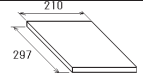
NAME	OUTLINE	DESCRIPTION/ CODE	Q'TY
<b>ユニット</b> UNIT			
指示器 DISPLAY UNIT		GP-3700* 000-035-326-00 **	1
<b>予備品</b> SPARE PARTS			
予備品 SPARE PARTS		SP14-03601 001-303-400-00 **	1
<b>付属品</b> ACCESSORIES			
フィルタークリーナー LCD CLEANING CLOTH		19-028-3125-7 100-360-677-10	1
<b>工事材料</b> INSTALLATION MATERIALS			
ケーブル組品MJ CABLE ASSEMBLY		MJ-A3SPF0013-035C(5A) 000-157-939-10	1
工事材料 INSTALLATION MATERIALS		CP14-08201 001-516-710-00 **	1
<b>図書</b> DOCUMENT			
フラッシュマウント型紙 FLUSH MOUNTING TEMPLATE		C42-01505-* 000-191-168-1*	1
取扱説明書 OPERATOR'S MANUAL		OM*-44910-* 000-191-154-1* **	1 (*1)

NAME	OUTLINE	DESCRIPTION/ CODE	Q'TY
取扱説明書 OPERATOR'S MANUAL		OM*-44920-* 000-191-161-1* **	1 (*2)
操作要領書 OPERATOR'S GUIDE		OS*-44910-* 000-191-156-1* **	1 (*1)
操作要領書 OPERATOR'S GUIDE		OS*-44920-* 000-191-163-1* **	1 (*2)
装備要領書 INSTALLATION MANUAL		IM*-44910-* 000-191-158-1* **	1 (*1)
装備要領書 INSTALLATION MANUAL		IM*-44920-* 000-191-165-1* **	1 (*2)

1.コード番号末尾の[\*]は、選択品の代表コードを表します。  
1. CODE NUMBER ENDING WITH "\*" INDICATES THE CODE NUMBER OF REPRESENTATIVE MATERIAL.

2.(\*1)の書類は、GP-3700用です。  
2.(\*1) MARKED DOCUMENTS ARE FOR GP-3700.

(略図の寸法は、参考値です。 DIMENSIONS IN DRAWING FOR REFERENCE ONLY.)

3.(\*2)の書類は、GP-3700F用です。  
3.(\*2) MARKED DOCUMENTS ARE FOR GP-3700F.

**FURUNO**

CODE NO.	001-516-710-00	14DA-X-9403-0	1/1
TYPE	CP14-08201		

**工事材料表**

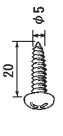
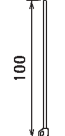
番号 NO.	名称 NAME	略図 OUTLINE	型名/規格 DESCRIPTIONS	数量 QTY	用途/備考 REMARKS
1	セルフタッピングネジ 1/2 SELF-TAPPING SCREW		5X20 SUS304 CODE NO. 000-162-608-10	6	
2	ワイヤバンド TIEING WIRE BAND		AB100-S CODE NO. 000-191-622-10	3	

(略図の寸法は、参考値です。 DIMENSIONS IN DRAWING FOR REFERENCE ONLY.)

FURUNO ELECTRIC CO., LTD.

CN

C4491-M03-A

**FURUNO**

CODE NO.	004-365-780-00	14BN-X-9403-7	1/1
TYPE	CP20-01111		

**工事材料表**

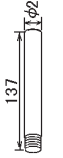
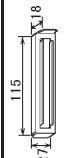
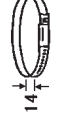
番号 NO.	名称 NAME	略図 OUTLINE	型名/規格 DESCRIPTIONS	数量 QTY	用途/備考 REMARKS
1	パイプ PIPE		20-007-3011-4 CODE NO. 100-163-264-10	1	
2	取付補助金具 INSTALLING SPACER		20-007-3012-1 R0MS CODE NO. 100-163-271-10	1	
3	ホースクランプ HOSE CLAMP		NO. 6348 CODE NO. 000-166-005-10	2	



型式/コード番号が異なる図の場合、下段より上段に代わる標準部品であり、どちらかが入っています。なお、品質は変わりません。  
TWO TYPES AND CODES MAY BE LISTED FOR AN ITEM. THE LOWER PRODUCT MAY BE SHIPPED IN PLACE OF THE UPPER PRODUCT.  
QUALITY IS THE SAME.  
(略図の寸法は、参考値です。 DIMENSIONS IN DRAWING FOR REFERENCE ONLY.)

FURUNO ELECTRIC CO., LTD.

C3446-M01-J

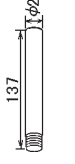
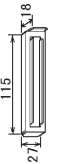

CODE NO.	001-134-610-00	14DA-X-9402-0	1/1
TYPE	CP20-01111		

番号 NO.	名称 NAME	略図 OUTLINE	型名/規格 DESCRIPTIONS	数量 QTY	用途/備考 REMARKS
1	パイプ PIPE		20-007-3011-4 CODE NO. 100-183-264-10	1	
2	取付補助金具 INSTALLING SPACER		20-007-3012-1 R0HS CODE NO. 100-183-271-10	1	
3	ホースクランプ HOSE CLAMP		NO. 6348 CODE NO. 000-166-005-10	2	

工事材料表

INSTALLATION MATERIALS

(略図の寸法は、参考値です。 DIMENSIONS IN DRAWING FOR REFERENCE ONLY.)

FURUNO ELECTRIC CO., LTD.

ON

C4491-M02-A



CODE NO.	001-246-900-00	14CZ-X-9301-0	1/1
TYPE	SPT14-03601	BOX NO.	P

SHIP NO.	SPARE PARTS LIST FOR	U S E	DNG. NO. OR TYPE NO.	OUTLINE	ITEM NO.	NAME OF PART	QUANTITY		REMARKS/CODE NO.
							WORKING PER SET	SPARE PER VESSEL	
			FG80-A 125V 5A PBF		1	グラス FUSE	1	2	000-155-853-10

MFR'S NAME	FURUNO ELECTRIC CO., LTD.	DWG NO.	C4493-P01-A	1/1
------------	---------------------------	---------	-------------	-----

(略図の寸法は、参考値です。 DIMENSIONS IN DRAWING FOR REFERENCE ONLY.)  
 型式/コード番号が2枚の場合、下段より上段に代わる油断品であり、どちらかが入っています。なお、品質は変わりません。  
 TWO TYPES AND CODES MAY BE LISTED FOR AN ITEM. THE LOWER PRODUCT MAY BE SHIPPED IN PLACE OF THE UPPER PRODUCT. QUALITY IS THE SAME.

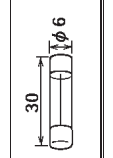

SHIP NO.		SPARE PARTS LIST FOR		U S E			REMARKS/CODE NO.	
CODE NO.	TYPE	001-303-400-00	SPI4-03601	14CZ-X-9303-1	BOX NO.	SETS PER VESSEL		
ITEM NO.	NAME OF PART	OUTLINE	DWG. NO. OR TYPE NO.	QUANTITY				
				WORKING	SPARE			
				PER SET	PER VES			
1	GLASS TUBE FUSE		FG80-A 125V 5A PBF	1	2		000-155-853-10	
MFR'S NAME	FURUNO ELECTRIC CO., LTD.					DWG NO.	C4483-P03-B CN	1/1

(略図の寸法は、参考値です。 DIMENSIONS IN DRAWING FOR REFERENCE ONLY.)



表1 TABLE 1

寸法区分 (mm) DIMENSION	公差 (mm) TOLERANCE
0 < L ≤ 50	±1.5
50 < L ≤ 100	±2.5
100 < L ≤ 500	±3

表2 TABLE 2

型式 MODEL	質量 (kg±10%) MASS
GP-3700	4.6
GP-3700F	4.8

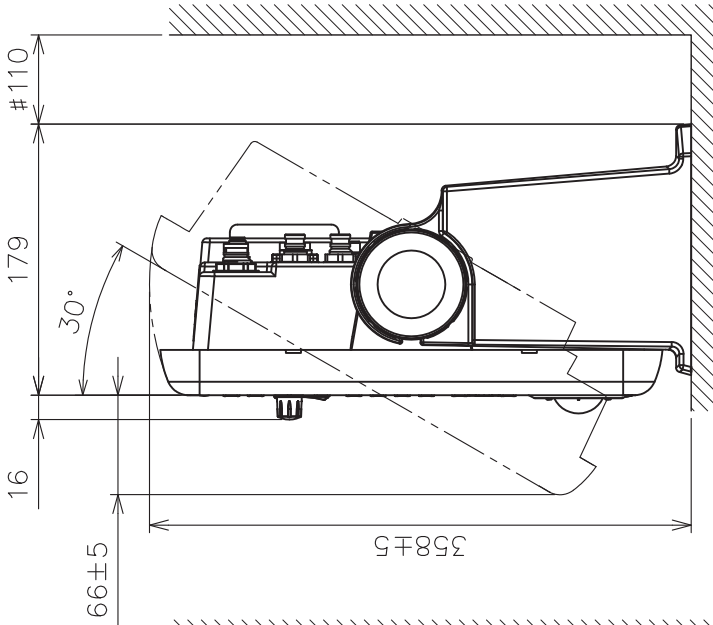
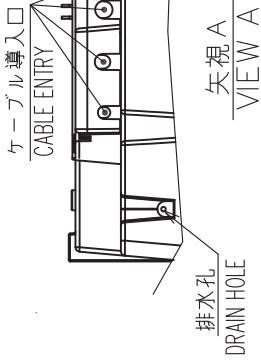
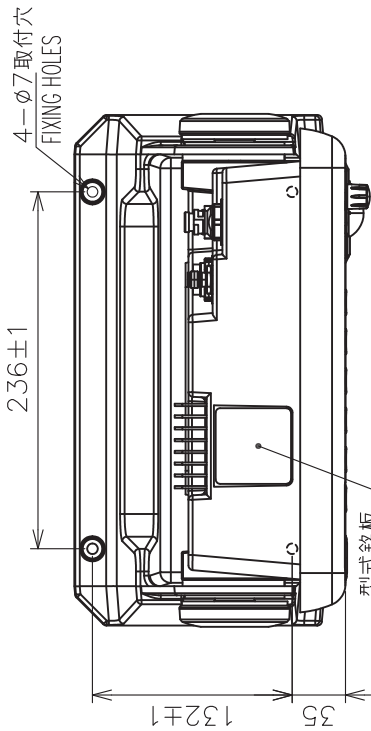
- 注記 1) 指定なき寸法公差は表1による。  
 2) #印寸法は最小サービスマン空間寸法とする。  
 3) 取付用ネジは+トラスタツピンネジ呼び径5×2.0を使用のこと。
- NOTE 1. TABLE 1 INDICATES TOLERANCE OF DIMENSIONS WHICH IS NOT SPECIFIED.  
 2. #: MINIMUM SERVICE CLEARANCE  
 3. USE TAPPING SCREWS  $\phi 5 \times 2.0$  FOR FIXING THE UNIT.

DRAWN	1/Apr/2016	A. MURAO	TITLE	GP-3700/3700F
CHECKED	/Apr/2016	T. YAMASAKI	名称	指示器 (卓上装備)
APPROVED	/Apr/2016	H. MAKI	外寸図	
SCALE	1/5	IMASS 表2参照 SEE TABLE 2	NAME	DISPLAY UNIT (TABLETOP MOUNT)
DWG.No.	C4491-G01-B	REF.No.	14-083-100G-3	OUTLINE DRAWING



表1 TABLE 1

寸法区分 (mm) DIMENSION	公差 (mm) TOLERANCE
0 < L ≤ 50	±1.5
50 < L ≤ 100	±2.5
100 < L ≤ 500	±3

表2 TABLE 2

型式 MODEL	質量 (kg±10%) MASS
GP-3700	4.5
GP-3700F	4.7

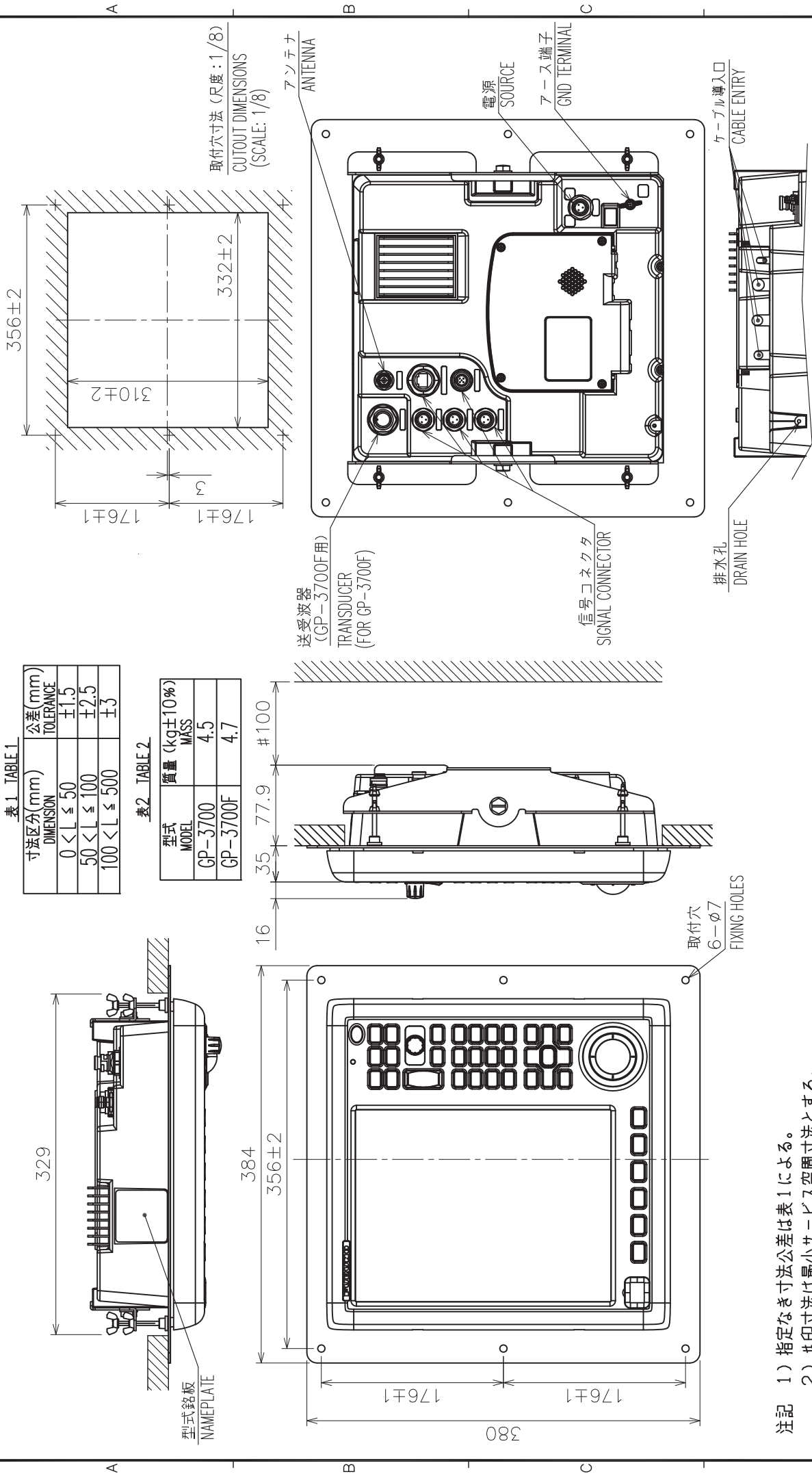
DRAWN	1/Apr/2016	A. MURAO	TITLE	GP-3700/3700F
CHECKED	1/Apr/2016	T. YAMASAKI	名称	指示器 (埋込装備)
APPROVED	4/Apr/2016	H. MAKI	外寸図	
SCALE	1/5	MASS 表参照 SEE TABLE 2	NAME	DISPLAY UNIT (FLUSH MOUNT)
DWG.No.	C4491-G02-B	REF.No.	14-083-110G-3	OUTLINE DRAWING

注記 1) 指定なき寸法公差は表1による。  
 2) #印寸法は最小サービス空間寸法とする。  
 3) 取付用ネジは+トラスタッピンネジ呼び径5×20を使用のこと。

NOTE 1. TABLE 1 INDICATES TOLERANCE OF DIMENSIONS WHICH IS NOT SPECIFIED.  
 2. #: MINIMUM SERVICE CLEARANCE  
 3. USE TAPPING SCREWS φ5x20 FOR FIXING THE UNIT.

**取付位置**  
MOUNTING LOCATION

他の機器のアンテナから下の図の距離以上離す。  
THIS FIGURE SHOWS THE SEPARATION DISTANCES FROM OTHER ANTENNAS TO AVOID MUTUAL INTERFERENCE.

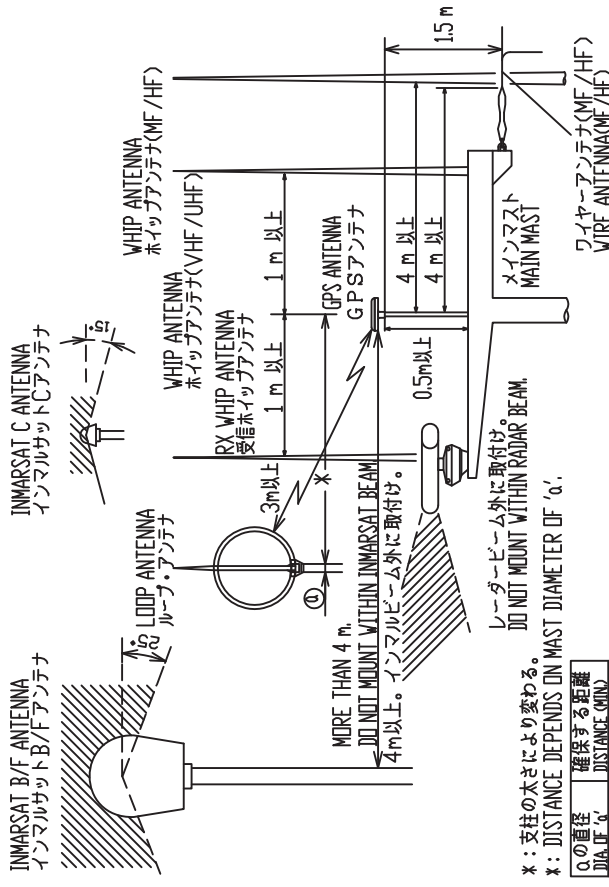

**B) スタンションやパルピットにつけるとき**

レール用アンテナベース No.13-RC5160  
(取付可能レール直径:φ19~φ32)  
(コード番号:000-806-114)

**HANDRAIL MOUNTING**

USE HANDRAIL MOUNTING BASE No.13-RC5160  
(CODE No.000-806-114, OPTION).  
THE DIAMETER OF THE HANDRAIL MAY BE  
FROM φ19mm TO φ32mm.

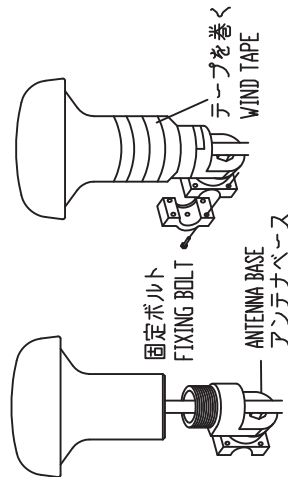

- 注記 1) パイプやアンテナベースはアンテナユニットにねじ込んだ後に固定する。  
2) アンテナを固定するときはパイプ(アンテナベース)をアンテナにねじ込むこと。  
アンテナ軸をねじるとコネクタ部やケーブルに無理がかかり、故障の原因となる。
- NOTE 1. FASTEN PIPE(ANTENNA BASE) TO ANTENNA UNIT FIRST THEN FIX THEM TO MAST OR HANDRAIL.  
2. WHEN FIXING ANTENNA, TURN PIPE OR ANTENNA BASE; NOT THE ANTENNA.  
TURNING THE ANTENNA MAY TWIST THE CABLE AND PLACE STRESS ON CONNECTOR.

**A) マストへの取付け**  
MAST MOUNTING

α) マスト取付金具CP20-0111(工事材料)でマストに固定する。  
USE MAST MOUNTING KIT CP20-0111.

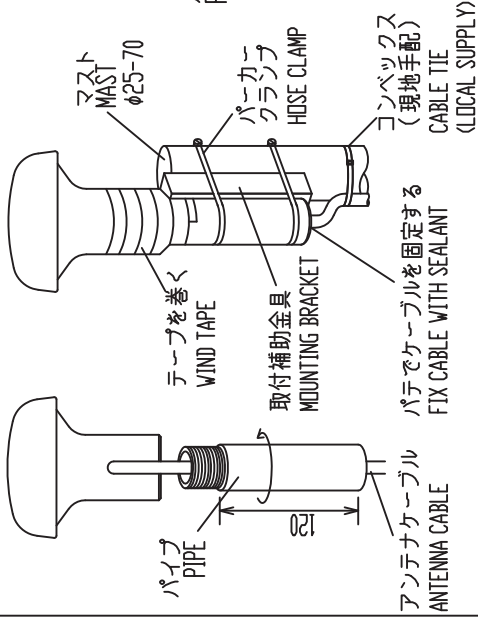

β) パイプのみを使うとき  
USE A PIPE ONLY.

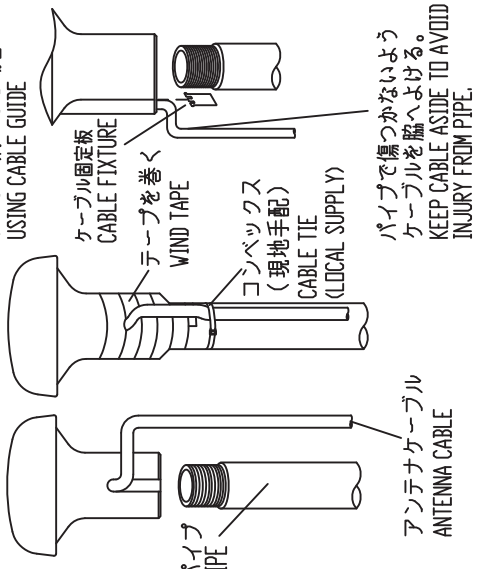

ケーブル溝のある場合  
USING CABLE GUIDE

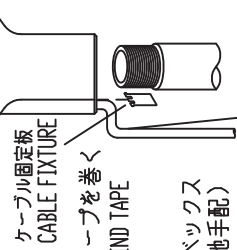

パイプで傷つかないよう  
ケーブルを脇へよける。  
KEEP CABLE ASIDE TO AVOID  
INJURY FROM PIPE.

**C) 取付ける場所が傾斜しているとき** ANTENNA BASE MOUNTING

オプションのアンテナベースを使う。  
USE OPTIONAL ANTENNA BASE.

アンテナベース基部  
MOUNTING DIMENSIONS OF ANTENNA BASE.

傾斜 INCLINATION	5° - 33°	32° - 65°	65° - 98°
取付方法 MOUNTING METHOD			
アンテナベース型式 ANT. BASE TYPE	直型アンテナベース RIGHT ANGLE ANTENNA BASE No.13-QA330	L型アンテナベース L-TYPE ANTENNA BASE No.13-QA310	L型アンテナベース L-TYPE ANTENNA BASE No.13-QA310
コード番号 CODE No.	000-803-239	000-803-240	000-803-240

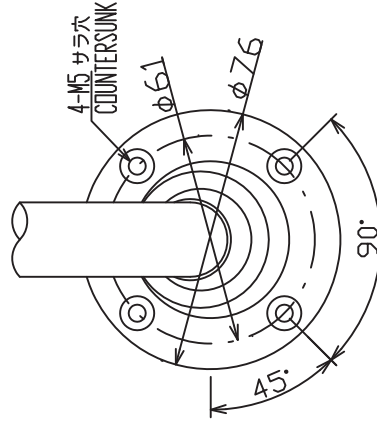

DRAWN 14/MAY/2014 T.YAMASAKI  
CHECKED 14/MAY/2014 H.MAKI  
APPROVED 15/May/2014 H.MAKI  
SCALE MASS  
Drawing No. C4384-Y01-F

TITLE GPA series  
名称 空中線部  
装備要領図  
NAME ANTENNA UNIT  
INSTALLATION PROCEDURE

A

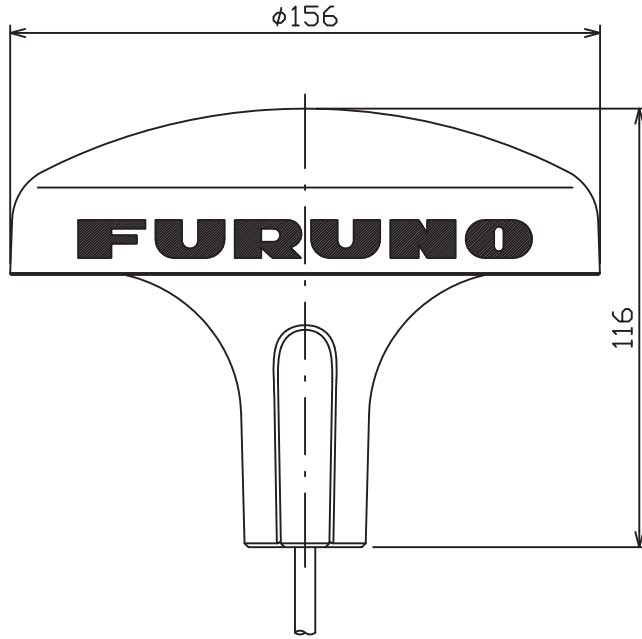

B

1-14UNS1B

ねじ山数(25.4mmにつき): 14  
 ピッチ: 1.8143 mm  
 オネジ有効長さ: 15.17 mm  
 オネジ有効径: 24.17 mm

THREAD PER 25.4mm (1 INCH): 14  
 PITCH: 1.8143 mm  
 THREAD LENGTH: 15.17 mm  
 PITCH DIAMETER: 24.17 mm

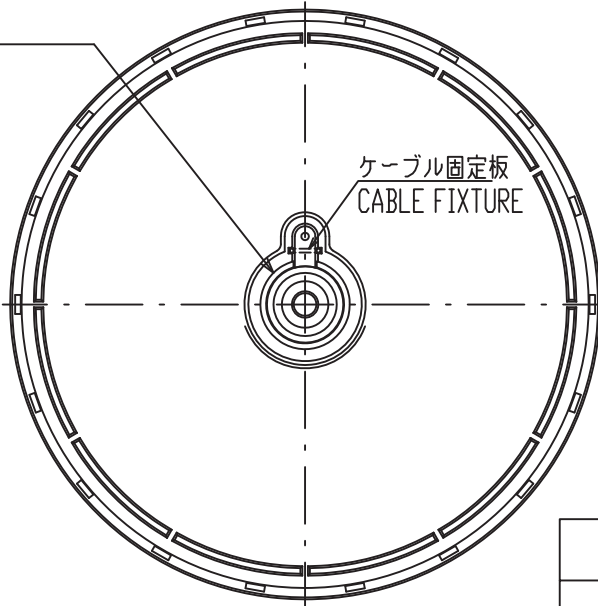

C

表1 TABLE 1

寸法区分(mm) DIMENSION	公差(mm) TOLERANCE
L ≤ 50	±1.5
50 < L ≤ 100	±2.5
100 < L ≤ 500	±3

表2 TABLE 2

型式 TYPE	ケーブル長(m) CABLE LENGTH	プラグ PLAG	質量 (kg±10%) MASS
GPA-019	10	TNC-P-3	0.98
GPA-019S	0.2	TNC-J-3	0.54
GPA-020S	0.2	TNC-J-3	0.32
GPA-021S	0.2	TNC-J-3	0.52

D

注記

1) 指定外の寸法公差は表1による。

NOTE

1. TABLE 1 INDICATES TOLERANCE OF DIMENSIONS WHICH IS NOT SPECIFIED.

DRAWN	14/May/2013 T.YAMASAKI	TITLE	GPA-019/019S/020S/021S
CHECKED	14/May/2013 H.MAKI	名称	空中線部
APPROVED	17/May/2013 H.MAKI		外寸図
SCALE	1/2 MASS TABLE 2 表2参照	NAME	ANTENNA UNIT
DWG. No.	C4400-G01-G	REF. No.	20-016-210G-4
		OUTLINE DRAWING	



表1 TABLE 1

寸法区分(mm) DIMENSION	公差(mm) TOLERANCE
0 < L ≤ 50	±1.5
50 < L ≤ 100	±2.5
100 < L ≤ 500	±3

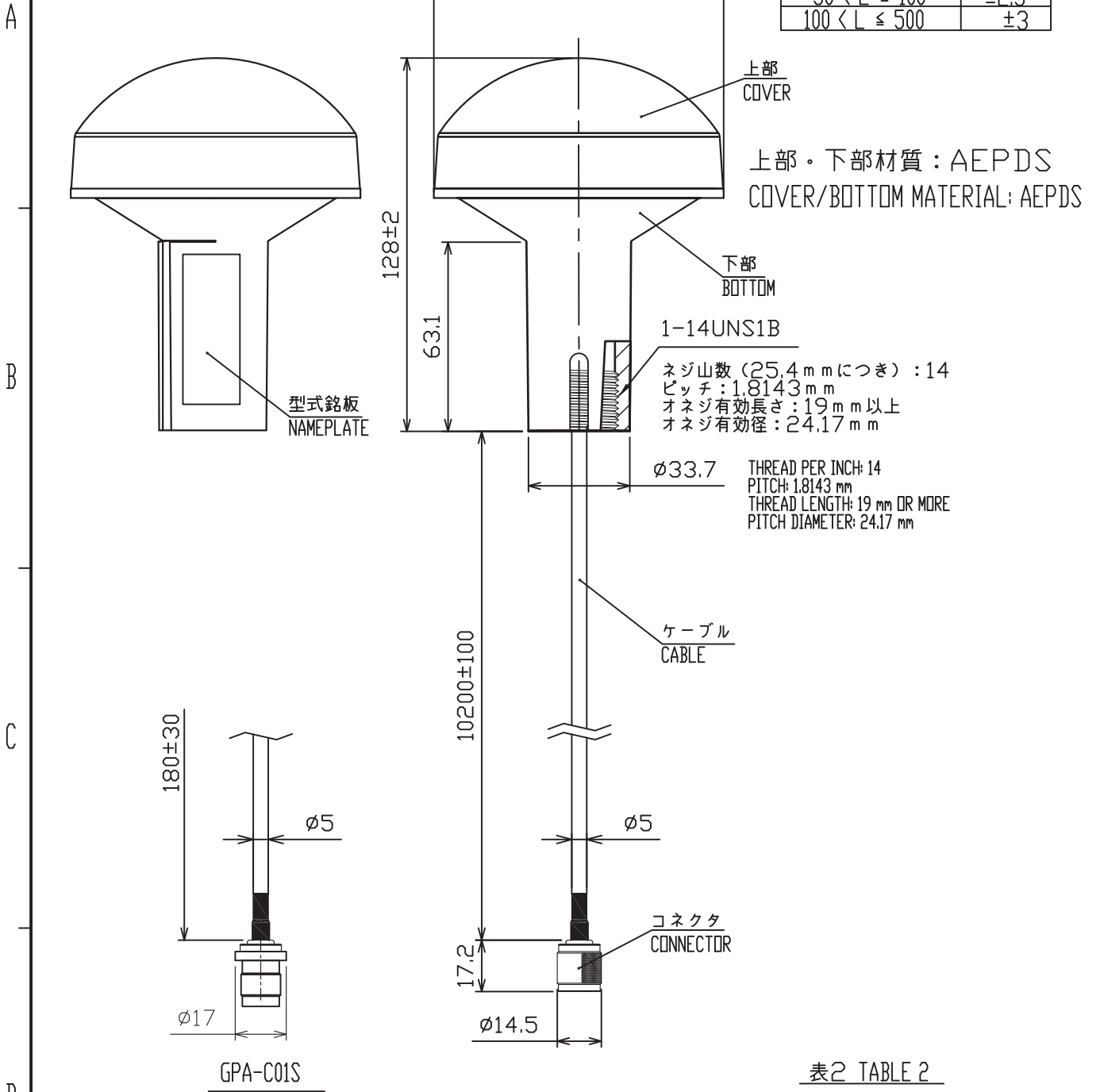

注記

1) 指定なき寸法公差は表1による。

NOTE

1. TABLE 1 INDICATES TOLERANCE OF DIMENSIONS WHICH IS NOT SPECIFIED.

型式 TYPE	ケーブル長 (m) CABLE LENGTH	プラグ PLUG	質量(kg±10%) MASS
GPA-C01	10.2	TNC-P-3	0.53
GPA-C01S	0.18	TNC-J-3	0.2

DRAWN 26/Jan/2021 T.YAMASAKI		TITLE GPA-C01/C01S
CHECKED 26/Jan/2021 H.MAKI		名称 空中線部
APPROVED 28/Jan/2021 H.MAKI	GP-39	外寸図
SCALE 1/2	MASS 表2参照 TABLE 2	質量はケーブルを含む。 MASS INCLUDES CABLE.
DWG. No. C4494-G04-C	REF. No.	NAME ANTENNA UNIT OUTLINE DRAWING

1 2 3 4 5



表1 TABLE 1

寸法区分 (mm) DIMENSION	公差 (mm) TOLERANCE
L ≤ 50	±1.5
50 < L ≤ 100	±2.5
100 < L ≤ 500	±3

- 注記
- 1) 指定外の寸法公差は表1による。
  - 2) #印寸法は最小サービス空間寸法とする。
  - 3) 取付ネジはトラスタックピピンネジ呼び径5×20を使用のこと。
- NOTE
1. TABLE 1 INDICATES TOLERANCE OF DIMENSIONS WHICH IS NOT SPECIFIED.
  2. #: MINIMUM SERVICE CLEARANCE.
  3. USE TAPPING SCREWS φ5x20 FOR FIXING THE UNIT.

DRAWN	6/Nov/2013	T. YAMASAKI	TITLE	RCU-030
CHECKED	6/Nov/2013	H. MAKI	名称	トラックボール操作部 (取付金具)
APPROVED	7/Nov/2013	H. MAKI	外寸図	
SCALE	1/2	質量 0.4 kg	NAME	TRACKBALL CONTROL UNIT (FIXTURE MOUNT)
DWG.No.	C4484-G01-A	質量は2mケーブルを含む。 REF.No. 24-016-110G-0		OUTLINE DRAWING

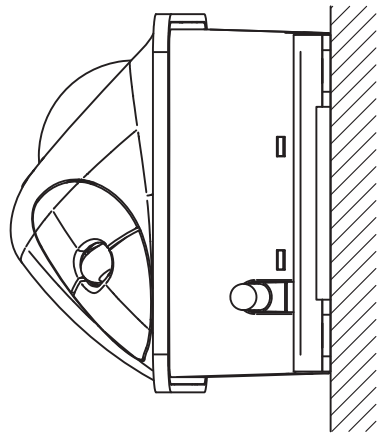
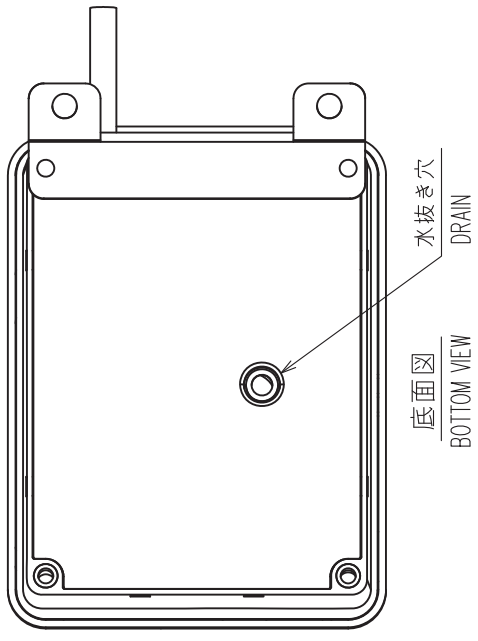
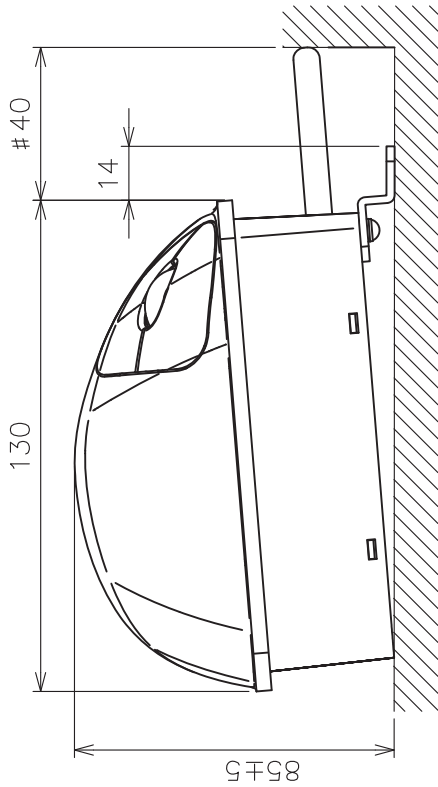
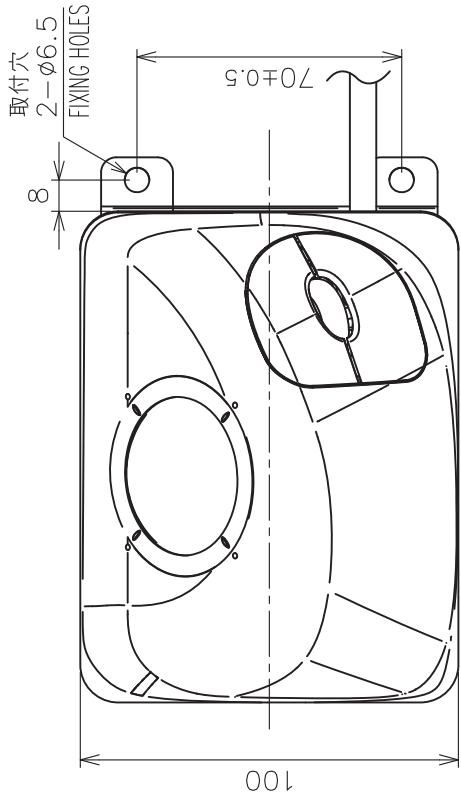

表1 TABLE 1

寸法区分 (mm) DIMENSION	公差 (mm) TOLERANCE
L ≤ 50	±1.5
50 < L ≤ 100	±2.5
100 < L ≤ 500	±3

DRAWN	6/Nov/2013	T. YAMASAKI	TITLE	RCU-030
CHECKED	6/Nov/2013	H. MAKI	名称	トラックボール操作部 (埋込装備)
APPROVED	7/Nov/2013	H. MAKI	外寸図	
SCALE	1/2	質量 0.5 kg #104質量はケーブルを含む。 #104 MASS INCLUDES 2m. CABLE.	NAME	TRACKBALL CONTROL UNIT (FLUSH MOUNT)
DWG.No.	C4484-G02-A	REF.No.	24-016-120G-0	OUTLINE DRAWING

- 注記 1) 指定外の寸法公差は表1による。  
 2) #印寸法は最小サービス空間寸法とする。
- NOTE 1. TABLE 1 INDICATES TOLERANCE OF DIMENSIONS WHICH IS NOT SPECIFIED.  
 2. # MINIMUM SERVICE CLEARANCE.

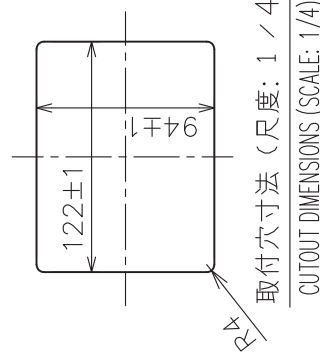
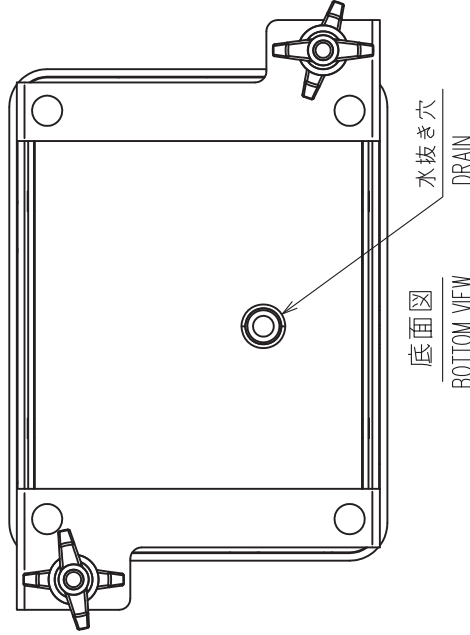
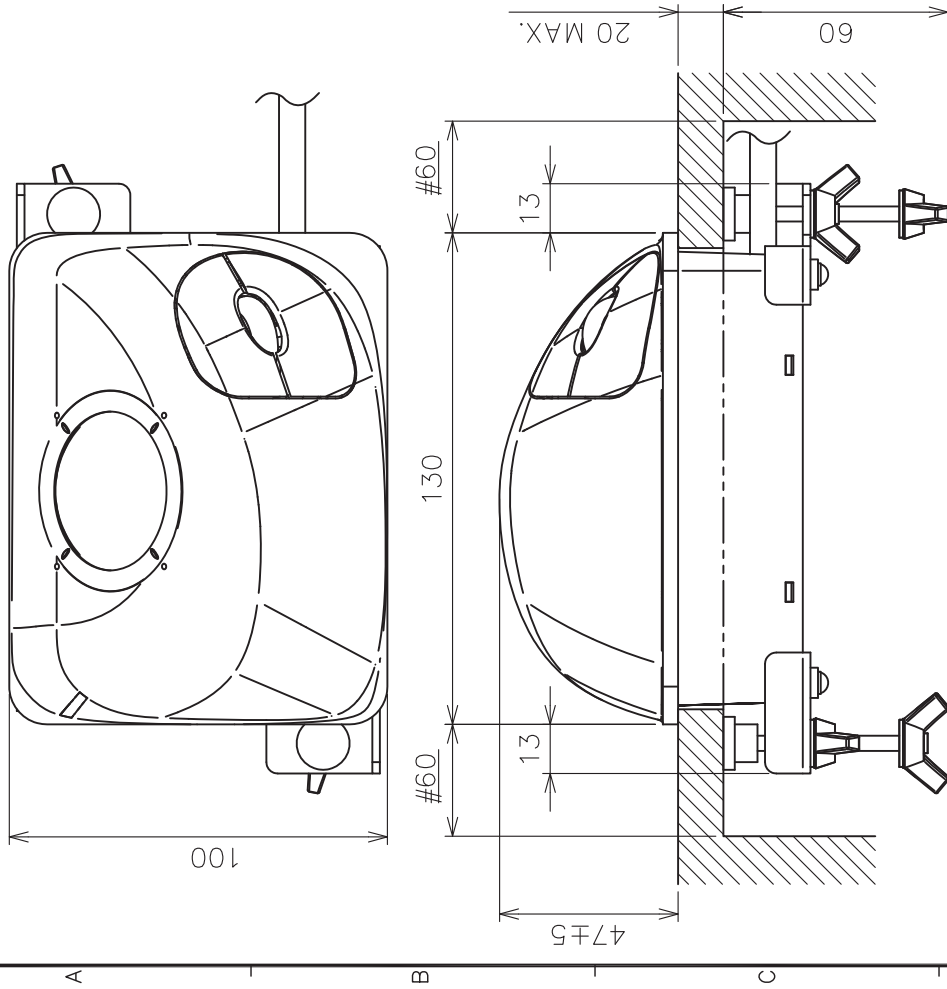
2 3 4

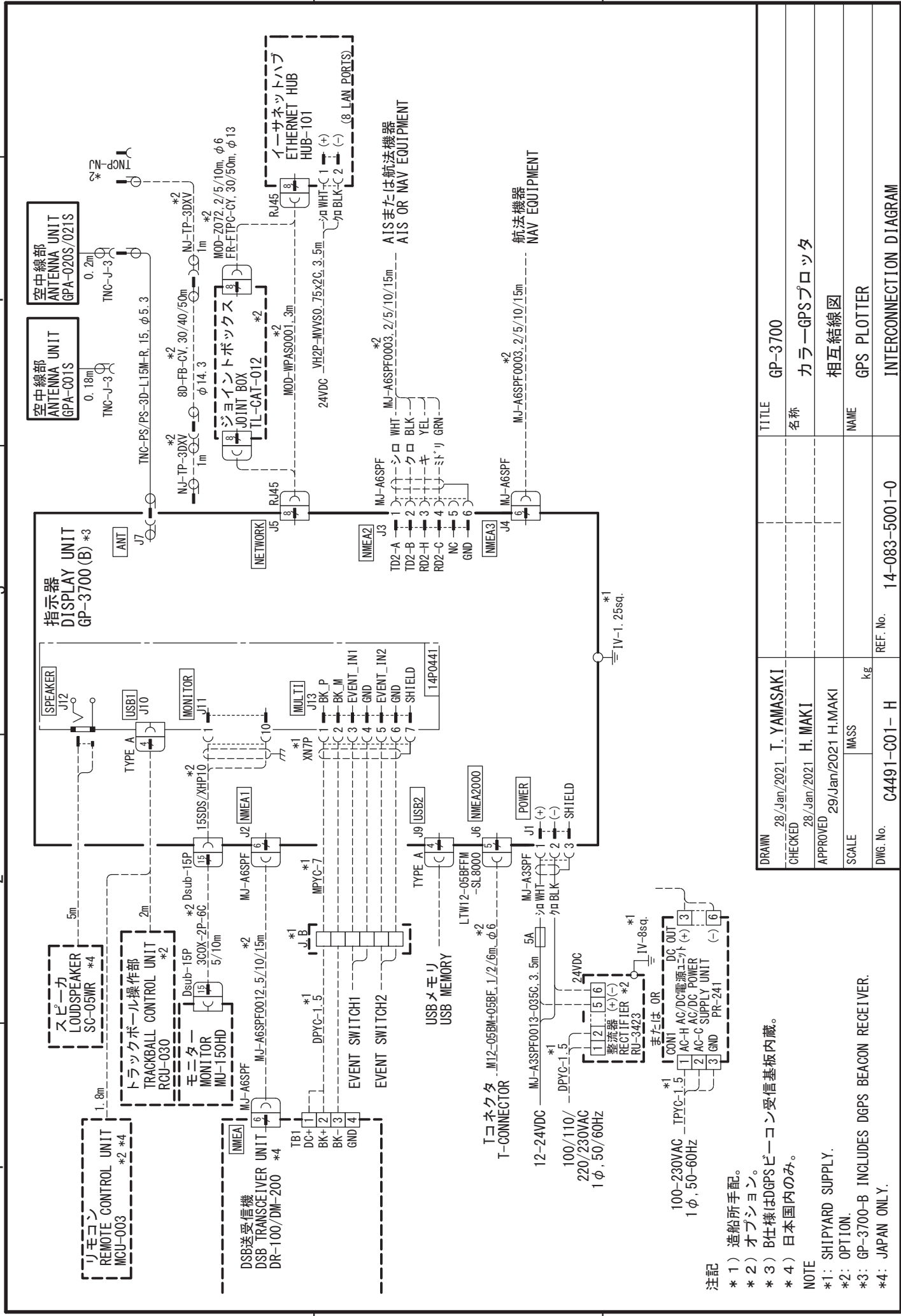

A

B

C

- 注記
- \* 1) 造船所手配。
  - \* 2) オプション。
  - \* 3) B仕様はGPSビーコン受信基板内蔵。
  - \* 4) 日本国内のみ。
- NOTE
- \* 1: SHIPYARD SUPPLY.
  - \* 2: OPTION.
  - \* 3: GP-3700-B INCLUDES DGPS BEACON RECEIVER.
  - \* 4: JAPAN ONLY.

DRAWN	28/Jan/2021	T. YAMASAKI	TITLE	GP-3700
CHECKED	28/Jan/2021	H. MAKI	名称	カラ-GPSプロッタ
APPROVED	29/Jan/2021	H. MAKI	相互結線図	
SCALE	MASS	kg	NAME	GPS PLOTTER
DWG. No.	C4491-C01-H	REF. No.	14-083-5001-0	INTERCONNECTION DIAGRAM







**ECF**

(Elemental Chlorine Free)

The paper used in this manual  
is elemental chlorine free.

**FURUNO ELECTRIC CO., LTD.**

9-52 Ashihara-cho,  
Nishinomiya, 662-8580, JAPAN

• FURUNO Authorized Distributor/Dealer

All rights reserved. Printed in Japan

Pub. No. IME-44910-E

(TEHI ) GP-3700

A : APR. 2017

E : FEB. 12, 2021



0 0 0 1 9 1 1 5 8 1 4