

FURUNO

OPERATOR'S MANUAL

INTEGRATED HEADING SENSOR

PG-500

FLUXGATE HEADING SENSOR

Model

C-500

IMPORTANT NOTICES

General

- This manual has been authored with simplified grammar, to meet the needs of international users.
- The operator of this equipment must read and follow the descriptions in this manual. Wrong operation or maintenance can void the warranty or cause injury.
- Do not copy any part of this manual without written permission from FURUNO.
- If this manual is lost or worn, contact your dealer about replacement.
- The contents of this manual and equipment specifications can change without notice.
- The example screens (or illustrations) shown in this manual can be different from the screens you see on your display. The screens you see depend on your system configuration and equipment settings.
- Save this manual for future reference.
- Any modification of the equipment (including software) by persons not authorized by FURUNO will void the warranty.
- The following concern acts as our importer in Europe, as defined in DECISION No 768/2008/EC.
 - Name: FURUNO EUROPE B.V.
 - Address: Ridderhaven 19B, 2984 BT Ridderkerk, The Netherlands
- The following concern acts as our importer in UK, as defined in SI 2016/1025 as amended SI 2019/470.
 - Name: FURUNO (UK) LTD.
 - Address: West Building Penner Road Havant Hampshire PO9 1QY, U.K.
- All brand, product names, trademarks, registered trademarks, and service marks belong to their respective holders.

How to discard this product

Discard this product according to local regulations for the disposal of industrial waste. For disposal in the USA, see the homepage of the Electronics Industries Alliance (<http://www.eiae.org/>) for the correct method of disposal.

How to discard a used battery

Some FURUNO products have a battery(ies). To see if your product has a battery, see the chapter on Maintenance. If a battery is used, tape the + and - terminals of the battery before disposal to prevent fire, heat generation caused by short circuit.

In the European Union

The crossed-out trash can symbol indicates that all types of batteries must not be discarded in standard trash, or at a trash site. Take the used batteries to a battery collection site according to your national legislation and the Batteries Directive 2006/66/EU.

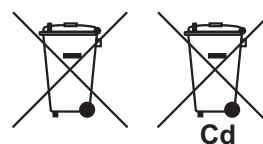

In the USA

The Mobius loop symbol (three chasing arrows) indicates that Ni-Cd and lead-acid rechargeable batteries must be recycled. Take the used batteries to a battery collection site according to local laws.

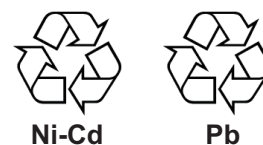

In the other countries

There are no international standards for the battery recycle symbol. The number of symbols can increase when the other countries make their own recycling symbols in the future.



SAFETY INSTRUCTIONS

Safety Information for the Installer



WARNING

Turn off the power at the mains switchboard before beginning the installation.
 Post a sign near the switch to indicate it should not be turned on while the equipment is being installed.

Fire or electrical shock can result if the power is left on or is applied while the equipment is being installed.



CAUTION

Turn off the autopilot before aligning heading.

The autopilot may turn the rudder suddenly.



CAUTION

Confirm that the power supply voltage is compatible with the voltage rating of the equipment.

Connection to the wrong power supply can cause fire or damage the equipment.

Use the supplied power cable.

Use of a wrong power cable can cause fire or damage the equipment.

Maintain the compass safe distance to prevent deviation to a magnetic compass.

Standard compass	Steering compass
0.3 m	0.3 m

Safety Information for the Operator



WARNING

Do not disassemble or modify the equipment.

Fire, electrical shock or serious injury can result.

Turn off the power immediately if water leaks into the equipment or the equipment is emitting smoke or fire.

Continued use of the equipment can cause fire or electrical shock.

Do not place liquid-filled containers on the top of the equipment.

Fire or electrical shock can result if a liquid spills into the equipment.



CAUTION

Turn off the autopilot before selecting output data format.

The autopilot may turn the rudder suddenly.

TABLE OF CONTENTS

- FOREWORD iv**
- SYSTEM CONFIGURATION..... v**
- EQUIPMENT LIST..... vi**

- 1. OPERATION..... 1**
 - 1.1 Controls and Indications1
 - 1.2 Turning the Power On/Off1
 - 1.3 Automatic Distortion Compensation.....3
 - 1.4 Damping Control3
 - 1.5 Selecting Output Data Format.....4

- 2. MAINTENANCE & TROUBLESHOOTING..... 5**
 - 2.1 Maintenance5
 - 2.2 Troubleshooting5
 - 2.3 Diagnostic Test.....6
 - 2.4 Error Status7
 - 2.5 Clearing the Memory.....7

- 3. INSTALLATION 8**
 - 3.1 Mounting8
 - 3.2 Connections9
 - 3.3 Correcting Magnetic Field Distortion.....10
 - 3.4 Heading Alignment.....11
 - 3.5 Setting Output Data.....12
 - 3.6 Setting Baud Rate.....13

- SPECIFICATIONS..... SP-1**
- PACKING LIST..... A-1**
- OUTLINE DRAWING D-1**
- INTERCONNECION DIAGRAM.....S-1**

FOREWORD

A Word to PG-500/C-500 Owners

Congratulations on your choice of the FURUNO PG-500 Integrated Heading Sensor, C-500 Fluxgate Heading Sensor. We are confident you will see why the FURUNO name has become synonymous with quality and reliability.

Since 1948, FURUNO Electric Company has enjoyed an enviable reputation for innovative and dependable marine electronics equipment. This dedication to excellence is furthered by our extensive global network of sales and service.

Your heading sensor is designed and constructed to meet the rigorous demands of the marine environment. However, no machine can perform its intended function unless installed, operated and maintained properly. Please carefully read and follow the recommended procedures for installation, operation and maintenance.

We would appreciate hearing from you about whether we are achieving our purposes.

Thank you for choosing FURUNO equipment.

Features

- The PG-500 uses a fluxgate magnetic sensor in conjunction with a solid-state angular rate heading.
- The C-500 uses a fluxgate magnetic sensor.
- The PG-500/C-500 can correct magnetic deviation automatically.
- The PG-500/C-500 can convert magnetic heading to true heading (requires FURUNO GPS Navigator).

CE declaration

With regards to CE declarations, please refer to our website (www.furuno.com), for further information on RoHS conformity declarations.

SYSTEM CONFIGURATION

Standard connection

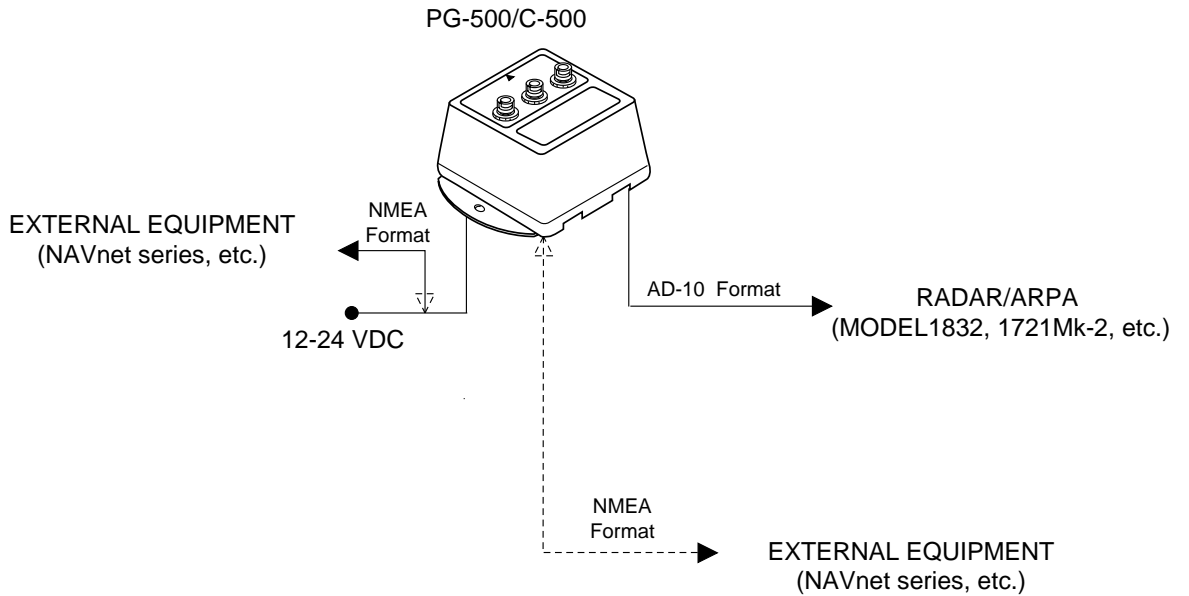

Connection with NAVpilot-500

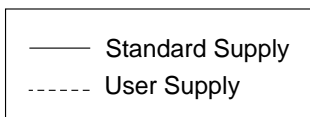
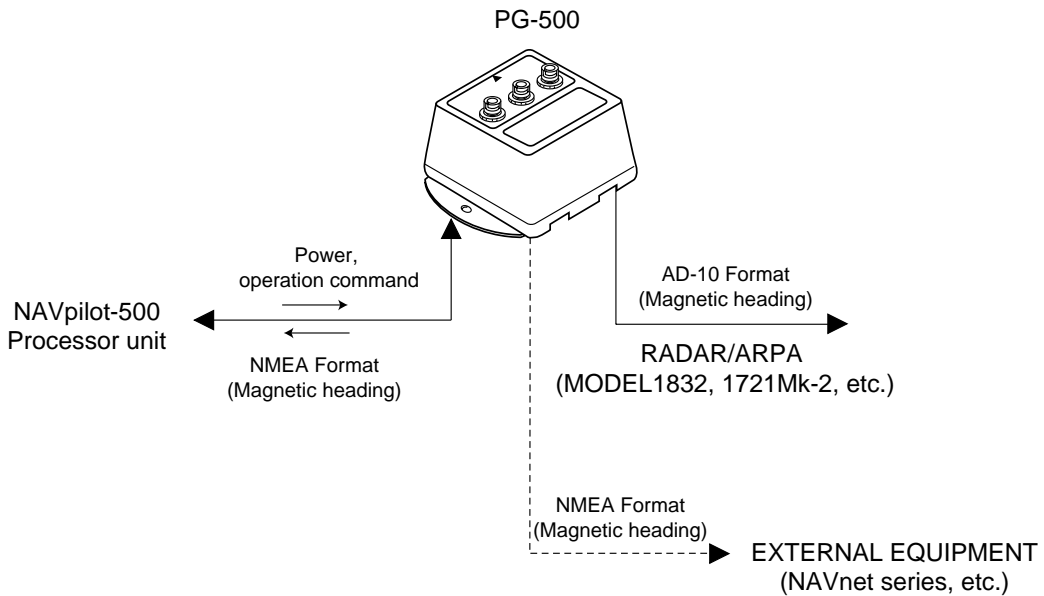

EQUIPMENT LIST

Standard set

Name	Type	Qty	Remarks
Sensor	PG-500-E	1	Fluxgate and rate sensor
	C-500-E		Fluxgate sensor
Installation Materials	-	1 set	Refer to the packing list (page A-1).
Spare Parts	-	1 set	Fuse Refer to the packing list (page A-1).

Option

Name	Type	Code No.	Qty	Remarks
Cable assy.	MJ-A6SPF0003-050	000-117-603	1	6P connector, 5 m (for AD-10 format, NMEA)
	MJ-A6SPF0007-100C	000-159-695-10	1	6P-6P, 10 m (for AD-10 format)
	MJ-A7SPF0006-100	000-143-578	1	7P-7P, 10 m (for NMEA/Power)
	MJ-A7SPF/SRMD-100	000-144-534	1	For extension. 7P-7P, 10 m

1. OPERATION

1.1 Controls and Indications

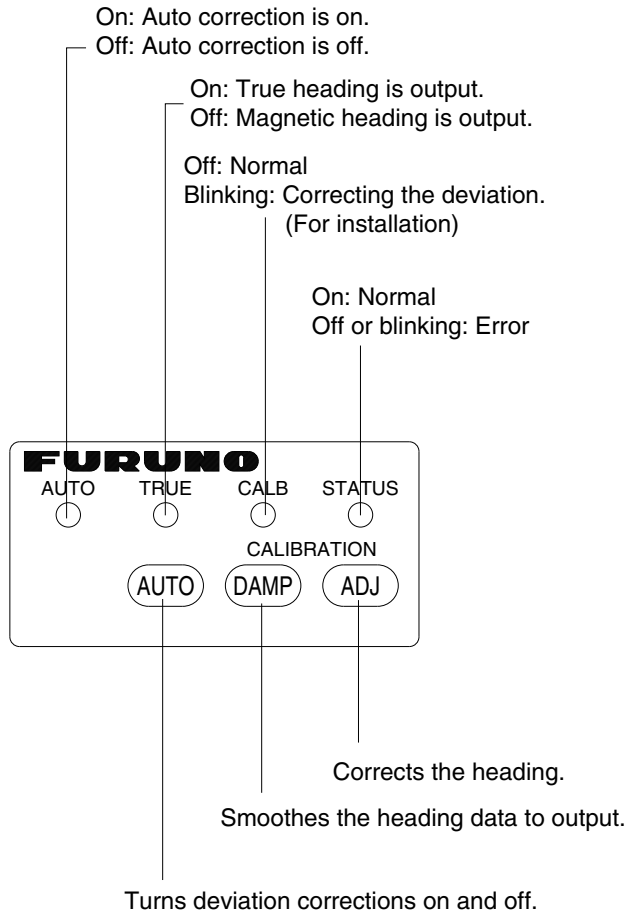

Front panel of sensor

1.2 Turning the Power On/Off

Power to the sensor may be turned on or off at the mains switchboard.

Turn the mains switch on. The sensor checks the program version, LED, ROM, RAM and deviation status in that order for proper operation.

Program version

The program version, denoted by the LEDs in binary notation, is shown. For example, the LED state shown on the next page means the program version is "1.03".

ROM, RAM check

AUTO LED lights: ROM is normal.
TRUE LED lights: RAM is normal.
(CALB and STATUS LEDs are always lit.)

Deviation status

All LEDs blink twice when the calibration is completed.

After the diagnostic tests are completed;

- C-500 outputs heading data and the STATUS LED lights immediately.
- PG-500 calculates the rate sensor offset. The STATUS LED blinks during the calculation, which takes about two minutes. When the STATUS LED lights, bearing is reliable.

Note: Confirm that the STATUS LED is lit (not blinking) before leaving port.

Sequence of Start up test

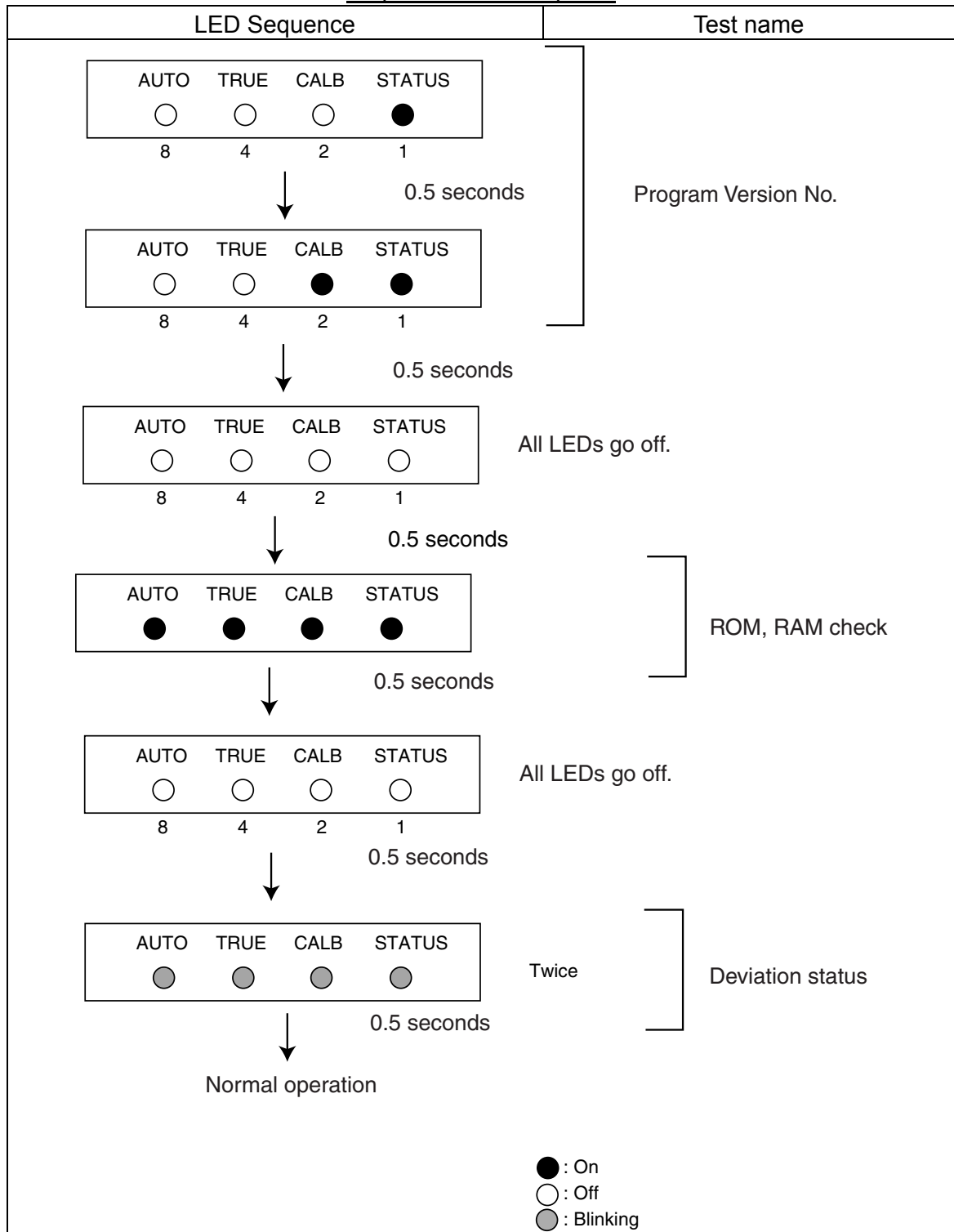

1.3 Automatic Distortion Compensation

Magnetic field distortion on your vessel has been compensated at the installation. When the magnetic field distortion changes, it can be compensated automatically as follows.

Note: This function is only effective after compensating for magnetic field distortion. (Refer to page 10.)

1. Press the [AUTO] key more than two seconds to light the AUTO LED.

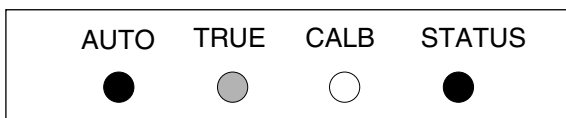

- : On
- : Off
- (grey) : State depends on settings

Auto compensation

The STATUS LED lights during the automatic distortion compensation functions.

2. To cancel automatic compensation, press the [AUTO] key more than two seconds, to turn off the AUTO LED.

Note 1: Do not conduct this procedure when your boat is near a steel ship or iron bridge, since they affect sensor performance.

Note 2: Correct distortion whenever you feel heading error is excessive.

1.4 Damping Control

The damping control determines how sensitively the sensor responds to change of ship's heading. When the damping value is large, the sensor responds smoothly but a small boat may wander after the turning. Use a small damping value as possible.

Note: When connecting with the autopilot NAVpilot-500, use the default damping setting (PG-500: damping 1, C-500: damping 2).

1. Press the [DAMP] key more than two seconds.

All LEDs go off, and then the current damping setting is shown by the LEDs.

2. Press the [DAMP] key to change the damping setting in the sequence of damping 1→2→3→4→1→...

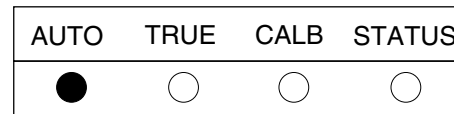

Damping 1



Damping 2

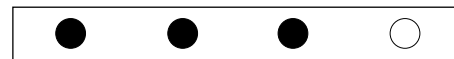

Damping 3

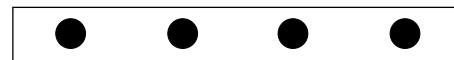

Damping 4

- : On
- : Off

Damping LED state

If three seconds passes with no operation, the damping setting is fixed, and the damping control mode is terminated.

1.5 Selecting Output Data Format

The sensor can output true or magnetic heading. The default setting is magnetic, in AD-10 format.

CAUTION

Turn off the autopilot before selecting output data format.

The autopilot may turn the rudder suddenly.

To output true heading, do the following:

1. Connect Furuno GPS Navigator which can output data sentence RMC or VTG.
2. Set up magnetic variation (manual or automatic) at the GPS Navigator.
When RMC or VTG is input to the sensor, the TRUE LED lights and then true heading is output to other equipment.
4. To return to magnetic heading output, disconnect the GPS Navigator.

Note 1: If the TRUE LED does not light within 90 seconds, check the navigator setting and cable connection.

Note 2: If the sensor stops receiving magnetic variation data while outputting true heading, the TRUE LED stops lighting and blinks. The last-used variation data is used.

Note 3: Magnetic variation cannot be corrected manually at the sensor. Therefore, if you desire true heading output but do not have a navigation aid, you may enter appropriate variation as shown in 3.4 Heading Alignment on page 11. HDM sentence, however, cannot be changed to true heading. For HDG sentence, it can be changed to true heading at the equipment connected, by using the magnetic heading and magnetic variation data in the sentence.

2. MAINTENANCE & TROUBLESHOOTING

2.1 Maintenance

Regular maintenance is important to maintain intended performance over a long period. Regularly check the following:

- Clean the component with a soft cloth. Do not use chemical cleaners; they can remove paint and markings.
- Make sure all connections are tight.
- Check the ground terminal for corrosion. Clean if necessary.

2.2 Troubleshooting

The table below provides simple troubleshooting procedures which the user can follow to restore normal operation. If normal operation cannot be restored do not check inside the equipment; there are no user-serviceable parts inside. Any repair work should be referred to a qualified technician.

Symptom	Remedy
Unit cannot be powered.	<ul style="list-style-type: none">• Check power connector.• Check the ship's mains.• Check the fuse.
LEDs do not light.	<ul style="list-style-type: none">• Check power connector.• Do the diagnostic test. (Refer to the next page.)
Heading data error.	<ul style="list-style-type: none">• Do the diagnostic test. (Refer to the next page.)
The heading data is not output to external equipment.	<ul style="list-style-type: none">• Check connections.• Do the diagnostic test. (Refer to the next page.)

2.3 Diagnostic Test

This equipment has a diagnostic test which checks the LED, key operation, ROM, RAM, EEPROM, magnetic sensor, rate sensor (PG-500 only) and loop back for proper operation. Do this test after dismantling the sensor.

1. Disconnect the power cable from the equipment.
2. While pressing the [AUTO] and [DAMP] keys together, reattach the power cable.
3. Release the [AUTO] and [DAMP] keys when the AUTO LED lights.

Then, the test is executed in the sequence shown in the right column.

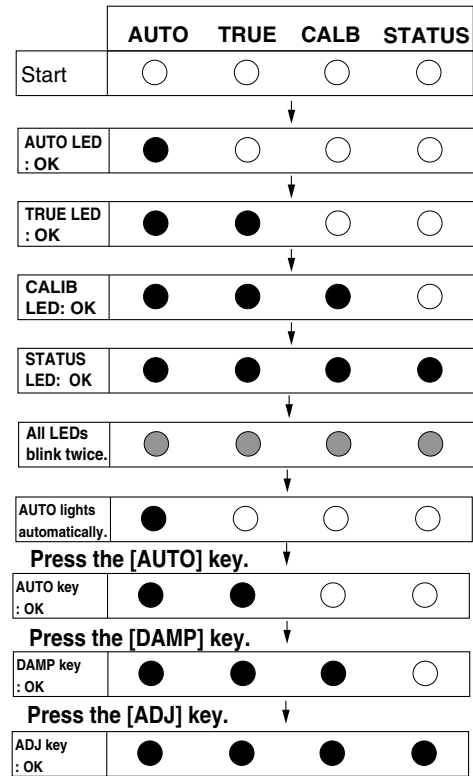

Press the [AUTO] and [DAMP] keys together again.

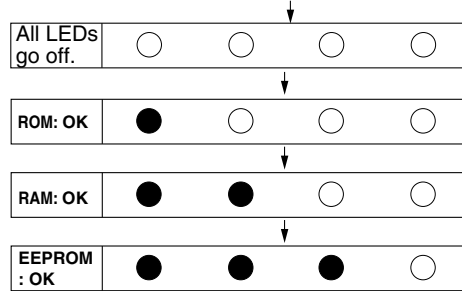

Turn the sensor more than 180° until STATUS LED lights.*1

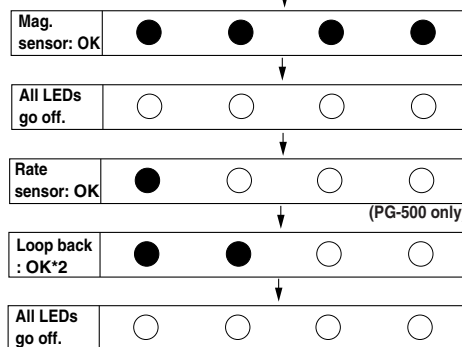

Normal operation
 ● : On (normal) ○ : Off (error) ● : Blink

Sequence of diagnostic test

*1: If STATUS LED does not light (NG), this test cannot be carried out. Contact your dealer.

Also, if the sensor is not turned within one minute after the EEPROM test, the test is carried out with the "Mag sensor" is NG.

*2: The loop back test requires a special test connector. It is skipped when the test connector is not connected.

2. MAINTENANCE & TROUBLESHOOTING

2.4 Error Status

When error is detected, all LEDs go off and then the STATUS LED blinks or goes off depending on error type as shown in the table below.

LED status	Meaning	Remarks
STATUS LED blinks slowly.	Magnetic deviation error	
STATUS LED blinks quickly.	EEPROM error	
STATUS LED goes off.	Other than the above.	Appropriate LED blinks. CALIB LED: Rate sensor error TRUE: Cable of the magnetic sensor is cut.

2.5 Clearing the Memory

The memory can be cleared to start afresh with default settings.

1. Disconnect the power cable from the equipment.
2. Reattach the cable while pressing the [AUTO] and [ADJ] keys together.

After the memory has been cleared, the sensor returns to the normal mode.

If the memory could not be cleared, the STATUS LED blinks quickly.

3. INSTALLATION

3.1 Mounting

This sensor must be mounted indoors on the horizontal plane.

When selecting a mounting location, keep in mind the following points:

- Vibration at the mounting location should be minimal.
- Install the sensor as far as possible from power cables and ferrous materials.
- Install the sensor near the ship's center of gravity.
- Align the bow mark with the ship's bow on the fore-and-aft-line.

Fix the sensor by using tapping screws and M4 flat washers (supplied).

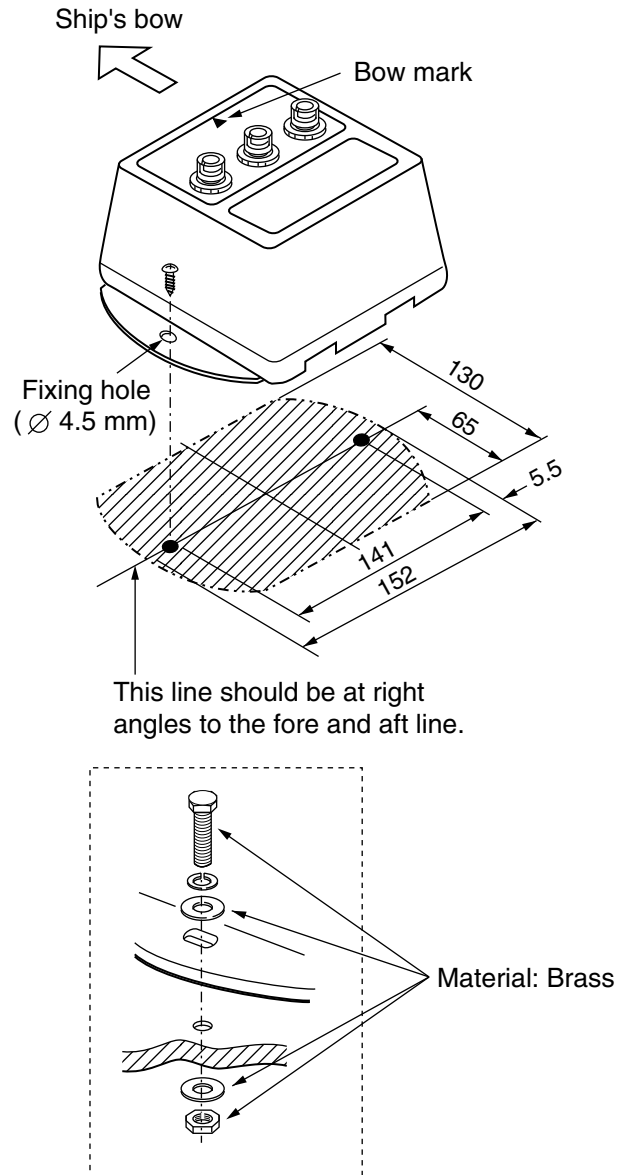

- All dimensions in mm.
- For added support, use M4 nuts, bolts and washers instead of tapping screws.
- Secure sufficient clearance around the sensor for maintenance and checking.

Mounting the sensor

Note: Do not overtighten the screws or bolts; the sensor may crack.

3. INSTALLATION

3.2 Connections

Connect cables as shown below. Leave sufficient slack in cables for maintenance and checking ease. If cables run outside the bridge, run them through conduit to protect them from corrosion.

Note: The NMEA port (the mid position) can receive and send data. However, when connecting with the NAVpilot-500 or RD-30, the NMEA port is for output only.

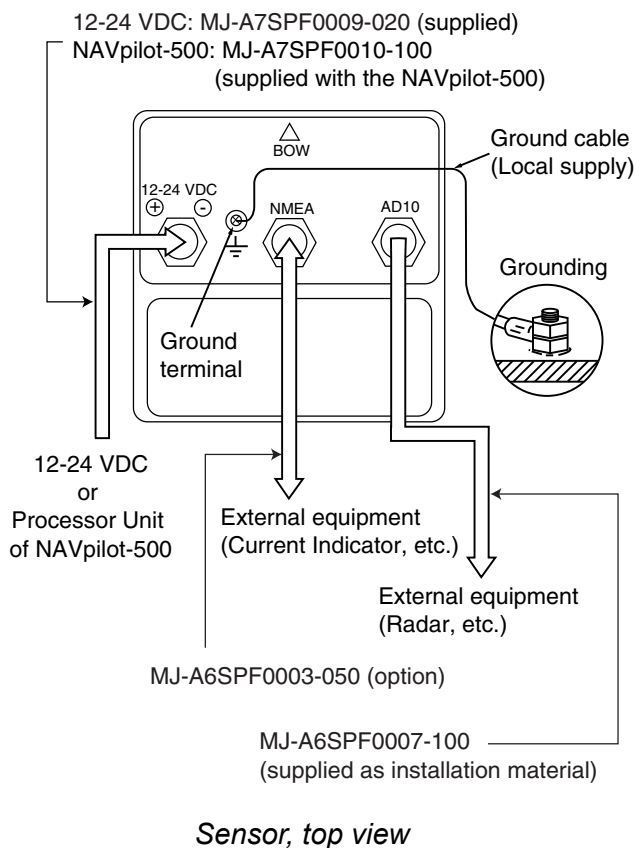

Grounding

Ground the equipment as follows to prevent loss of sensitivity:

- The ground wire should be as short as possible.
- The ground wire should be about 1.25 sq and not contain steel.
- Use only a closed-end lug.

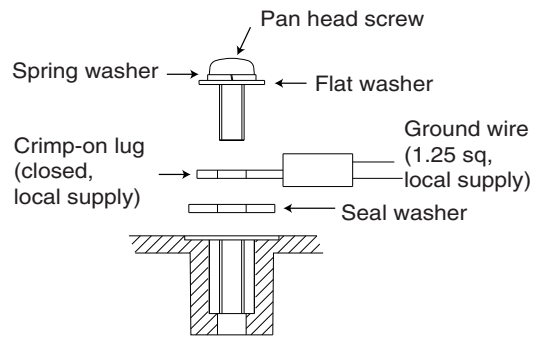

Ground terminal, sectional view

Connection of external equipment

NMEA: Digital interface NMEA format input/output terminal.

Output: HDG, HDT, HDM (Magnetic Heading)

Input*: RMC or VTG

AD-10: Outputs heading information in AD-10 format.

12-24VDC: Power input, Digital interface NMEA format input/output terminal

Output: HDG, HDT, HDM (Magnetic Heading)

Input*: RMC or VTG

***Only one port can be for Input.**

Note: Cover unused connector(s) with the rubber cap (supplied) to prevent ingress of water.

3.3 Correcting Magnetic Field Distortion

The magnetic field around the sensor is subject to change with the ship structure, engines, electronic equipment or any ferrous materials in the vicinity.

The equipment contains an automatic magnetic field distortion correction facility. Do the following to correct magnetic field distortion on calm water.

1. Steer the boat clockwise or counterclockwise in a circular course. Take about two minutes to complete the circle (at about 3 kt). While turning the boat, go to step 2.

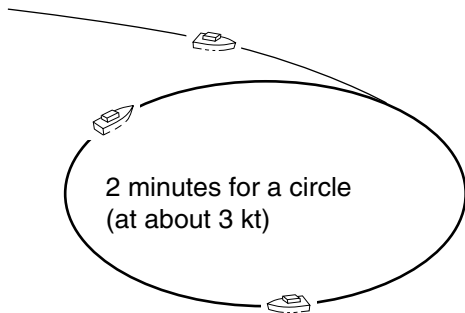

Note: Complete circle within 2 minutes, otherwise large error may result.

2. Press [ADJ] and [DAMP] keys together more than two seconds. The CALB LED blinks.

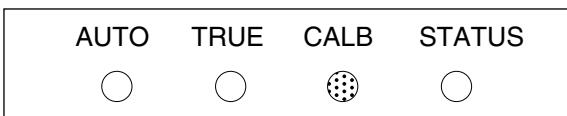

●: Blinking
○: Off

LED status during compensation

Note: You can return to normal operation at any time by pressing the [DAMP] key.

3. Continue turning the boat in a circle (three to five times) until a result is shown with the LEDs. When correction is successful, all LEDs

light. Wait 30 seconds for the sensor to return to normal operation, or press any key for quick return.

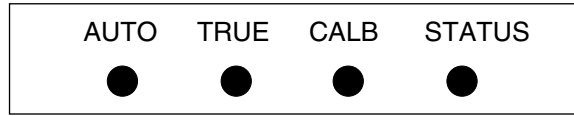

●: On

LED status at successful correction

- Note 1:** Do not turn off the power supply during the correction. Data may be corrupted.
- Note 2:** Continue turning the boat even if the CALB LED status changes from blinking to lighting. Keys are inoperative when the CALB LED is lighting.
- Note 3:** The sensor does not output heading data during the correction.

4. Anchor the boat at the pier to check sensor heading to a known point (for example, lighthouse). If there is error, see "3.4 Heading Alignment." If some LED does not light, change sensor location and repeat step 2 through 4.

If the correction failed, the LED status is as shown below. This continues until you press any key to clear the display. (Turning off the power at switchboard will not clear the LED display.) Try the correction again.

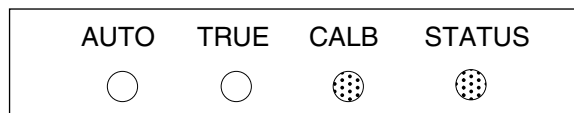

●: Blinking
○: Off

LED status, compensation failed

3. INSTALLATION

3.4 Heading Alignment

Heading alignment is required when sensor heading is different from actual heading. This alignment must be done using magnetic heading (default setting).

 CAUTION
<p>Turn off the autopilot before aligning heading.</p> <p>The autopilot may turn the rudder suddenly.</p>

Procedure

1. Press the [ADJ] key more than two seconds. All LEDs go off.

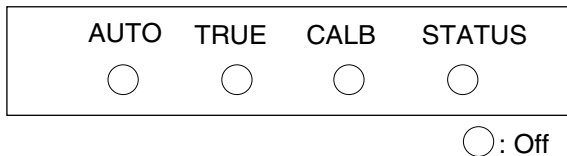

Note: Complete the next step within 10 seconds, otherwise normal operation is restored.

2. Set difference between sensor heading (output) and actual heading with the [DAMP] key for "+" or [ADJ] key for "-". For example, the heading output by the sensor is 70° and the actual heading is 75°. Therefore, the difference is +5°. Press the [DAMP] key five times to set +5°. Each time the [DAMP] key is pressed, the LEDs light as shown below.

	AUTO	TRUE	CALB	STATUS
+1°	●	○	○	○
+2°	●	●	○	○
+3°	●	●	●	○
+4°	●	●	●	●
+5°	○	○	○	○
+6°	●	○	○	○
+7°	●	●	○	○
⋮	Repeat			

●: On
○: Off

LED state and pressing of [DAMP] key

When pressing the [ADJ] key, the above sequence begins from the STATUS LED side.

3.5 Setting Output Data

Setting output interval

The default setting is 200 ms.

Refer to the table shown on the next page for proper setting.

1. Disconnect the power connector from the sensor.
2. Reattach the connector to the sensor while pressing the [DAMP] key. The equipment is powered on, and the current output interval is shown by the LEDs.

	AUTO	TRUE	CALB	STATUS
1 s	●	○	○	○
200 ms	●	●	○	○
100 ms	●	●	●	○
25 ms	●	●	●	●

● : On
○ : Off

LED state and output interval

If step 2 was not completed satisfactorily, the STATUS LED blinks quickly. Try step 2 again.

3. Press the [DAMP] key to change interval.

The sensor returns to the normal mode if there is no operation for three seconds.

Setting the output sentence(s)

Select which type(s) of heading data to output. The default setting is HDG.

1. Disconnect the power connector from the sensor.
2. Reattach the connector to the sensor while pressing the [ADJ] key. The equipment is powered on, and LED(s) light to show which output sentence(s) is being output.



HDT : True heading
HDM : Magnetic heading
HDG : Magnetic heading & Magnetic variation value

AUTO LED has no function.

LED and output sentence

3. Press key corresponding to sentence to output.

Sentence	Key
HDT	[AUTO]
HDG	[DAMP]
HDM	[ADJ]

To cancel output, press the same key again.

Note 1: Several sentences may be output simultaneously. However, delay may result when the output interval is 100 ms or 200 ms.

Note 2: "HDT" outputs true heading data. However, if variation data is not input from the GPS navigator, magnetic bearing will be output.

The equipment returns to the normal mode if there is no operation for three seconds.

3. INSTALLATION

3.6 Setting Baud Rate

Set the baud rate of external equipment.
The default setting is 4800 bps.

When connecting with the NAVpilot-500, use the default setting (4800 bps).

1. Disconnect the power connector from the sensor.
2. Reattach the connector to the sensor while pressing the [AUTO] key. The sensor is powered on, and the current baud rate is shown by the LEDs.
3. Press the [AUTO] key to change the baud rate as appropriate.

	AUTO	TRUE	CALB	STATUS
4800	●	○	○	○
9600	●	●	○	○
19200	●	●	●	○
38400	●	●	●	●

●: On
○: Off

LED and baud rate

If baud rate could not be set, the STATUS LED blinks quickly. Try again.

The sensor returns to the normal mode if there is no operation for three seconds.

Relation baud rate and output interval

Baud rate	Output interval	Available sentences
4800	25	No output
	100	Up to two sentences can be output.
	200	Up to three sentences can be output.
	1000	
9600	25	HDT or HDM
	100	Up to three sentences can be output.
	200	
	1000	
19200	25	Up to two sentences can be output.
	100	Up to three sentences can be output.
	200	
	1000	
38400	25	Up to three sentences can be output.
	100	
	200	
	1000	

Note: When an error message occurs, the above sentences may be changed.

SPECIFICATIONS OF INTEGRATED HEADING SENSOR PG-500

1 GENERAL

- | | | |
|-----|--------------------|--|
| 1.1 | Heading Accuracy | 1.0°rms (horizontal)
1.5°rms (within 30°) |
| 1.2 | Display resolution | 0.1° |
| 1.3 | Follow-up | 30°/s rate-of turn |
| 1.4 | I/O Port | Input: 1 port
Output: 2 ports (one port drives 3 outputs) |
| 1.5 | Interface | |
| | Output | FURUNO AD-10 format
IEC 61162-1 (NMEA 0183 Ver2.0)
HDG, HDT, HDM |
| | Input | IEC 61162-1 (NMEA 0183 Ver1.5/2.0)
RMC, VTG |
| 1.6 | Data Update | AD-10 formatted: 25 ms
IEC 61162-1 (NMEA 0183): 100ms, 200 ms or 1 s selected |

2 POWER SUPPLY

12-24 VDC: 0.12-0.03 A

3 ENVIRONMENTAL CONDITION

- | | | |
|-----|---------------------|---|
| 3.1 | Ambient Temperature | -15°C to +55°C |
| 3.2 | Relative Humidity | 95% at 40°C |
| 3.3 | Waterproof | IP5 (IEC 60529), CFR-46 (USCG standard) |
| 3.4 | Vibration | IEC 60945 |

4 COLOR



N3.0

P A C K I N G L I S T

64AV-X-9851 -5 1/1

PG-500/C-500

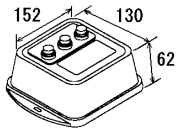
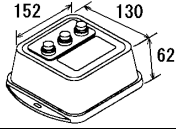
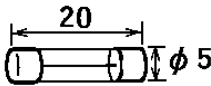
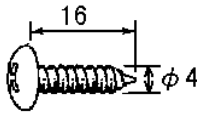
A-1

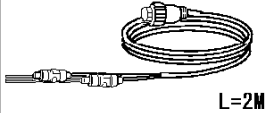
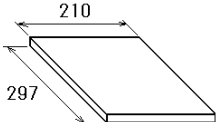
NAME	OUTLINE	DESCRIPTION/CODE No.	QTY
ユニット UNIT			
ハイブリッド heading センサー INTEGRATED HEADING SENSOR		PG-500	1 (*1)
		000-040-467-00	
フラクゲ heading センサー FLUXGATE HEADING SENSOR		C-500	1 (*1)
		000-040-468-00	
予備品 SPARE PARTS SP64-01301			
ヒューズ GLASS TUBE FUSE		FGMB-A 125V 1A PBF	2
		000-157-478-10	
工事材料 INSTALLATION MATERIALS CP64-02101			
+トラスタップインネジ 1シユ SELF TAPPING SCREW		4X16 SUS304	2
		000-162-605-10	
ミカキ丸平座金 FLAT WASHER		M4 SUS304	2
		000-167-455-10	
工事材料 INSTALLATION MATERIALS			
ケーブル組品MJ CABLE ASSY.		MJ-A6SPF0007-100C	1
		000-159-695-10	
ケーブル組品MJ CABLE ASSY.		MJ-A7SPF0009-020C	1
		000-159-686-10	
図書 DOCUMENT			
取扱説明書 OPERATOR'S MANUAL		OM*-72550-*	1
		000-147-255-1* **	

1.(*1)のユニットは仕様により決定されます。

(*1)UNIT HAS BEEN DETERMINED BY SPECIFICATION.

2.コード番号末尾の[**]は、選択品の代表コードを表します。

CODE NUMBER ENDING WITH "**" INDICATES THE CODE NUMBER OF REPRESENTATIVE MATERIAL.

(略図の寸法は、参考値です。 DIMENSIONS IN DRAWING FOR REFERENCE ONLY.)

表 1 TABLE 1

寸法区分 (mm) DIMENSIONS	公差 (mm) TOLERANCE
L ≤ 50	± 1.5
50 < L ≤ 100	± 2.5
100 < L ≤ 500	± 3

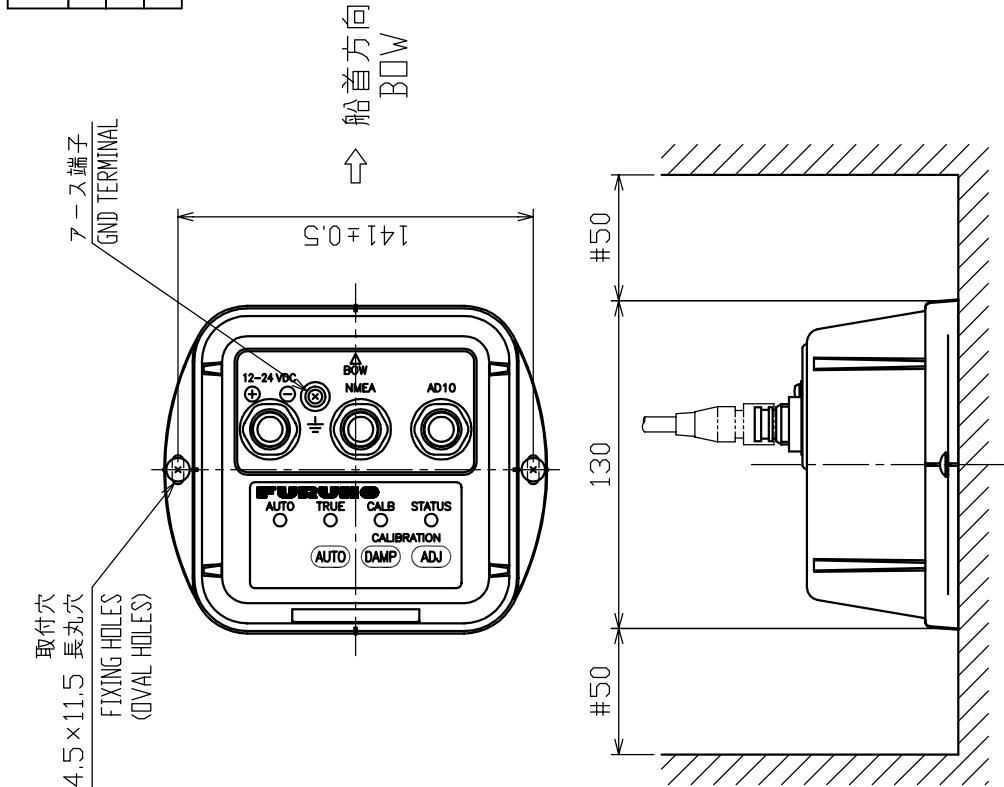

注 記

- 1) #印寸法は最小サービス空間寸法とする。
- 2) 指定外の寸法公差は表1による。
- 3) 取付用ネジは+トラスタップピンネジ呼び径4×16を使用のこと。

NOTE

1. # MINIMUM SERVICE CLEARANCE.
2. TABLE 1 INDICATES TOLERANCE OF DIMENSIONS WHICH IS NOT SPECIFIED.
3. USE SELF-TAPPING SCREWS 4X16 FOR FIXING THE UNIT.

DRAWN	MAY 27 '04 E. MIYOSHI	TITLE	PG-500/C-500
CHECKED	TAKAHASHI, T	名称	ハイブリッド Heading センサー / Heading センサー
APPROVED	Y. Hatai	外寸図	
SCALE	1/3 MASS 0.3 kg	NAME	INTEGRATED HEADING SENSOR/HEADING SENSOR
DWG No.	C7255-001-B		OUTLINE DRAWING

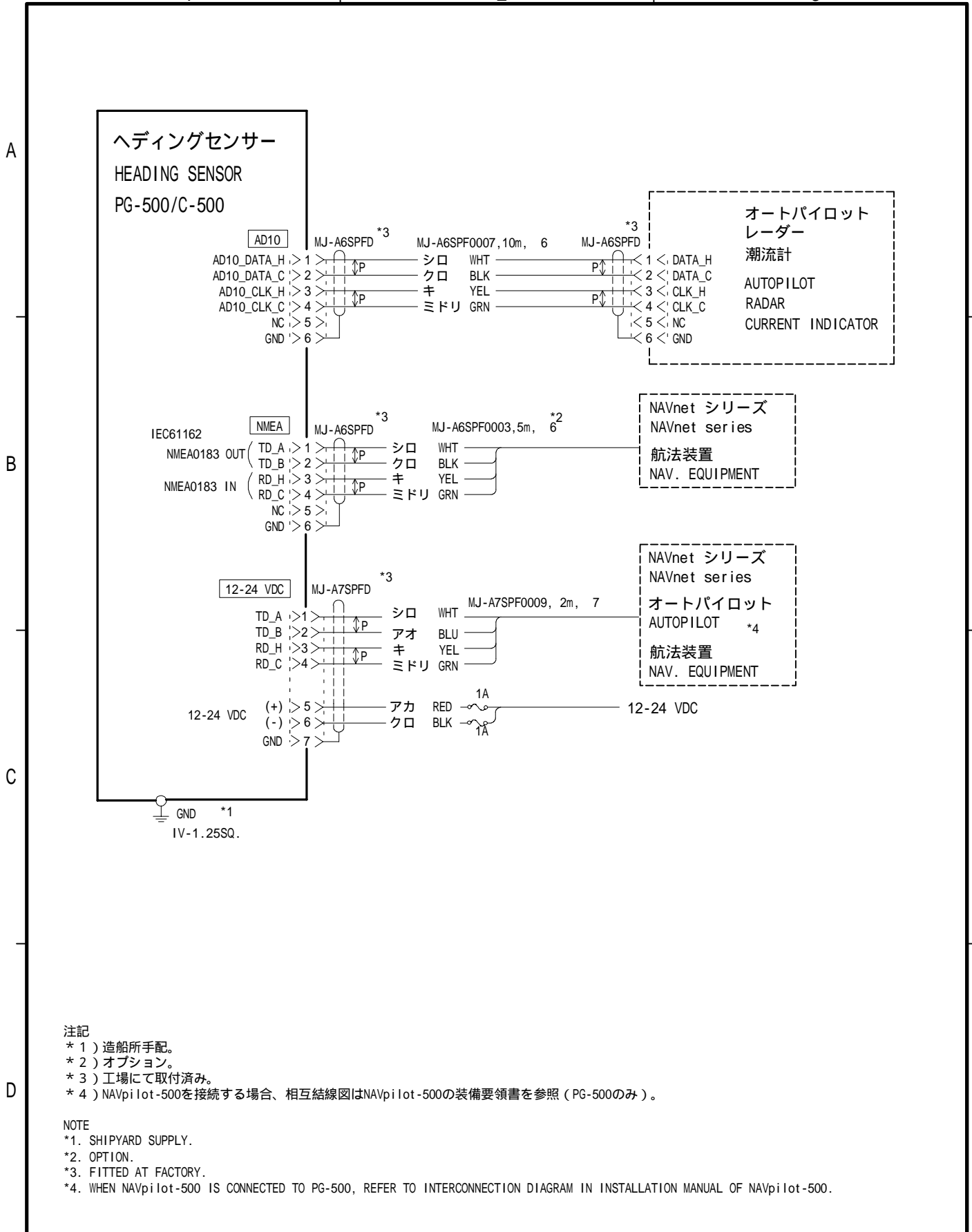

DRAWN Aug. 27, '04 E. MIYOSHI	TITLE PG-500/C-500
CHECKED TAKAHASHI.T	名称 ハイブリッドヘディングセンサー/ヘディングセンサー
APPROVED Y. Hatai	相互結線図
SCALE MASS kg	NAME INTEGRATED HEADING SENSOR/HEADING SENSOR
DWG. No. C7255-C01- C	INTERCONNECTION DIAGRAM

FURUNO Worldwide Warranty for Pleasure Boats (Except North America)

This warranty is valid for products manufactured by Furuno Electric Co. (hereafter FURUNO) and installed on a pleasure boat. Any web based purchases that are imported into other countries by anyone other than a FURUNO certified dealer may not comply with local standards. FURUNO strongly recommends against importing these products from international websites as the imported product may not work correctly and may interfere with other electronic devices. The imported product may also be in breach of the local laws and mandated technical requirements. Products imported into other countries as described previously shall not be eligible for local warranty service.

For products purchased outside of your country please contact the national distributor of Furuno products in the country where purchased.

This warranty is in addition to the customer's statutory legal rights.

1. Terms and Conditions of Warranty

FURUNO guarantees that each new FURUNO product is the result of quality materials and workmanship. The warranty is valid for a period of 2 years (24 months) from the date of the invoice, or the date of commissioning of the product by the installing certified dealer.

2. FURUNO Standard Warranty

The FURUNO standard warranty covers spare parts and labour costs associated with a warranty claim, provided that the product is returned to a FURUNO national distributor by prepaid carrier.

The FURUNO standard warranty includes:

- Repair at a FURUNO national distributor
- All spare parts for the repair
- Cost for economical shipment to customer

3. FURUNO Onboard Warranty

If the product was installed/commissioned and registered by a certified FURUNO dealer, the customer has the right to the onboard warranty.

The FURUNO onboard warranty includes

- Free shipping of the necessary parts
- Labour: Normal working hours only
- Travel time: Up to a maximum of two (2) hours
- Travel distance: Up to a maximum of one hundred and sixty (160) KM by car for the complete journey

4. Warranty Registration

For the Standard Warranty - presentation of product with serial number (8 digits serial number, 1234-5678) is sufficient. Otherwise, the invoice with serial number, name and stamp of the dealer and date of purchase is shown.

For the Onboard Warranty your FURUNO certified dealer will take care of all registrations.

5. Warranty Claims

For the Standard Warranty - simply send the defective product together with the invoice to a FURUNO national distributor. For the Onboard Warranty – contact a FURUNO national distributor or a certified dealer. Give the product's serial number and describe the problem as accurately as possible.

Warranty repairs carried out by companies/persons other than a FURUNO national distributor or a certified dealer is not covered by this warranty.

6. Warranty Limitations

When a claim is made, FURUNO has a right to choose whether to repair the product or replace it.

The FURUNO warranty is only valid if the product was correctly installed and used. Therefore, it is necessary for the customer to comply with the instructions in the handbook. Problems which result from not complying with the instruction manual are not covered by the warranty.

FURUNO is not liable for any damage caused to the vessel by using a FURUNO product.

The following are excluded from this warranty:

- a. Second-hand product
- b. Underwater unit such as transducer and hull unit
- c. Routine maintenance, alignment and calibration services.
- d. Replacement of consumable parts such as fuses, lamps, recording papers, drive belts, cables, protective covers and batteries.
- e. Magnetron and MIC with more than 1000 transmitting hours or older than 12 months, whichever comes first.
- f. Costs associated with the replacement of a transducer (e.g. Crane, docking or diver etc.).
- g. Sea trial, test and evaluation or other demonstrations.
- h. Products repaired or altered by anyone other than the FURUNO national distributor or an authorized dealer.
- i. Products on which the serial number is altered, defaced or removed.
- j. Problems resulting from an accident, negligence, misuse, improper installation, vandalism or water penetration.
- k. Damage resulting from a force majeure or other natural catastrophe or calamity.
- l. Damage from shipping or transit.
- m. Software updates, except when deemed necessary and warrantable by FURUNO.
- n. Overtime, extra labour outside of normal hours such as weekend/holiday, and travel costs above the 160 KM allowance
- o. Operator familiarization and orientation.

FURUNO Electric Company, March 1, 2011

FURUNO Warranty for North America

FURUNO U.S.A., Limited Warranty provides a twenty-four (24) months LABOR and twenty-four (24) months PARTS warranty on products from the date of installation or purchase by the original owner. Products or components that are represented as being waterproof are guaranteed to be waterproof only for, and within the limits, of the warranty period stated above. The warranty start date may not exceed eighteen (18) months from the original date of purchase by dealer from Furuno USA and applies to new equipment installed and operated in accordance with Furuno USA's published instructions.

Magnetrons and Microwave devices will be warranted for a period of 12 months from date of original equipment installation.

Furuno U.S.A., Inc. warrants each new product to be of sound material and workmanship and through its authorized dealer will exchange any parts proven to be defective in material or workmanship under normal use at no charge for a period of 24 months from the date of installation or purchase.

Furuno U.S.A., Inc., through an authorized Furuno dealer will provide labor at no cost to replace defective parts, exclusive of routine maintenance or normal adjustments, for a period of 24 months from installation date provided the work is done by Furuno U.S.A., Inc. or an AUTHORIZED Furuno dealer during normal shop hours and within a radius of 50 miles of the shop location.

A suitable proof of purchase showing date of purchase, or installation certification must be available to Furuno U.S.A., Inc., or its authorized dealer at the time of request for warranty service.

This warranty is valid for installation of products manufactured by Furuno Electric Co. (hereafter FURUNO). Any purchases from brick and mortar or web-based resellers that are imported into other countries by anyone other than a FURUNO certified dealer, agent or subsidiary may not comply with local standards. FURUNO strongly recommends against importing these products from international websites or other resellers, as the imported product may not work correctly and may interfere with other electronic devices. The imported product may also be in breach of the local laws and mandated technical requirements. Products imported into other countries, as described previously, shall not be eligible for local warranty service.

For products purchased outside of your country please contact the national distributor of Furuno products in the country where purchased.

WARRANTY REGISTRATION AND INFORMATION

To register your product for warranty, as well as see the complete warranty guidelines and limitations, please visit www.furunousa.com and click on "Support". In order to expedite repairs, warranty service on Furuno equipment is provided through its authorized dealer network. If this is not possible or practical, please contact Furuno U.S.A., Inc. to arrange warranty service.

FURUNO U.S.A., INC.
Attention: Service Coordinator
4400 N.W. Pacific Rim Boulevard
Camas, WA 98607-9408
Telephone: (360) 834-9300
FAX: (360) 834-9400

Furuno U.S.A., Inc. is proud to supply you with the highest quality in Marine Electronics. We know you had several choices when making your selection of equipment, and from everyone at Furuno we thank you. Furuno takes great pride in customer service.

EC Declaration of Conformity



We **FURUNO ELECTRIC CO., LTD.**

(Manufacturer)

9-52 Ashihara-Cho, Nishinomiya City, 662-8580, Hyogo, Japan

(Address)

declare under our sole responsibility that the product

INTEGRATED HEADING SENSOR PG-500

(Model name, type number)

to which this declaration relates is in conformity with the following standard(s) or other normative document(s)

IEC 60945 Ed.4.0: 2002, clauses 9.2, 9.3, 10.3, 10.4, 10.5, 10.8 and 10.9

IEC 60945 Ed.3.0: 1996, clauses 9.2, 9.3, 10.2, 10.3, 10.4, 10.5, 10.8 and 10.9

(title and/or number and date of issue of the standard(s) or other normative document(s))

For assessment, see

- EMC Test Report FLI 12-03-020, April 21, 2003 prepared by Furuno Labotech International Co., Ltd.

This declaration is issued according to the Directive 2014/30/EU of the European Parliament and of the Council of 26 February 2014 on the harmonisation of the laws of the Member States relating to electromagnetic compatibility.

On behalf of Furuno Electric Co., Ltd.

Nishinomiya City, Japan
April 20, 2016

(Place and date of issue)

Yoshitaka Shogaki
Department General Manager
Quality Assurance Department

(name and signature or equivalent marking of authorized person)

ECF

(Elemental Chlorine Free)

The paper used in this manual
is elemental chlorine free.

FURUNO ELECTRIC CO., LTD.

9-52 Ashihara-cho,
Nishinomiya, 662-8580, JAPAN

• FURUNO Authorized Distributor/Dealer

All rights reserved. Printed in Japan

Pub. No. OME-72550-D3

(YOTA) PG-500/C-500

A : APR. 2003

D3 : MAY 13, 2021



0 0 0 1 4 7 2 5 6 1 2