

*wdci*

Introduction to RIO Education:

# One particular view of The Education Ecosystem



Plagiarism detection tool

Online collaboration tool

Virtual classroom tool

TEACHING

# LMS

LEARNING MANAGEMENT SYSTEM

Hosts academic resources (it is not a resource library though)  
Facilitates the online component of the teaching-learning process  
Conditions the online component of the student learning experience  
Pieces of Assessment are often marked here

Scheduling tool

Document generation tool

ADMINISTRATION

# SIS

STUDENT MANAGEMENT SYSTEM

Manages non-academic aspects of the student's relationship with the institution  
Manages administrative tasks that make teaching-learning possible  
Application, enrollment, program structure, student progression, facilities, etc.

Finance tool

BUSINESS AS USUAL

# ERP

ENTERPRISE RESOURCE PLANNING TOOL

Manages those aspects related to running a business  
Staffing, contracts, real estate, invoicing, etc.

Marketing tool

BUSINESS DEVELOPMENT

# CRM

CUSTOMER RELATIONSHIP MANAGEMENT SYSTEM

Identifies leads and potential customers (students)  
Tracks our relationship with them  
Leverages information to provide insight into new opportunities for business



# wdci

Introduction to RIO Education:  
**EDA basics**

The Cloud Solutions Company

wdci



Education Institution and Program  
Are linked through the University Department

University Departments issue  
Courses and Programs

Programs mean nothing without a  
Program Plan (i.e. a 'version')

To complete a Program,  
students must comply with the Requirements  
in their Program Plan

Each Requirement consists of:  
1) a Course  
2) an attribute  
(mandatory, elective, etc.)

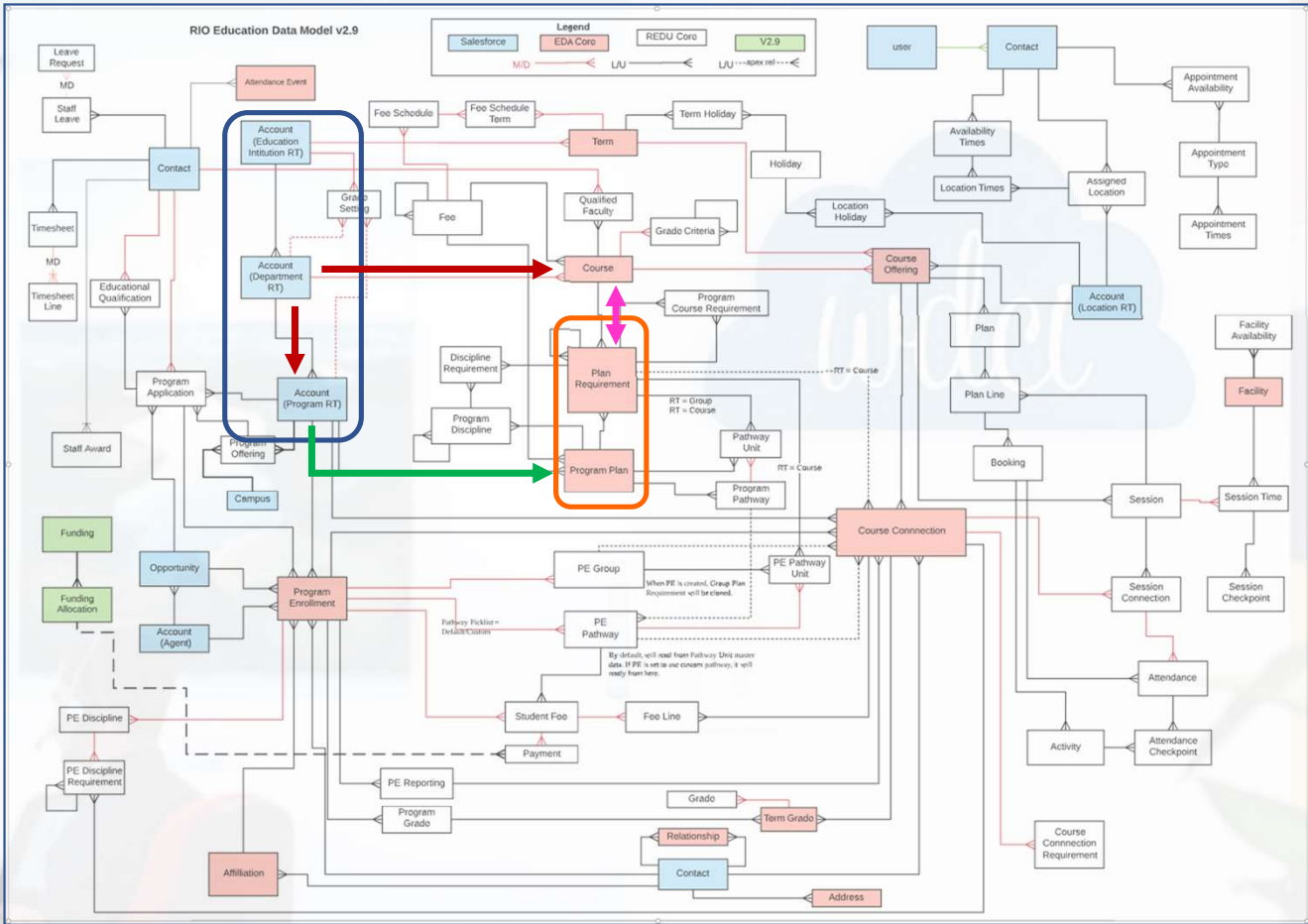

# The RIO data model. EDA basics





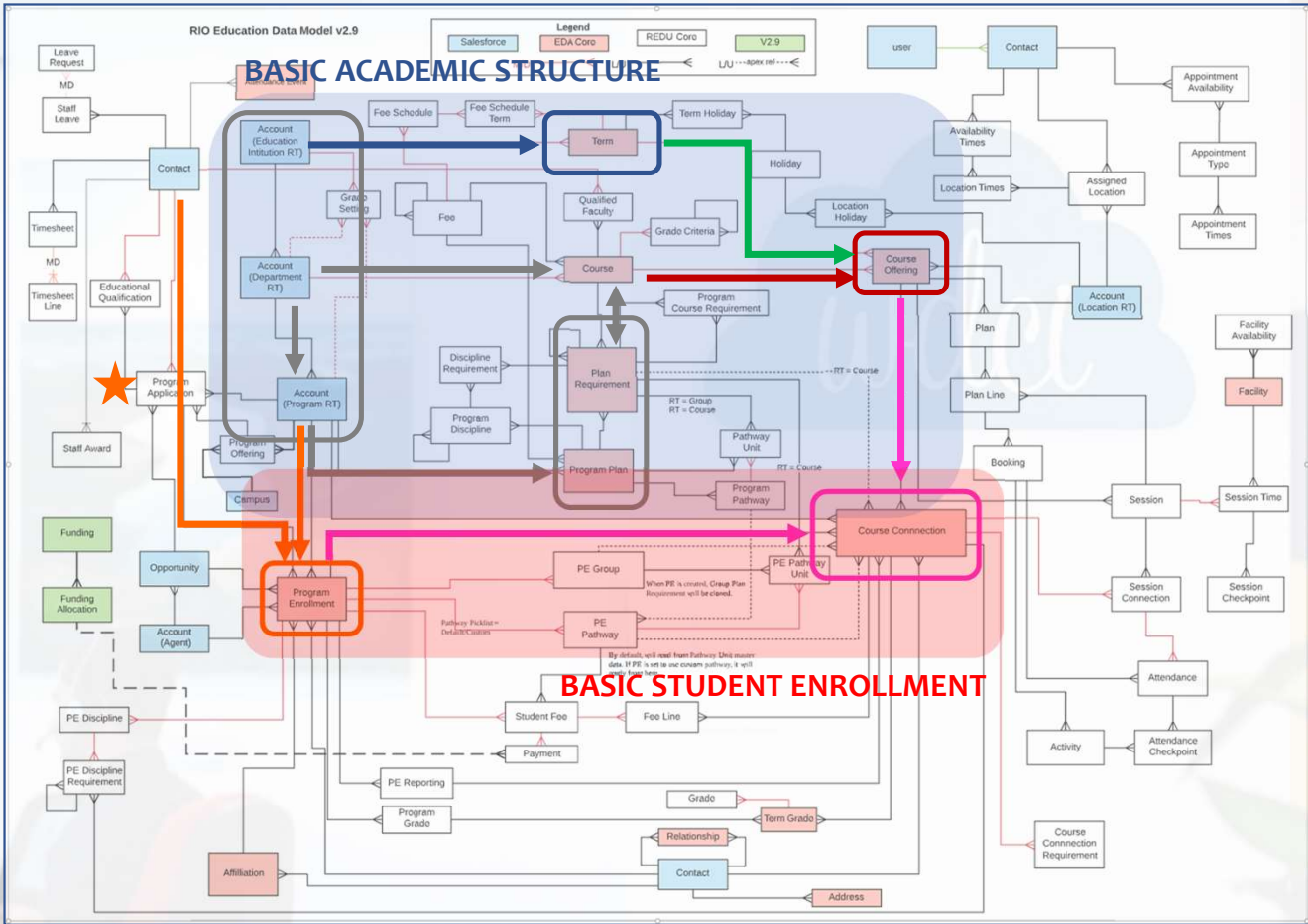

Terms are defined at the **Account** level

A Course will only exist on paper until a **Course Offering** is issued

Course Offerings use the Terms we have defined at Account level to get a **time reference** on which they start

Students come into scene only when they are admitted into a Program, which requires a record in **Program Enrollment**

However, students still have to enroll into Courses to become 'active' members of the Program: **Course Connection**

# The RIO data model. EDA basics



# wdci

Introduction to RIO Education:

## Pathways

The Cloud Solutions Company

wdci



Plan Requirements are just a list of courses:

**Program  
Plan**



# Plan Requirements

wdci

- 1
- 2
- 3
- 4
- 5
- 6
- 7
- 8
- 9
- 10
- 11
- 12



Plan Requirements are just a list of courses:

They are not even ordered!

**Program Plan**



# Plan Requirements

@  
# Term 1  
\$  
% Term 2  
^  
&  
\* Term 3  
(  
)  
! Term 4  
?  
+

**Pathways**







RIO Education Data Model v2.9

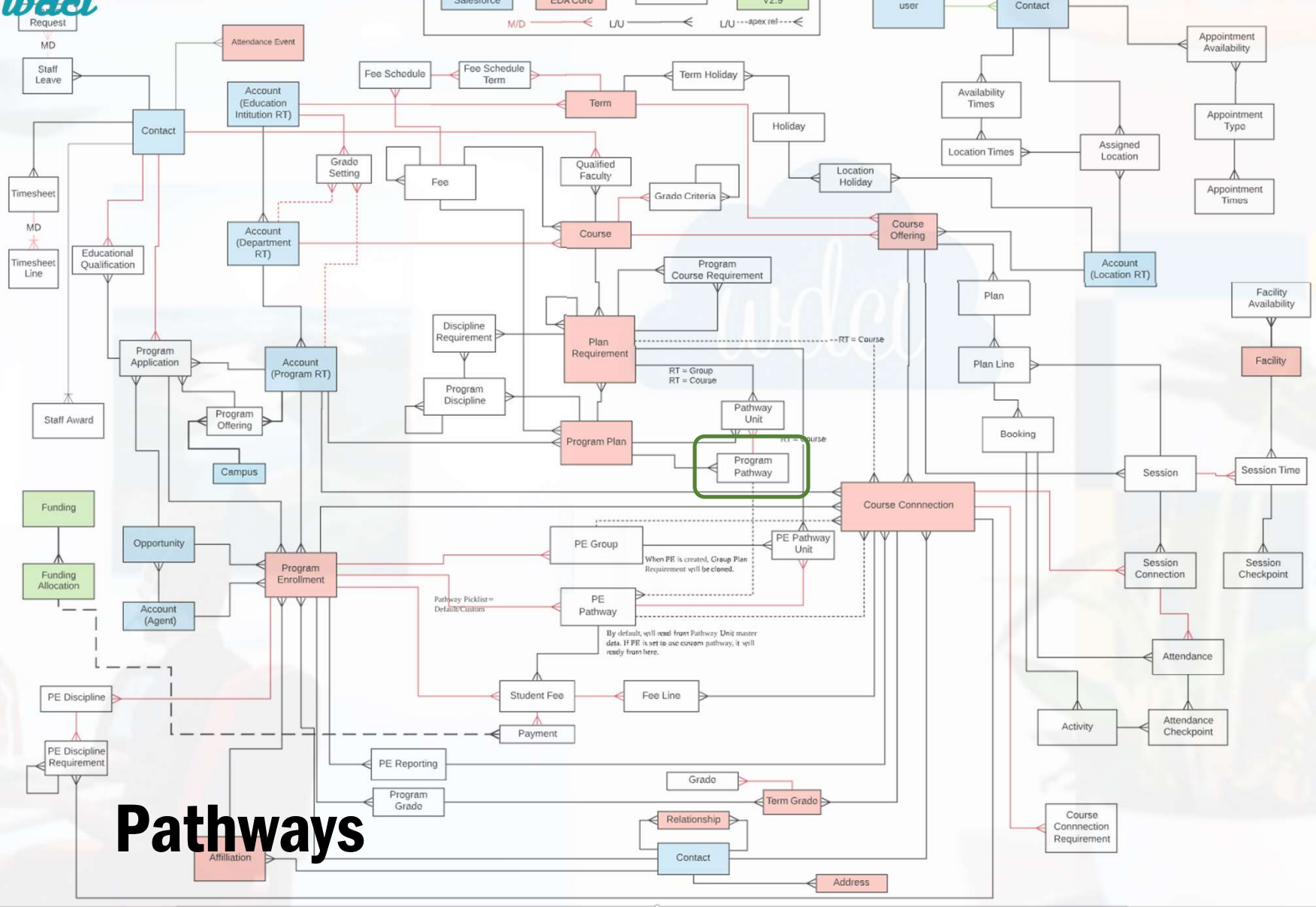

# Pathways

## A Pathway

is a concept in RIO Education that refers to the recommended path through a program

Pathways suggest students what courses to take in each term





RIO Education Data Model v2.9

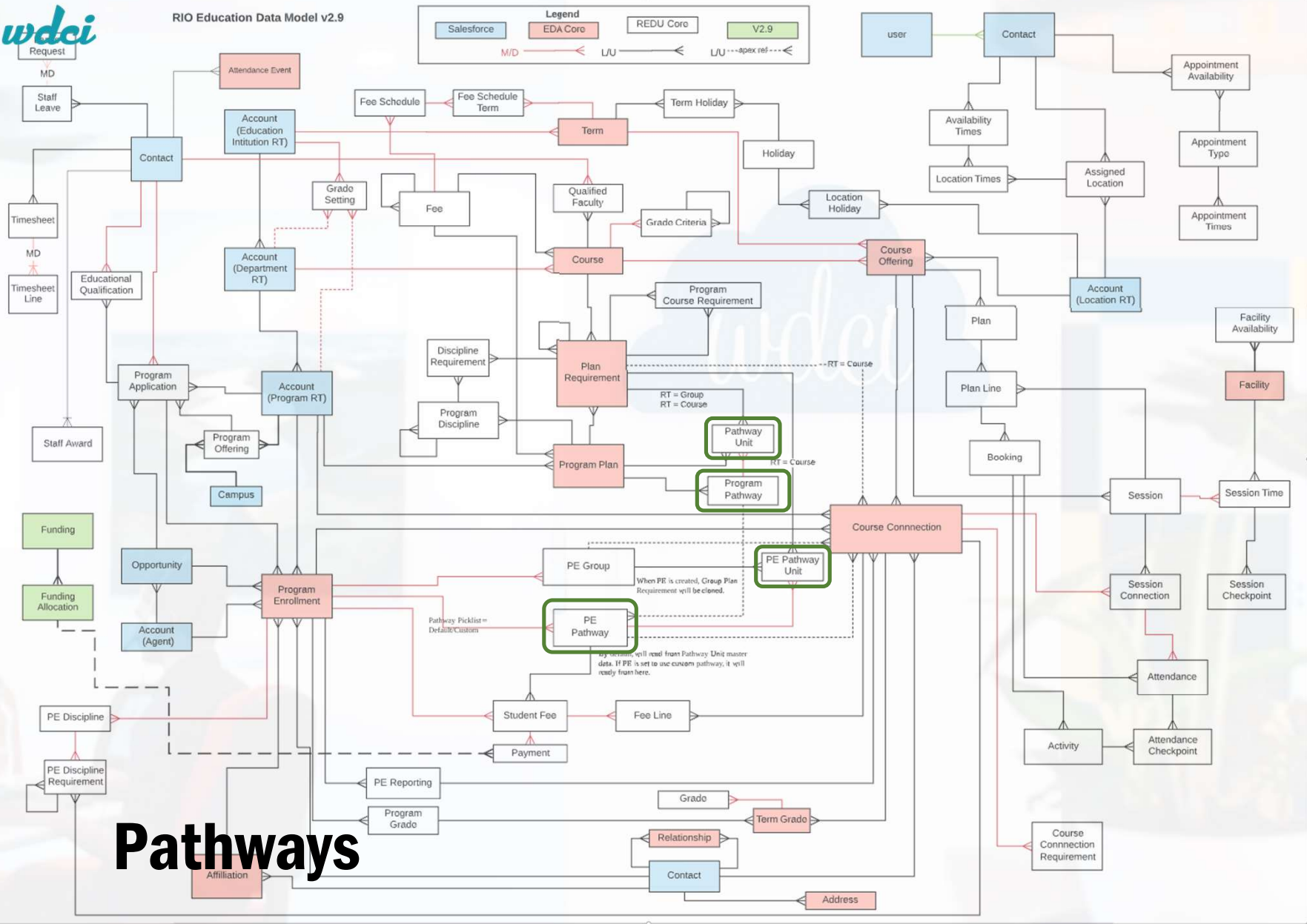
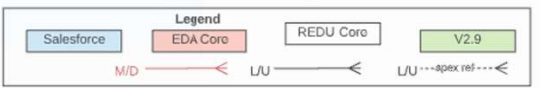

# Pathways

There are **FOUR** RIO objects related to pathways



**Program  
Plan**



# Plan Requirements

1

2

3

Term 1

4

5

6

Term 2

7

8

9

Term 3

10

11

12

Term 4

**Program Pathway**





RIO Education Data Model v2.9

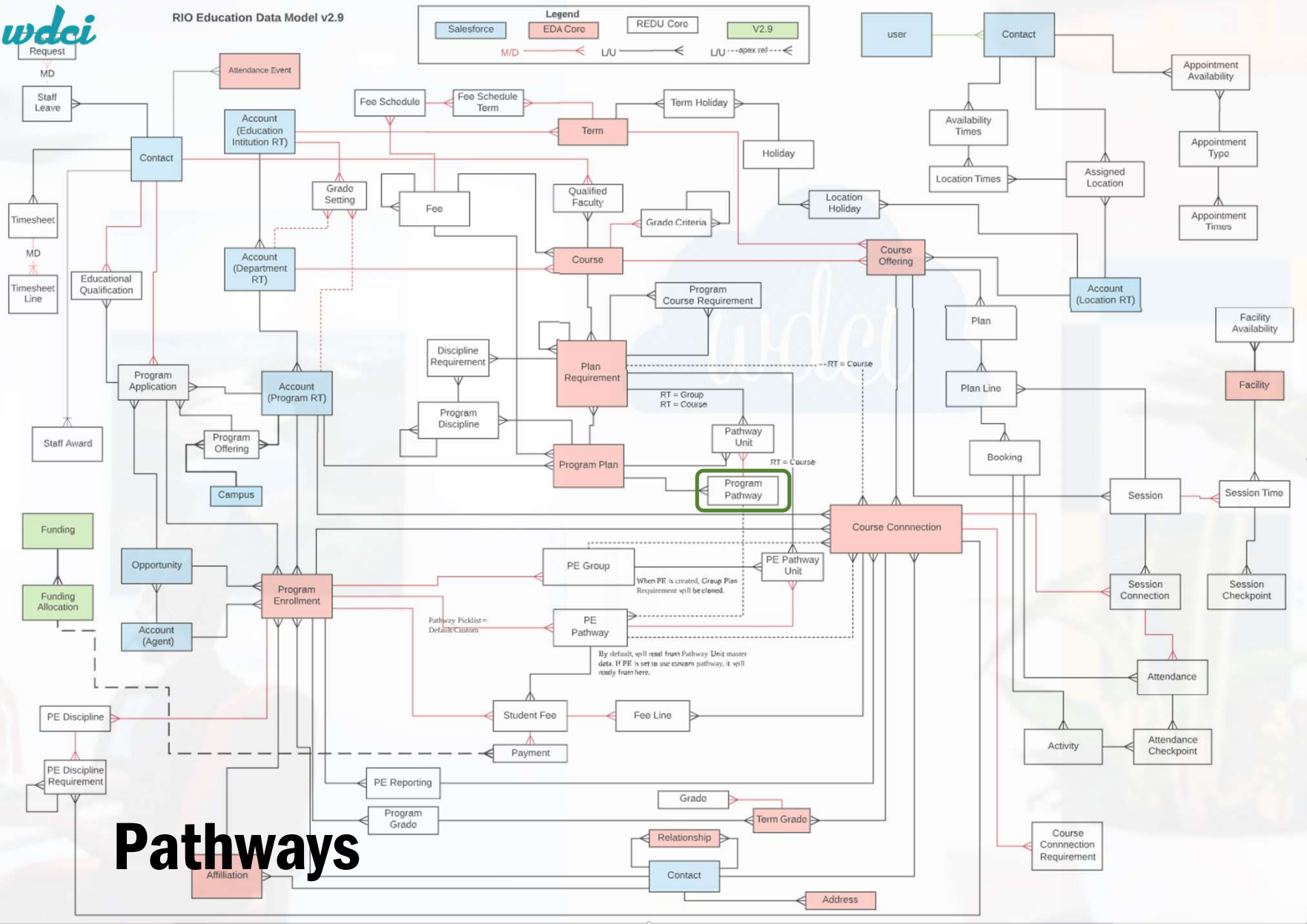

# Pathways

**Program Pathway:**  
 A template showing the recommended progression within a Program

Examples:

Full-time  
 Part-time







RIO Education Data Model v2.9

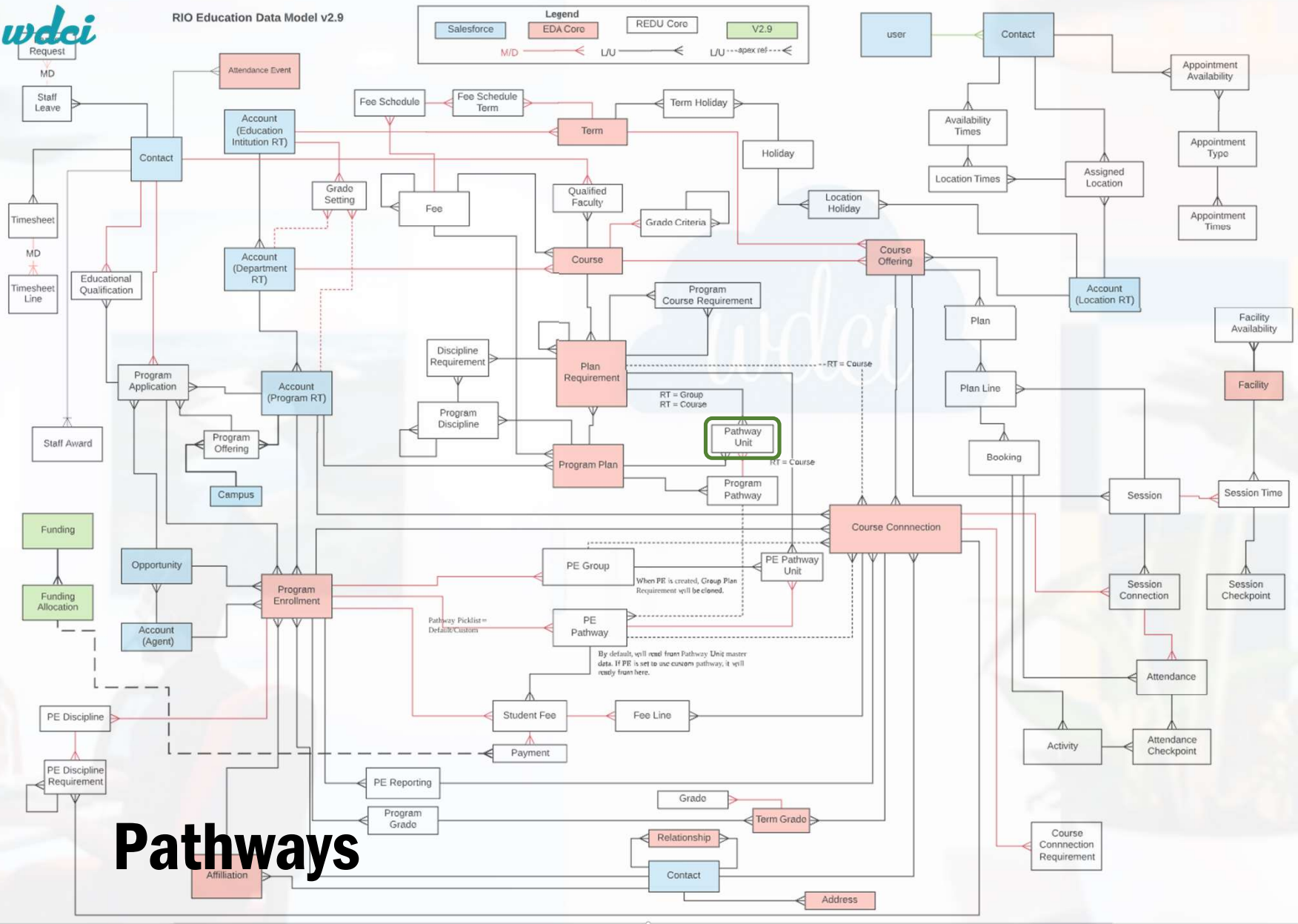

# Pathways

## Pathway Unit(s):

A list of the Requirements and the recommended Terms for each.

One list per each Program Pathway.

Example:

Unit 1 - Term 1  
Unit n - Term n  
...



Account Bachelor of Business Information System

Account Record Type: Academic Program  
Parent Account: School of Business  
Website



- Details
- Grade Settings
- Program Versions**
- Program Offering

Program Plans (2) New

Program Plan Name	Start Date	End Date	Status
Bachelor of Business Information System V1	1/01/2018		Current
Bachelor of Business Information System Initial	1/01/2015	31/12/2017	Archived

[View All](#)

# Pathways in action



Program Plan  
**Bachelor of Business Information System V1**

Start Date  
1/01/2018

End Date



- Details
- Program Structure
- Pathways
- Program Enrollments
- Program Disciplines

Program Pathways (2)

2 Items · Updated a few seconds ago

<input type="checkbox"/>	Program Pat... ▾	Notes ▾	Number of... ▾	Study Mode ▾
1	<input type="checkbox"/> PP-0008	Full time study for the Bachelor of Business Management	6	Full-time ▾
2	<input type="checkbox"/> PP-0009	Part time study (with 2 courses per semester) for the Bachelor of Business Management	12	Half-time ▾

[View All](#)

# Pathways in action Program Pathways



Program Pathways > PP-0008  
Pathway Units

20 Items • Sorted by Term Number • Updated a minute ago

	Pathway Unit ID	Term Number	Plan Requirement (Group)	Number of Units from Group	Plan Requirement (Unit)	Unit ID	
1	PPU-0107	1			RIOUNI022018 - BUS101	BUS101	▼
2	PPU-0108	1			RIOUNI022018 - BUS102	BUS102	▼
3	PPU-0109	1			RIOUNI022018 - ICT112	ICT112	▼
4	PPU-0110	1			RIOUNI022018 - ICT115	ICT115	▼
5	PPU-0111	2			RIOUNI022018 - BUS105	BUS105	▼
6	PPU-0112	2	RIOUNI01-Electives	2			▼
7	PPU-0113	2			RIOUNI022018 - ICT221	ICT221	▼
8	PPU-0114	2			RIOUNI022018 - BUS104	BUS104	▼
9	PPU-0115	3			RIOUNI022018 - BUS108	BUS108	▼
10	PPU-0116	3			RIOUNI022018 - ICT310	ICT310	▼
11	PPU-0117	3	RIOUNI02-Electives	2			▼
12	PPU-0118	4			RIOUNI022018 - BUS211	BUS211	▼
13	PPU-0252	4			RIOUNI022018 - HRM321	HRM321	▼
14	PPU-0120	5			RIOUNI022018 - BUS203	BUS203	▼
15	PPU-0121	5			RIOUNI022018 - ICT211	ICT211	▼
16	PPU-0122	5			RIOUNI022018 - ICT320	ICT320	▼
17	PPU-0123	5	RIOUNI02-Electives	1			▼
18	PPU-0124	6			RIOUNI022018 - ICT352	ICT352	▼
19	PPU-0125	6			RIOUNI022018 - MGT325	MGT325	▼
20	PPU-0126	6	RIOUNI02-Electives	2			▼

Pathways in action Pathway Units





Program Pathways are basically templates only

## **What if a student does not fit into any of the default Program Pathways?**

For example: A student with special circumstances



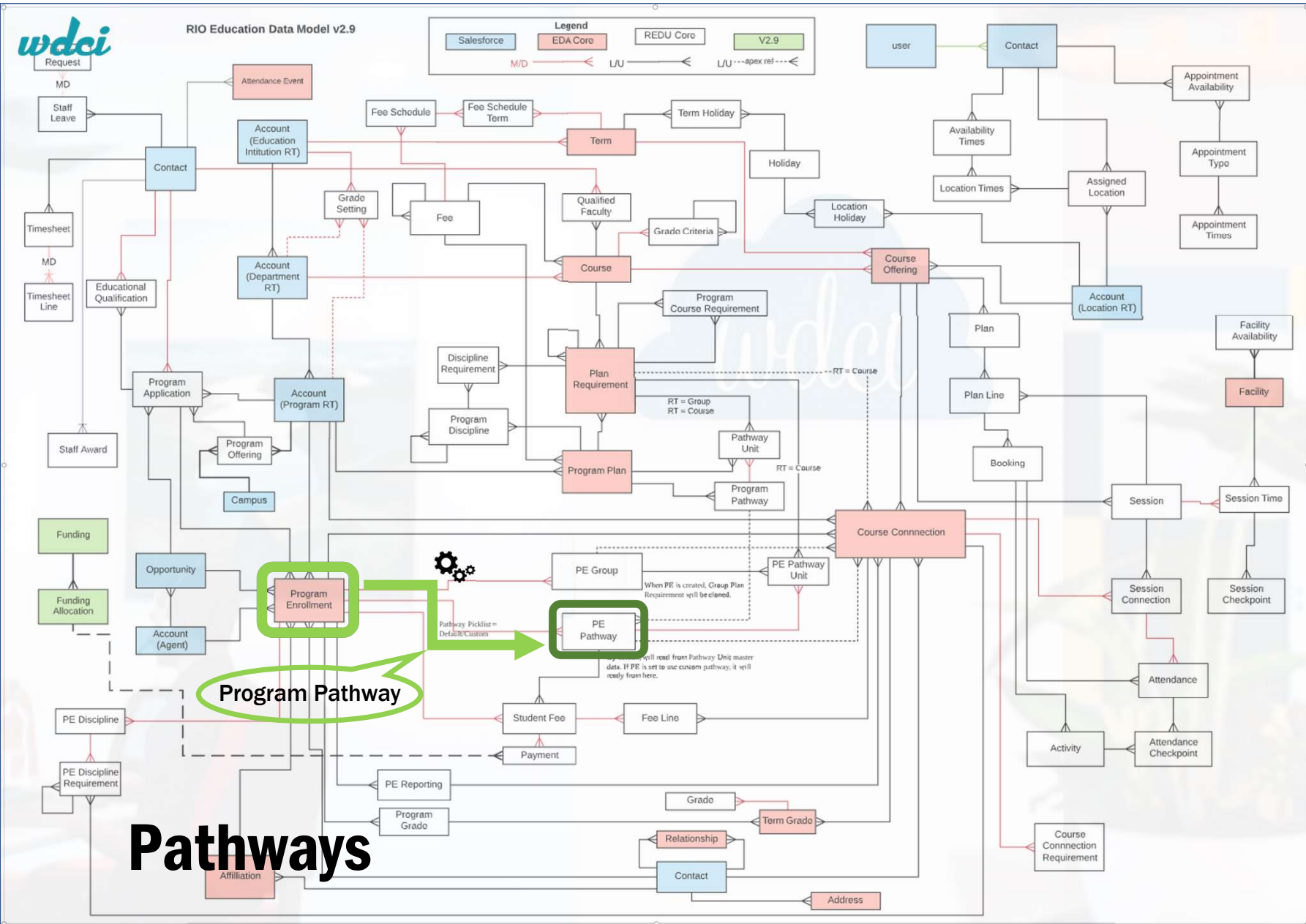

# Program Enrollment Pathway:

Each student enrolled in a Program has their own PE Pathway

Examples:

- Full-time John
- Part-time Mary





RIO Education Data Model v2.9

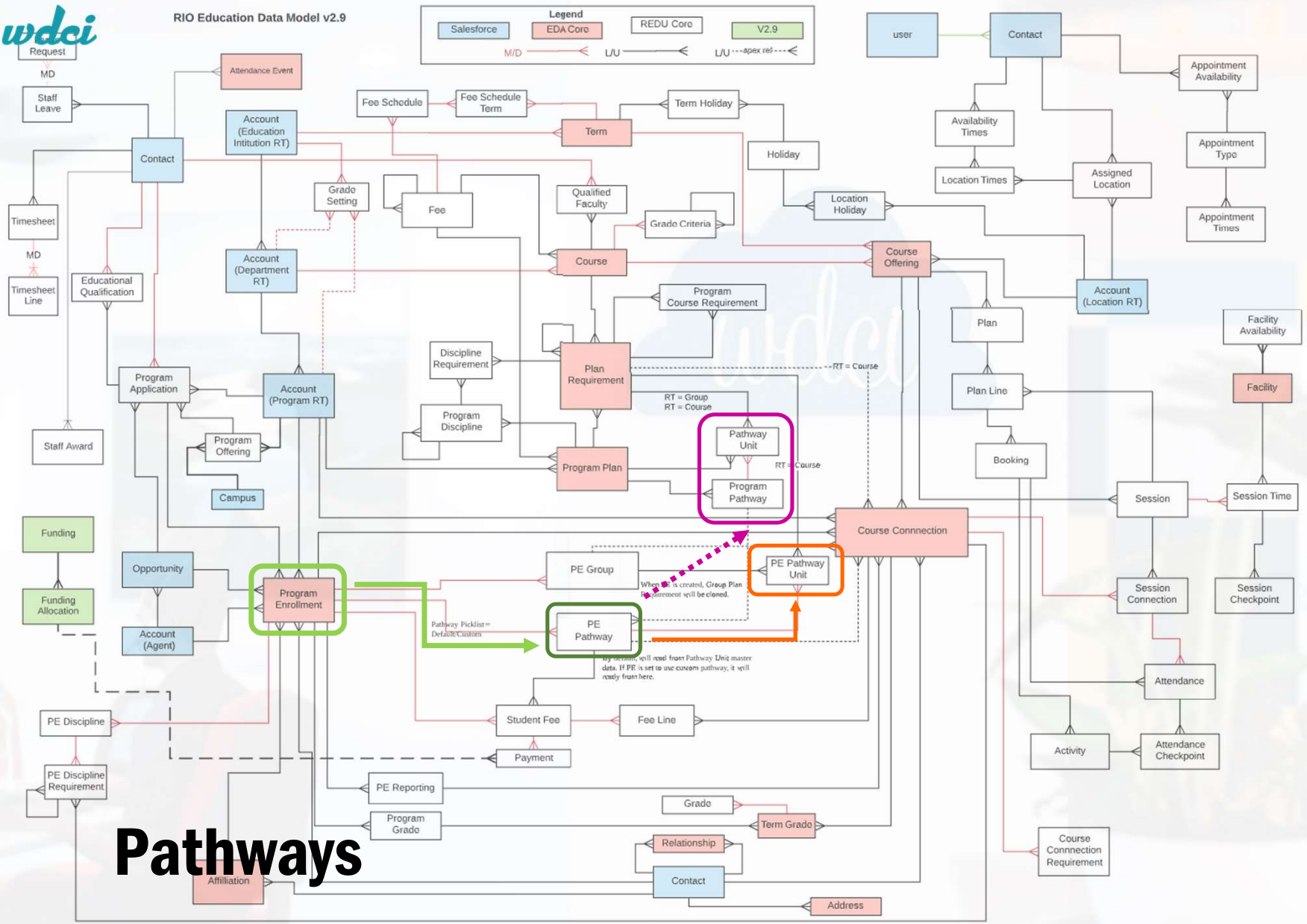

# Pathways

## Program Enrollment Pathway.

### Two options:

A) Use one of the default pathways

B) Create a specific list:  
The Program Enrolment (PE) Pathway Unit object





RIO Education Data Model v2.9

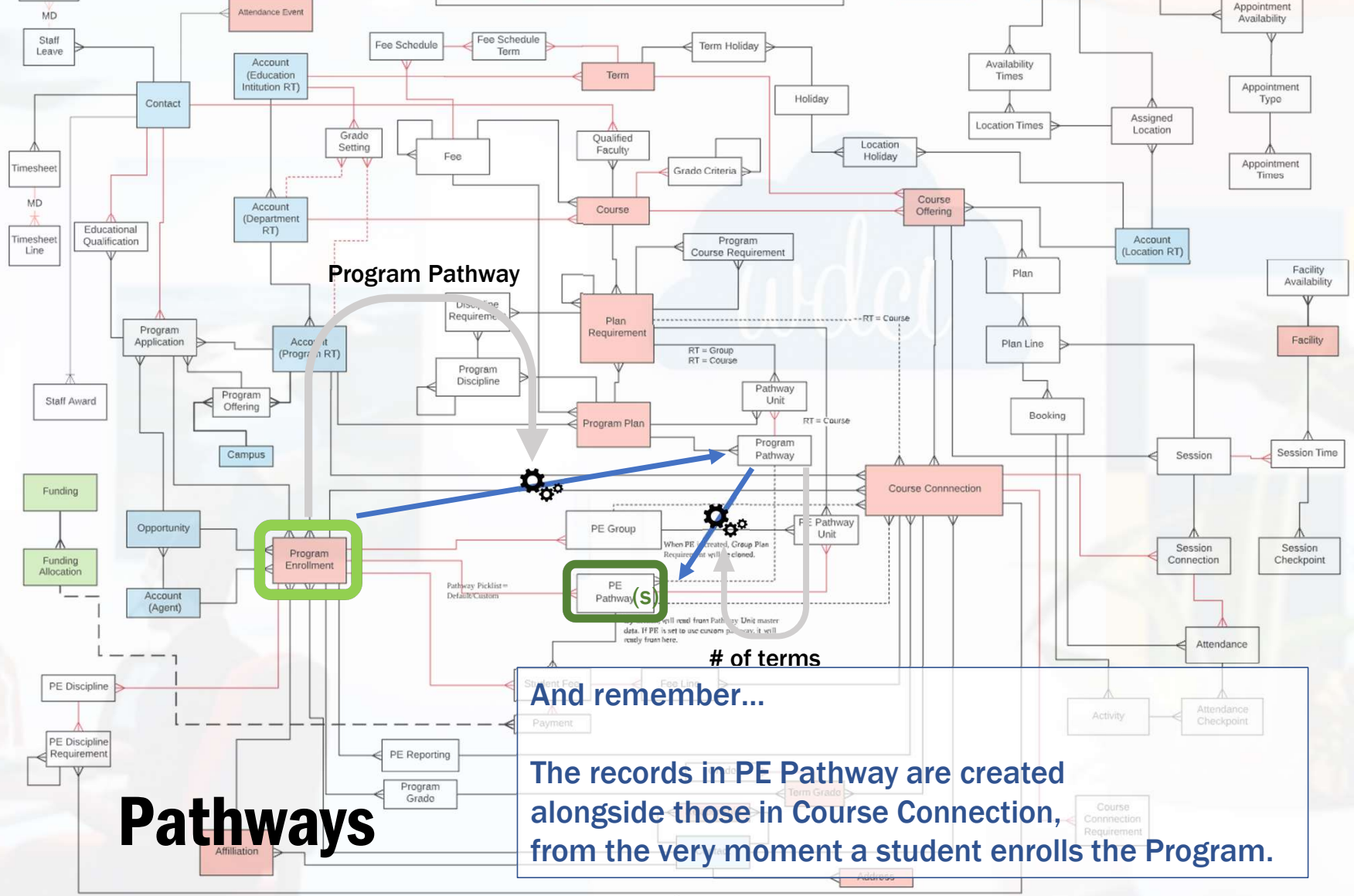
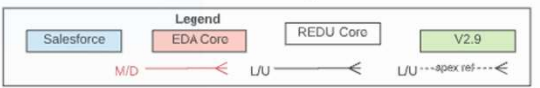

You may want to note that...

the PE automation will create as many PE Pathways as terms are defined in the Program Pathway (i.e. the template)

And remember...

The records in PE Pathway are created alongside those in Course Connection, from the very moment a student enrolls the Program.

Pathways





- With Sofia's Program Enrollment, six PE Pathways were created automatically, since she is a full-time student and the full-time Program Pathway comprises six terms
- Each time the student enrolls courses in a new term, the specific term is linked to the corresponding PE Pathway

**Enrollment PE-0535**

Contact: Sofia Student

Program: Bachelor of Business Information System

Start Date:      GPA: 5.500

Details **Pathways** Unit Enrollments Student Fees PE Disciplines Program Completion Grades

**PE Pathways (6)** New

PE Pathway ID	My Term	Term	Status
PEP-0526	1	Semester 1 2020	Completed
PEP-0527	2	Semester 1 2021	Current
PEP-0528	3	Semester 2 2021	Future
PEP-0529	4		Future
PEP-0530	5		Future
PEP-0531	6		Future

[View All](#)



# Pathways in action

If a student deviates from the recommended pathway, additional PE Pathways are created for each additional term the student takes to progress through their Program

 Enrollment  
**PE-0025**

Contact  
Sarah Smith

Program: Bachelor of Business Information System  
Start Date: 5/03/2018  
GPA: 4.050

Details Pathways Enrollments Student Fees PE Disciplines Program Completion Grades

 PE Pathways (6+) 

New

PE Pathway ID	My Term	Term	Status
PEP-0120	1	Semester 1 2018	Completed
PEP-0121	2	Semester 2 2018	Completed
PEP-0122	3	Semester 1 2019	Completed
PEP-0123	4	Semester 2 2019	Completed
PEP-0124	5	Semester 1 2020	Completed
PEP-0125	6	Semester 2 2020	Completed

[View All](#)



# Pathways in action

With Sofia's Program Enrollment, six PE Pathways were created automatically, since she is a full-time student and the full-time Program Pathway comprises six terms

Enrollments > PE-0025  
**PE Pathways**

8 Items • Sorted by My Term • Updated a few seconds ago

	PE Pathway ID	My Term ↑	Term	Status	Study Mode	Notes	Number of Terms
1	PEP-0120	1	Semester 1 2018	Completed	Full-time	Full time study for the Bachelor of Business Information System	6
2	PEP-0121	2	Semester 2 2018	Completed	Full-time	Full time study for the Bachelor of Business Information System	6
3	PEP-0122	3	Semester 1 2019	Completed	Full-time	Full time study for the Bachelor of Business Information System	6
4	PEP-0123	4	Semester 2 2019	Completed	Full-time	Full time study for the Bachelor of Business Information System	6
5	PEP-0124	5	Semester 1 2020	Completed	Full-time	Full time study for the Bachelor of Business Information System	6
6	PEP-0125	6	Semester 2 2020	Completed	Full-time	Full time study for the Bachelor of Business Information System	6
7	PEP-0402	7	Semester 1 2021	Current			
8	PEP-0403	8	Semester 2 2021	Future			

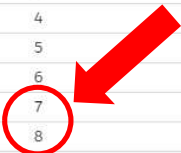

# Pathways in action



*wdci*

Introduction to RIO Education:

# Disciplines



- Program Plans provide a list of requirements to meet
- Pathways provide a (suggested) time sequence to meet them

## **How does this structure accommodate majors and minors?**

Well, it does not... yet. This is what Disciplines are for.







RIO Education Data Model v2.9

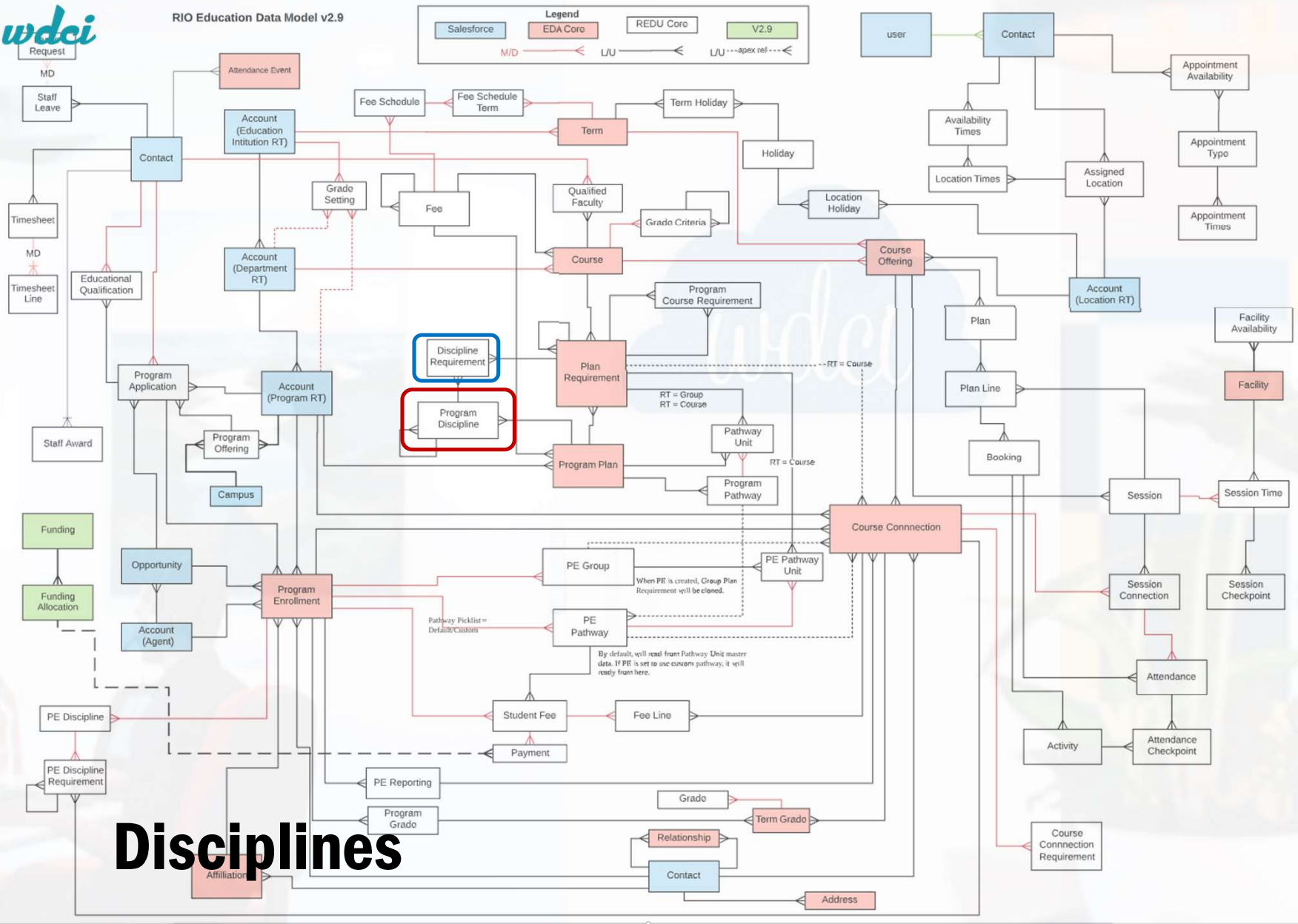

# Disciplines

**A Discipline** is a concept in RIO Education that refers to the **subset of requirements** a student must achieve to complete a Program Plan.

Disciplines limit student obligation toward the Program to a sub-group of requirements

This subset of requirements is defined in the **Discipline Requirement** object



Account **Bachelor of Business Information System**

Account Record Type: Academic Program  
Parent Account: School of Business  
Website

- Details
- Grade Settings
- Program Versions**
- Program Offering



Program Plans (2)

New

Program Plan Name	Start Date	End Date	Status
Bachelor of Business Information System V1	1/01/2018		Current
Bachelor of Business Information System Initial	1/01/2015	31/12/2017	Archived

[View All](#)

# Disciplines in action



Program Plan  
**Bachelor of Business Information System V1**

Start Date      End Date  
1/01/2018



- Details
- Program Structure
- Pathways
- Program Enrollments
- Program Disciplines

Program Disciplines (2)

New

Program Discipline Name	Type	Credits	
Business Analytics	Major	60.000	▼
Project Management	Major	60.000	▼

[View All](#)

# Disciplines in action



Program Disciplines > Business Analytics  
Discipline Requirements

7 Items • Sorted by Parent • Updated a few seconds ago

	<input type="checkbox"/>	Discipline Requirement Name	Record Type	Parent ↑	Plan Requirement	Credits	Requirement	
1	<input type="checkbox"/>	Data Analytics	Group			30.000	Mandatory	▼
2	<input type="checkbox"/>	Communications and Thought	Course	Data Analytics	RIOUNI012018 - COR109		Optional	▼
3	<input type="checkbox"/>	Strategic Management	Course	Data Analytics	RIOUNI022018 - BUS211		Optional	▼
4	<input type="checkbox"/>	Database design	Course	Data Analytics	RIOUNI022018 - ICT211		Mandatory	▼
5	<input type="checkbox"/>	Business Analytics	Course	Data Analytics	RIOUNI022018 - BUS101		Mandatory	▼
6	<input type="checkbox"/>	Introduction to Informatics	Course	Data Analytics	RIOUNI022018 - BUS108		Mandatory	▼
7	<input type="checkbox"/>	Business Analytics 2	Course	Data Analytics	RIOUNI022018 - BUS301		Mandatory	▼

# Disciplines in action





RIO Education Data Model v2.9

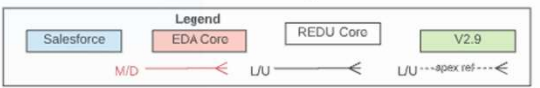

# Summing up...

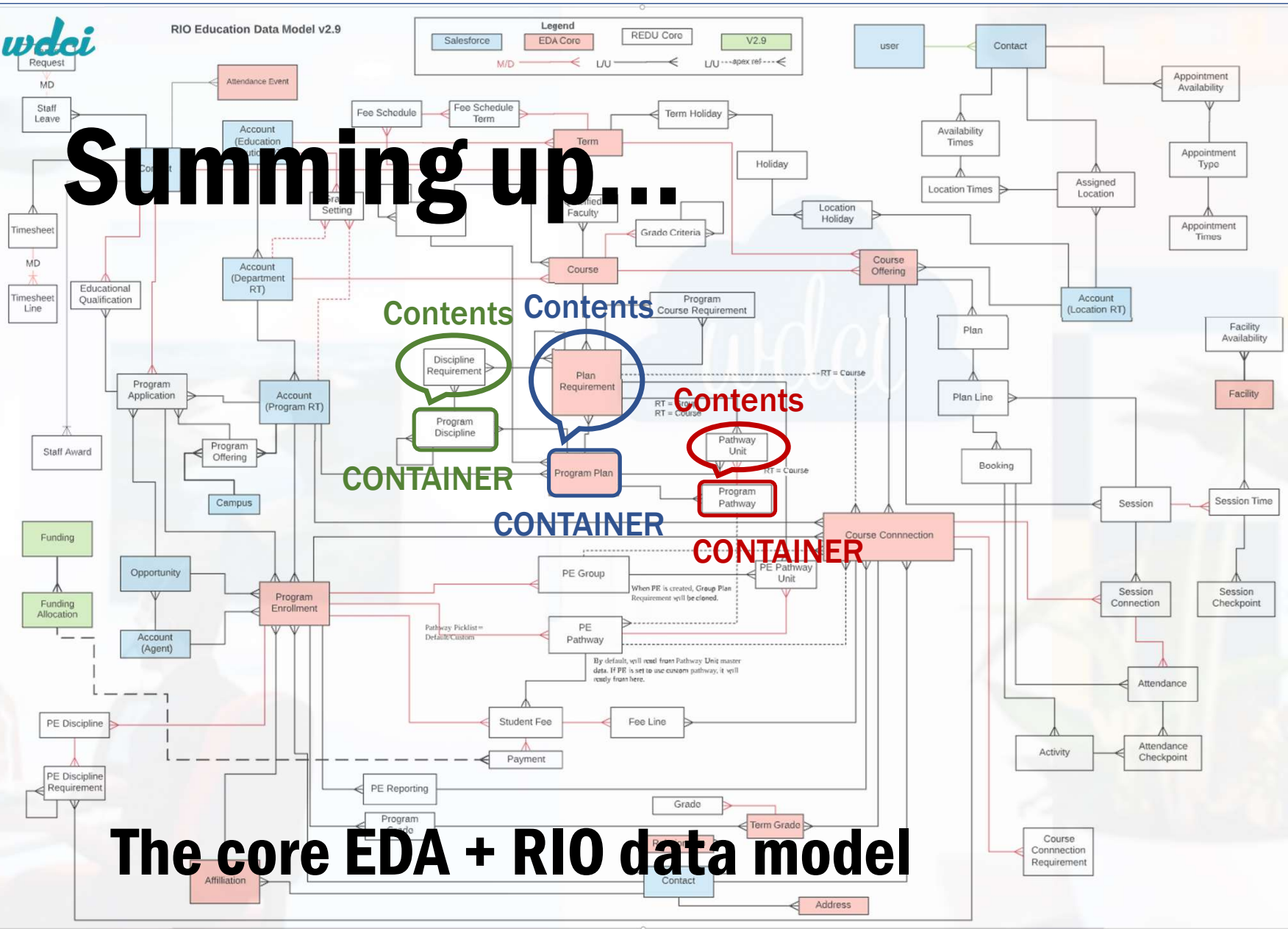

# The core EDA + RIO data model

## Program Plan:

- Provides the list of courses the Program comprises of
- Identifies the course categories as mandatory, optional, etc.

## Program Pathway:

- Provides a time reference to the Plan Requirements

## Program Discipline:

- Allows different student groups to progress through different course subsets (Majors/Minors)





*wdci*

Introduction to RIO Education:

# Program application process



# **The Application process naturally follows the Lead Tracking process**

**Lead tracking is not managed through RIO Education.**





RIO Education Data Model v2.9

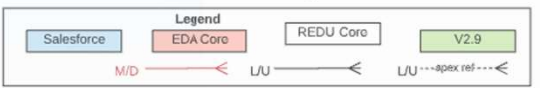

If required, we can support a use case based on EDA standard Application object.

It would just require some customisation work on the existing triggers.

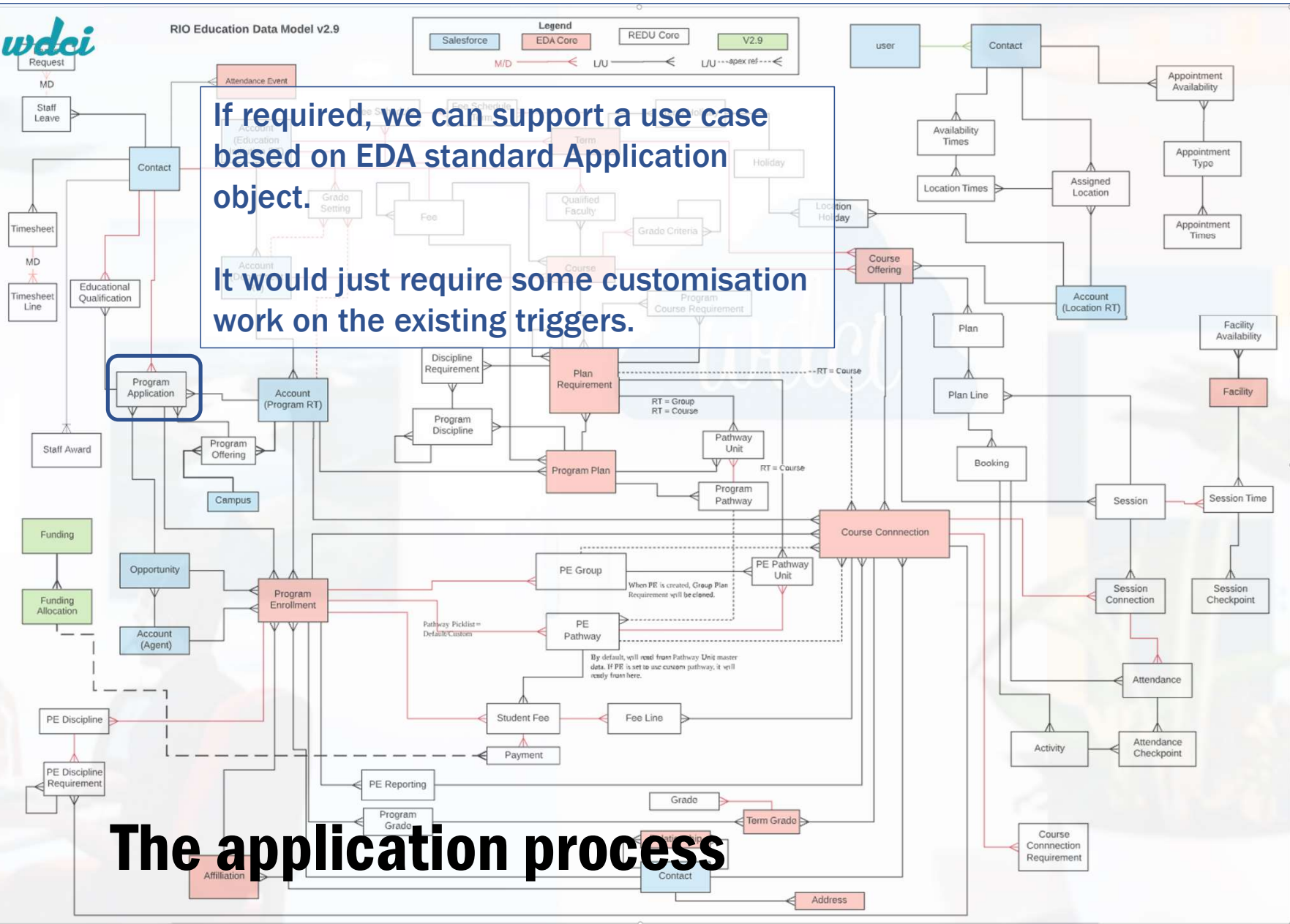

# The application process

RIO does not use EDA's Application object.

It uses the custom object Program Application instead.



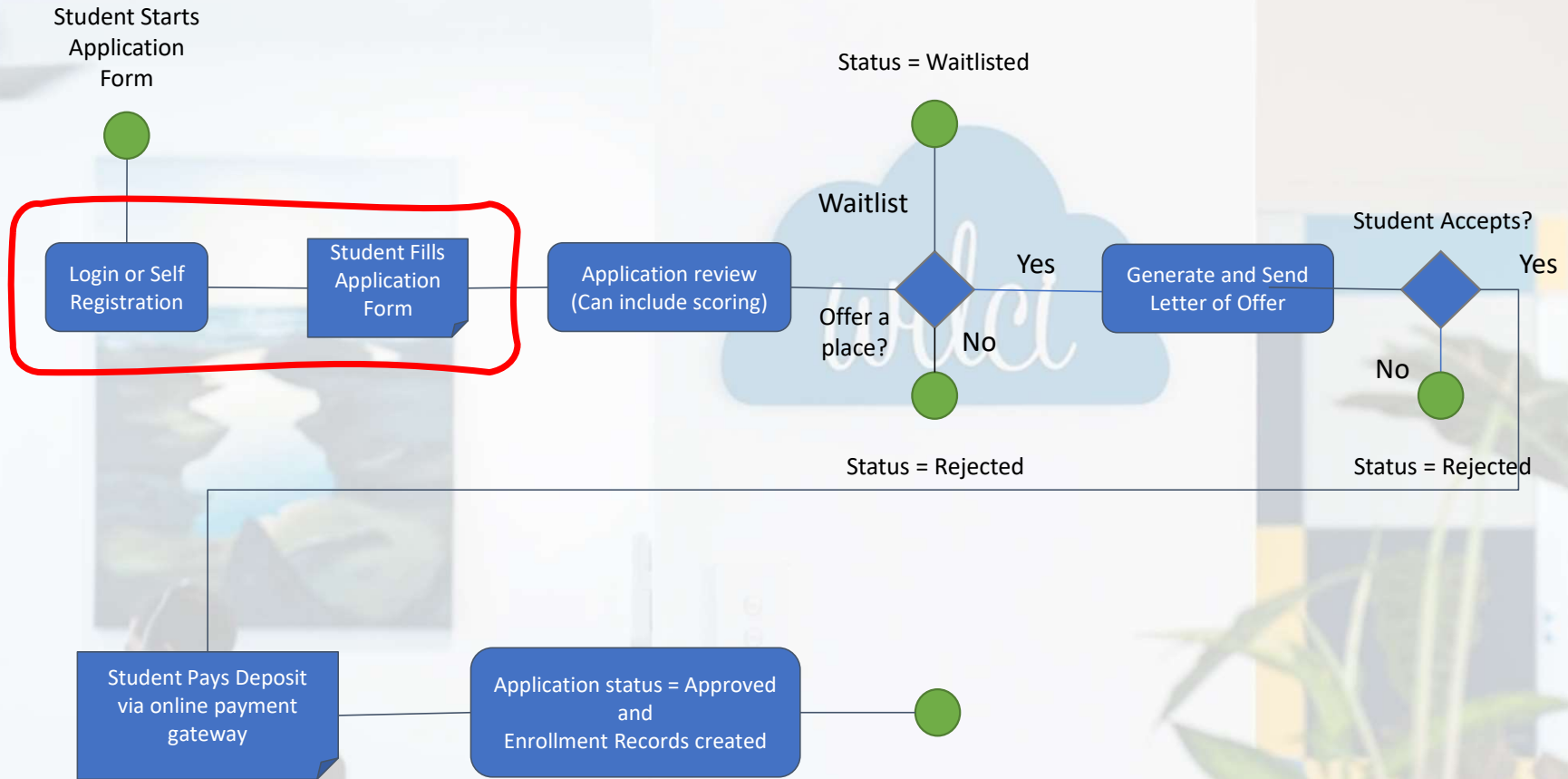

# The application process





Welcome to the RIO Student Portal. This is where your student journey begins. Click on "Apply Now" to become a student or "Learn More" to understand us better!

[Apply Now](#)[Learn More](#)

**There is no need to create a Community user at this stage**

## ABOUT US

RIO was officially launched on 1 January 2016 as a not-for-profit private institution providing quality education. It is established under the RIO Education Foundation and registered under the Australian Private Higher Educational Institutions Act 1996.

Guided by its vision to be a global school of educational excellence, RIO is highly reputed as one of the fastest growing private higher education institutions in the country with phenomenal growth in all aspects of its development since its inception.

RIO has graduated over 58,800 students since its inaugural convocation in 2017 and has made impressive strides in establishing a strong reputation as a comprehensive School with dedication to achieving excellence in teaching and research.

# The application process





## RIO Institution

RIO Institution prepares you for a better future through a comprehensive education that combines both aspects of strategic planning, leadership, and management.

We recommend that applicants log in as Community users though, so their information is protected behind a login

### OUR SCHOOLS

#### School of Arts and Social Sciences

Be inspired to address the key cultural, social and political issues facing the world. You'll embrace new ways to approach complex questions, and get the tools for an exciting career. We also offer a unique perspective through our focus on the Southeast Asian region.

#### School of Business

Join the next generation of leaders and make your mark on the business world.

#### School of Engineering

Are you a creative problem solver? Do you love a challenge? Engineering shapes the world we live in, so take this chance to make your mark.

#### School of Information Technology

Pursue a career in bioinformatics, gaming, networking, artificial intelligence – or one that doesn't yet exist – and you'll be pushing the boundaries of innovation.

#### School of Science

We're pushing the boundaries of innovation and discovery. Help us shape the future.

### YOUR APPLICATION

#### Student Application (Guest)

Contact In... Other Det... Program ... Education... Supportin... Submitted

Please provide your personal details.

\* First Name 

\* Last Name 

\* Email

you@example.com

\* Mobile Phone

\* Community Username

Next



# The application process



## RIO Institution

RIO Institution prepares you for a better future through a comprehensive program that combines both aspects of strategic planning, leadership, and management.

### OUR SCHOOLS

#### School of Arts and Social Sciences

Be inspired to address the key cultural, social and political issues facing the world. You'll embrace new ways to approach complex questions, and get the tools for an exciting career. We also offer a unique perspective through our focus on the Southeast Asian region.

#### School of Business

Join the next generation of leaders and make your mark on the business world.

#### School of Engineering

Are you a creative problem solver? Do you love a challenge? Engineering shapes the world we live in, so take this chance to make your mark.

#### School of Information Technology

Pursue a career in bioinformatics, gaming, networking, artificial intelligence – or one that doesn't yet exist – and you'll be pushing the boundaries of innovation.

#### School of Science

We're pushing the boundaries of innovation and discovery. Help us shape the future.

# The application process

### YOUR APPLICATION

Being logged in also allows to save a draft application

#### Student Application

Contact Info

Other Details

Program Deta...

Educational Q...

Supporting D...

Submitted

Please provide your personal details.

\* First Name 

Sofia

\* Last Name 

Student

\* Email

rio+ss@wdcigroup.net

\* Mobile Phone

+61 456 789 001

\* Community Username

SS

Pause

The downside is:  
Authenticated users  
will require a  
Community licence



Next

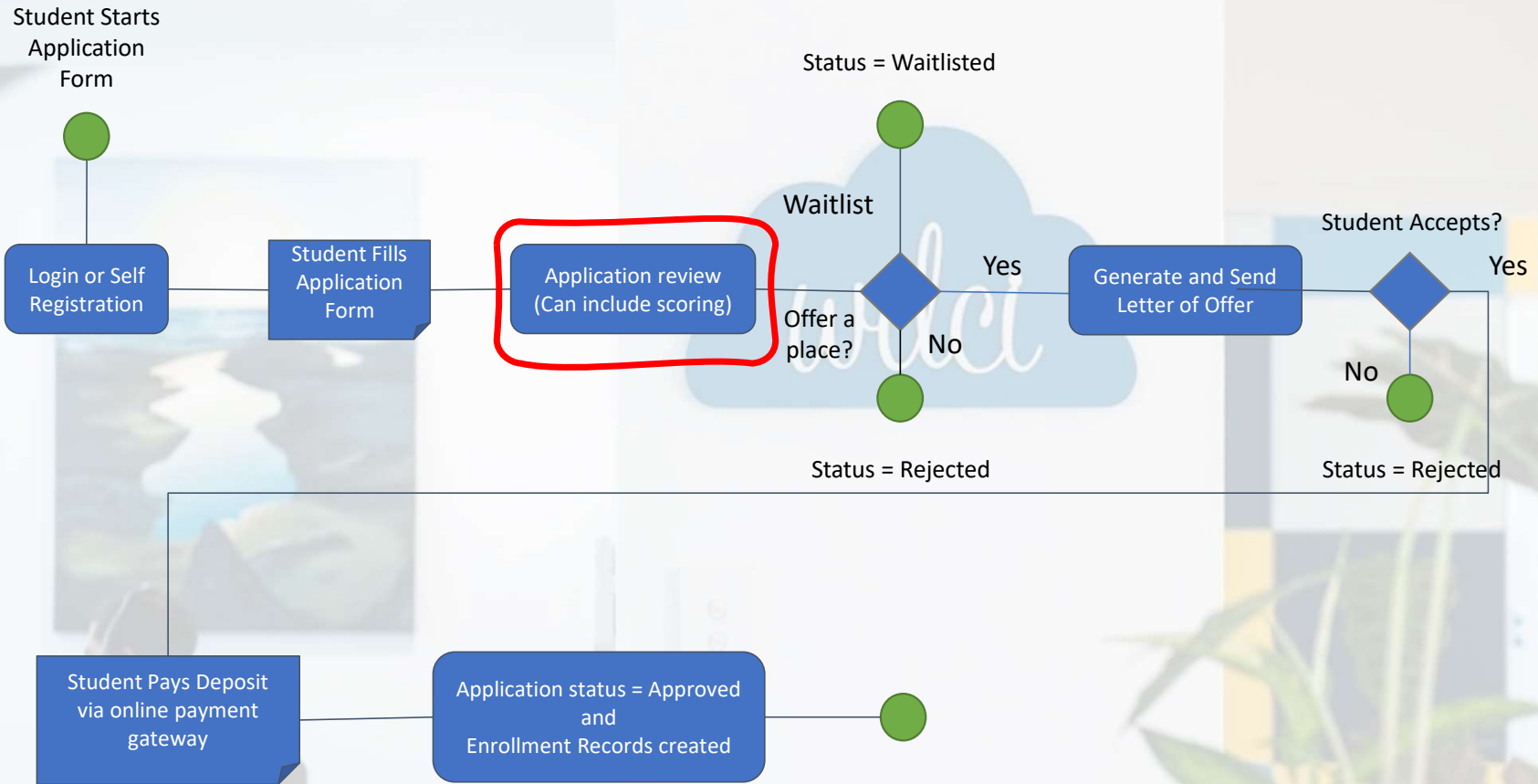

# The application process



Applications Recently Viewed

10 items

RECENT LIST VIEWS

- 2) Submitted
- ✓ Recently Viewed (Pinned list)

ALL OTHER LISTS

- 1) Draft
- 3) Qualified
- 4) Awaiting Documents
- 5) Letter of Offer Sent
- 6A) Accepted
- 6B) Rejected
- 6C) Cancelled
- All

Search this list...

	Start Year	Start Month	Status	Status Date	Last Modified Date	
system	2018	December	Approved	30/03/2021 4:20 PM	30/03/2021 4:20 PM	
system	2021	January	Submitted	13/03/2021 3:09 AM	7/06/2021 1:53 PM	
system	2021	March	Approved	25/03/2021 1:42 PM	25/03/2021 1:42 PM	
	2020	January	Approved	28/01/2021 2:03 PM	28/01/2021 2:03 PM	
	2021	January	Draft	17/03/2021 12:04 AM	22/03/2021 7:22 PM	
	2020	September	Submitted	30/07/2020 11:06 AM	30/07/2020 11:07 AM	
system	2021	September	Awaiting Documents	7/05/2021 4:29 PM	7/05/2021 4:29 PM	
	2019	January	Letter of Offer Sent	18/11/2019 10:52 AM	18/11/2019 10:52 AM	
	2021	January	Submitted	11/02/2021 8:53 AM	11/02/2021 8:54 AM	
system	2021	January	Waitlist	25/03/2021 2:30 PM	25/03/2021 2:30 PM	

# The application process





Draft Submitted Qualified Awaiting Doc... Letter of Offer... Accepted Approved Waitlist Rejected Cancelled

Status: Approved Mark Status as Complete

Details Educational Qualifications History Evaluations

Applicant	Sarah Smith	Status	Approved
Application ID	96	Lead of Business Information System	
Status Date	05/03/2018 14:32:11	Start Month	March
Lead			
Opportunity			
Starting Term			
Default Campus	Campus: Sydney		
Program Offering	B.Bus 2018 Intake		
Payment Information			
Fee Method	Term	Fee Label	
Pay Upfront	No		
Fee Type	Government Funding		
Fee Type Option	FEE-HELP		
Other Information			
Program Entry Criteria	1. Student has at least Diploma Certification on Business Management or Information Systems Engineering 2. Passed all Courses during Diploma.	Evaluation	68.50

Any custom field that we add on to this Application object can subsequently be exposed into the application form in the Community through Salesforce Flow

Related Activity Chatter



Files (3+)

- LetterOfOffer.pdf 06/07/2020 • 70KB • pdf
- Sarah Smith - Diploma of Business 06/07/2020 • 442KB • pdf
- Art 3 23/04/2020 • 6KB • jpg

View All

Evaluations (2)

- EV-00001**  
Evaluated by: Fran Fisher  
Score: 72.00  
Comment: Interesting Candidate
- EV-00002**  
Evaluated by: Felix Ferguson  
Score: 65.00  
Comment: Needs some work but could be successful

View All



# The application process



✓ ✓ ✓ ✓ ✓ ✓ ✓ ✓ ✓ **Approved** Waitlist Rejected Cancelled

Status: Approved ✓ Mark Status as Complete

Details **Educational Qualifications** History Evaluations

**Educational Qualifications (1)** New

Qualification Name	School / Institution	Campus Name	Result / Grade
Diploma of Business	The College of Life	Sydney Campus	3.34

[View All](#)

Related Activity Chatter



**Files (3+)**

- LetterOfOffer.pdf 06/07/2020 • 70KB • pdf
- Sarah Smith - Diploma of Business 06/07/2020 • 442KB • pdf
- Art 3 23/04/2020 • 6KB • jpg

[View All](#)

**Evaluations (2)**

EV-00001  
 Evaluated by: Fran Fisher  
 Score: 72.00  
 Comment: Interesting Candidate

EV-00002  
 Evaluated by: Felix Ferguson  
 Score: 65.00  
 Comment: Needs some work but could be successful - Love the frogs

[View All](#)

**Educational Qualification**  
Diploma of Business

School / Institution	Campus Name	Study Mode	Start Date	Completion Date	Completion Status
The College of Life	Sydney Campus	Online	03/2014	05/2015	Completed

**Details** Related Documents

Qualification Name: Diploma of Business

Contact: Sarah Smith

Program Application: PA-00098

**Study Information**

School / Institution	Campus Name	Study Mode	Start Date	Completion Date	Completion Status	Result / Grade
The College of Life	Sydney Campus	Online	03/2014	05/2015	Completed	3.34

Details **Related Documents**

**Files (1)**

Sarah Smith - Diploma of Business 06/07/2020 • 442KB • pdf

# The application process



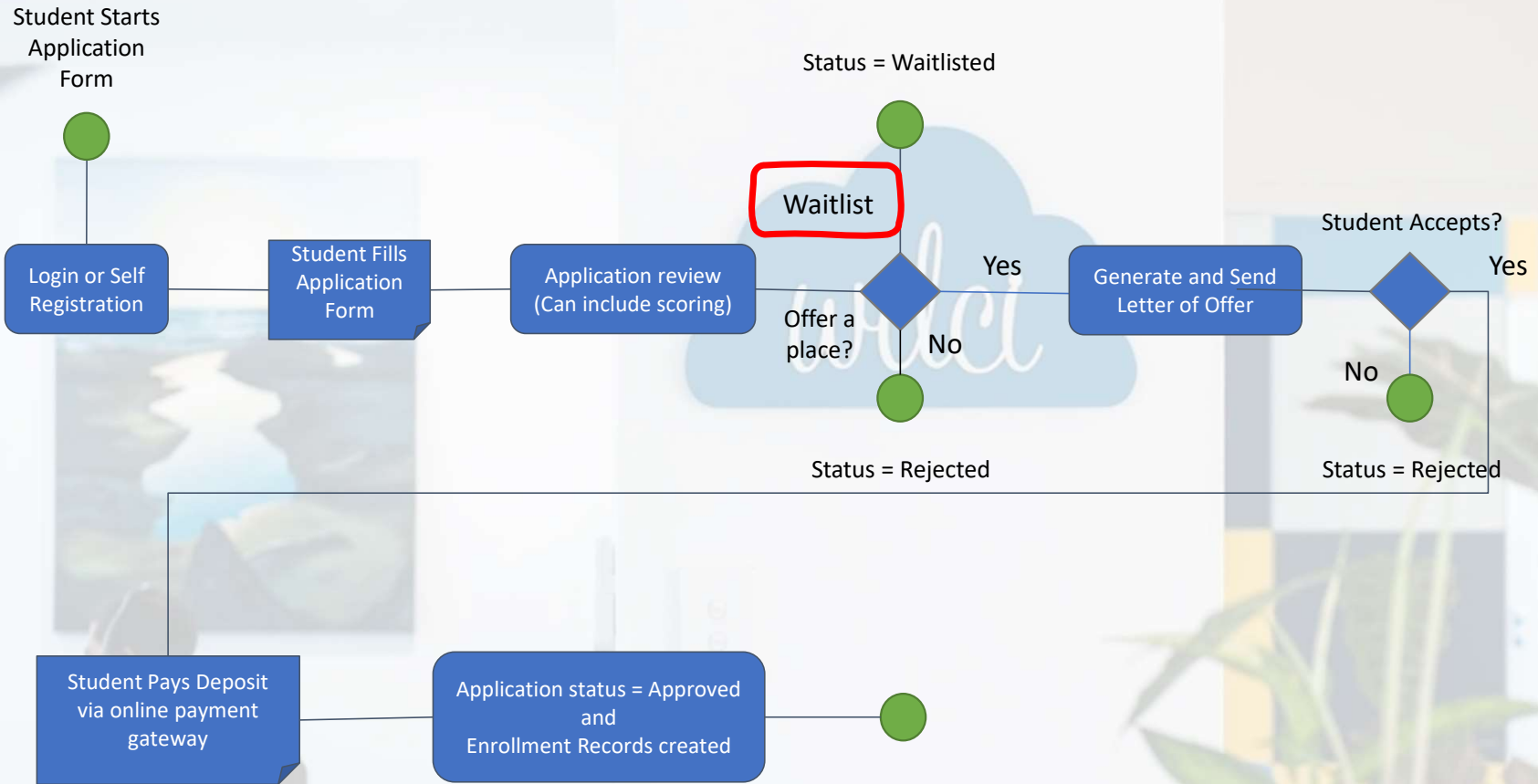

# The application process



> Draft Submitted Qualified Awaiting Doc... Letter of Offer... Accepted **Approved** Waitlist Rejected Cancelled

Status: Approved  Mark Status as Complete

Details	Educational Qualifications	History	Evaluations
Applicant	Sarah Smith	Status	Approved
Application ID	PA-00098	Program	Bachelor of Business Information System
Status Date	25/03/2021 1:42 PM	Study Mode	Full-time
Lead		Start Month	March
Opportunity		Start Year	2021
Starting Term	Semester 1 2018		
Default Campus	Campus: Sydney		
Program Offering	B.Bus 2018 Intake		
Payment Information			
Fee Method	Term	Fee Label	
Pay Upfront	No		
Fee Type	Government Funding		
Fee Type Option	FEE-HELP		
Other Information			
Program Entry Criteria	1. Student has at least Diploma Certification on Business Management or Information Systems Engineering 2. Passed all Courses during Diploma.	Evaluation	68.50

Related Activity Chatter



Files (3+)

- LetterOfOffer.pdf 06/07/2020 • 70KB • pdf
- Sarah Smith - Diploma of Business 06/07/2020 • 442KB • pdf
- Art 3 23/04/2020 • 6KB • jpg

Evaluations (2)

- EV-00001  
Evaluated by: Fran Fisher  
Score: 72.00  
Comment: Interesting Candidate
- EV-00002  
Evaluated by: Felix Ferguson  
Score: 65.00  
Comment: Needs some work but could be successful



# The application process

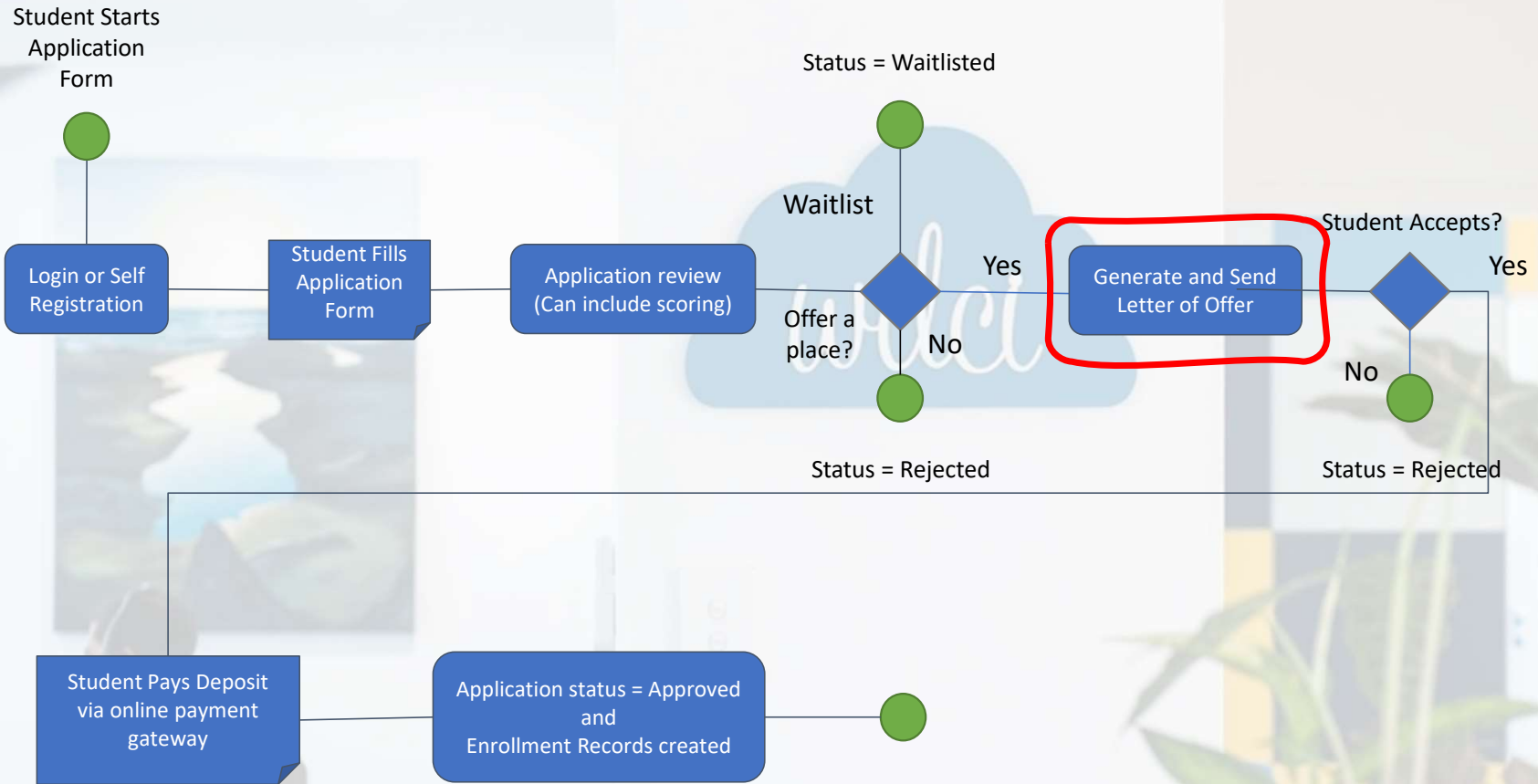

# The application process



Application  
**Sarah Smith**

> **Draft** Submitted Qualified Awaiting Doc... Letter of Offer... Accepted **Approved** Waitlist Rejected

Status: **Approved**

**Details** Educational Qualifications History Evaluations

Applicant	Sarah Smith	Status	Approved
Application ID	PA-00098	Program	Bachelor of Business Information System
Status Date	25/03/2021 1:42 PM	Study Mode	Full-time
Lead		Start Month	March
Opportunity		Start Year	2021
Starting Term	Semester 1 2018		
Default Campus	Campus: Sydney		
Program Offering	B.Bus 2018 Intake		
<b>Payment Information</b>			
Fee Method	Term	Fee Label	
Pay Upfront	No		
Fee Type	Government Funding		
Fee Type Option	FEE-HELP		
<b>Other Information</b>			
Program Entry Criteria	1. Student has at least Diploma Certification on Business Management or Information Systems Engineering 2. Passed all Courses during Diploma.	Evaluation	68.50



Generate Letter of Offer

Edit Clone

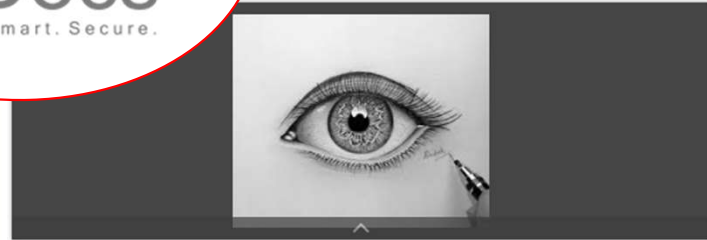

**Files (3+)**

- LetterOfOffer.pdf  
06/07/2020 • 70KB • pdf
- Sarah Smith - Diploma of Business  
06/07/2020 • 442KB • pdf
- Art 3  
23/04/2020 • 6KB • jpg

[View All](#)

**Evaluations (2)**

- EV-00001**  
Evaluated by: Fran Fisher  
Score: 72.00  
Comment: Interesting Candidate
- EV-00002**  
Evaluated by: Felix Ferguson  
Score: 65.00  
Comment: Needs some work but could be successful

[View All](#)



# The application process



RIO University

15 Bingera Terrace, Caloundra, 4551  
Tel +61 288 889 999 Fax  
Web [www.riouniversity.edu.au](http://www.riouniversity.edu.au)



**Letter of Offer**

Sarah Smith  
Student ID: HE23577  
15  
Bingera Terrace  
Caloundra  
QLD 4551  
Email: [rio+sarahsmith@wdcigroup.net](mailto:rio+sarahsmith@wdcigroup.net)

06 July 2020

Dear Sarah,

Thank you for your recent application to enrol at RIO Institution. Based on the information and the documentation you have provided, we would like to offer you a place to study with us as detailed below and in this document.

The information in this Letter summarises the program/s of study, including important dates and estimated fees.

Program Name	Bachelor of Business Information System
Program Code	RIOUNI02
Duration	3 years
Study location	RIO Institution Main Campus
Program Start	December 2018
Tuition Fee	\$3500.00
Fees payable to secure this Offer	\$500.00 - Due at time of Application Lodgement

*\* Note: Fees and charges may increase; the fees on this offer are correct at the date of this letter, and are subject to increase.*

In order to secure your position, you must read and understand this document in full and then:

1. Read and understand the [RIO University Terms and Conditions](#)

The application process

RIO University

15 Bingera Terrace, Caloundra, 4551  
Tel +61 288 889 999 Fax  
Web [www.riouniversity.edu.au](http://www.riouniversity.edu.au)



2. Read and understand the [RIO University Student Code of Conduct](#)
3. Make your payment of the amount owing as per the "Fees payable to secure this Offer" above, via the [RIO University payment gateway](#), with reference to your Student ID **HE23577**
4. Complete your [Acceptance of Offer](#) with attached copies of any supporting documents required to meet the "Conditions of this Offer" itemised above.

Upon receipt of your payment, Acceptance of Offer, and Supporting Documents, your application will be reviewed.

If you are successful with your application to RIO Institution, you will receive a formal Letter of Acceptance detailing your confirmation.

If you have any questions, please contact:

Mary Rio  
Administration Officer  
Phone: +61 (0)7 5111 2222  
Email: [offerhelp@rioinstitution.edu.au](mailto:offerhelp@rioinstitution.edu.au)

Kind Regards,  
*Barry Rio*  
Chief Operations Officer  
RIO Institution



Application Sarah Smith

Status: Approved

Approved Waitlist Rejected Cancelled

Details Educational Qualifications History Evaluations

Applicant	Sarah Smith	Status	Approved
Application ID	PA-00098	Program	Bachelor of Business Information System
Status Date	25/03/2021 1:42 PM	Study Mode	Full-time
Lead		Start Month	March
Opportunity		Start Year	2021
Starting Term	Semester 1 2018		
Default Campus	Campus: Sydney		
Program Offering	B.Bus 2018 Intake		
Payment Information			
Fee Method	Term	Fee Label	
Pay Upfront	No		
Fee Type	Government Funding		
Fee Type Option	FEE-HELP		
Other Information			

Link from within the applicant can accept or reject the offer

Activity

New Task New Event Log a Call Email

Filters: All time • All activities • All types

Upcoming & Overdue

No next steps. To get things moving, add a task or set up a meeting.

July • 2020 Last Year

Letter of Offer noreply@wdcigroup.net sent an email to Sarah Smith 6:21 PM | 06/07/2020

From Address noreply@wdcigroup.net To Address Sarah Smith

Text Body Dear Student, I am pleased to advise you that you have been accepted into the Bachelor of Business Information System which commences on December 2018. Kindly click here to Accept/Reject the offer: https://rio-edu.force.com/rioinstitution/s/program-application/a0Y7F000005XdhT

Regards, Admin

Reply All Reply Forward

Email template

# The application process





Status: Approved Mark Status as Complete

Applicant	Sarah Smith	Status	Approved
Application ID	PA-00098	Program	Bachelor of Business Information System
Status Date	25/03/2021 1:42 PM	Study Mode	Full-time
Lead		Start Month	March
Opportunity		Start Year	2021
Starting Term	Semester 1 2018		
Default Campus	Campus: Sydney		
Program Offering	B.Bus 2018 Intake		
<b>Payment Information</b>			
Fee Method	Term	Fee Label	
Pay Upfront	No		
Fee Type	Government Funding		
Fee Type Option	FEE-HELP		
<b>Other Information</b>			
Program Entry Criteria	1. Student has at least Diploma Certification on Business Management or Information Systems Engineering 2. Passed all Courses during Diploma.	Evaluation	68.50
Prerequisites Met	<input type="checkbox"/>	Evaluation Count	2
Created By	Adam Administrator, 25/03/2021 1:42 PM	Last Modified By	Adam Administrator, 25/03/2021 1:42 PM

**Related** Activity Chatter

**Files (3+)**

- LetterOfOffer.pdf 06/07/2020 • 70KB • pdf
- Sarah Smith - Diploma of Business 06/07/2020 • 442KB • pdf
- Art 3 23/04/2020 • 6KB • jpg

[View All](#)

**Evaluations (2)**

- EV-000001  
Evaluated by: Fran Fisher  
Score: 72.00  
Comment: Interesting Candidate
- EV-000002  
Evaluated by: Felix Ferguson  
Score: 65.00  
Comment: Needs some work but could be successful - Love the frogs



# The application process



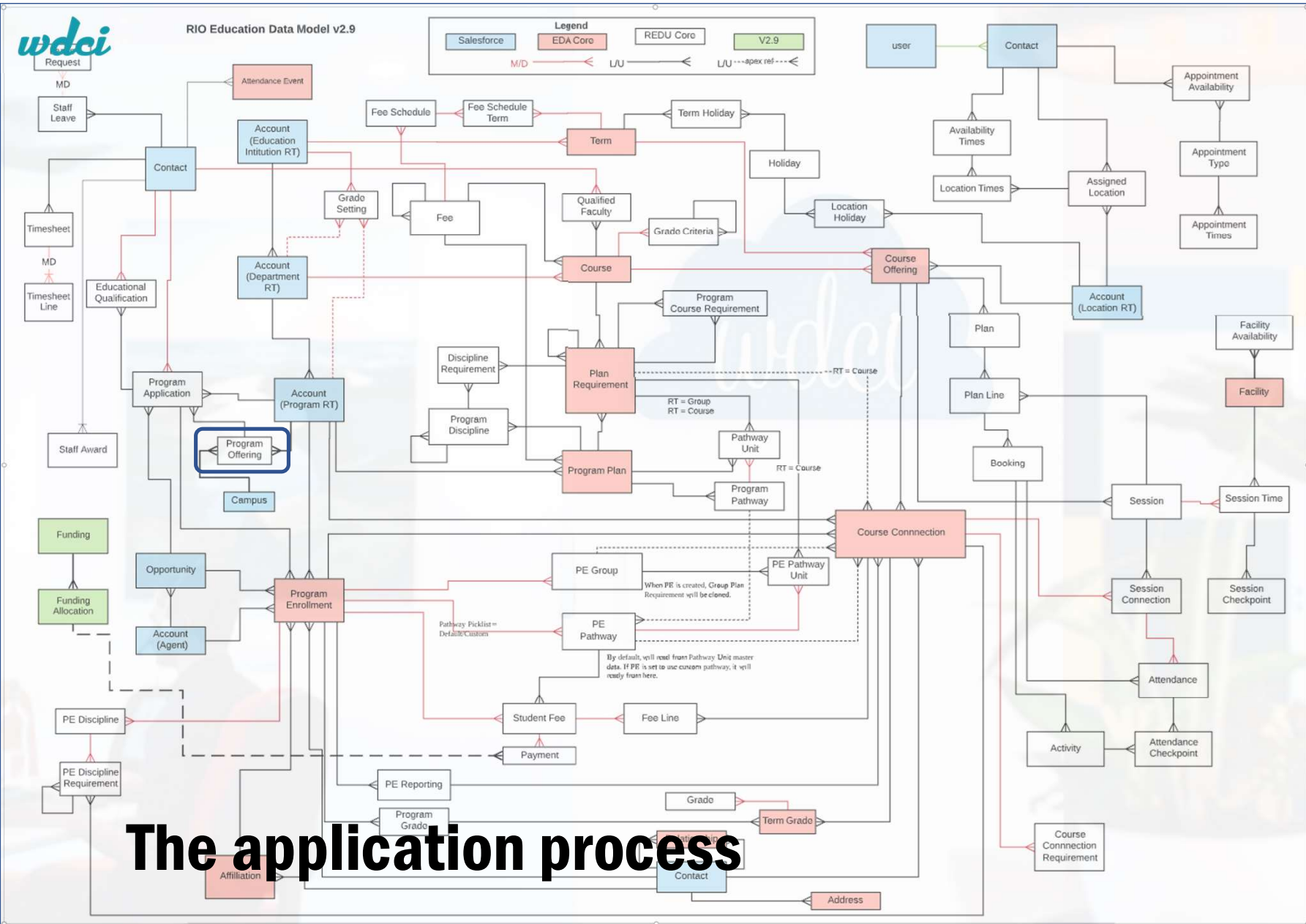

Student intakes are managed in the Program Offering object.

Program Offering is only relevant to the Application process.





Program Offering  
**Bachelor of Business Information System**

Campus  
Campus: Sydney

**Details** All Applications Approved Applications Waitlist

Program Offering ID	B.Bus 2018 Intake	Owner	Adam Administrator
Campus	Campus: Sydney	Term	Semester 1 2018
Program	Bachelor of Business Information System	Places Offered	50
Approved Applications	2		
Waitlisted Applications	1		
Rejected Applications	0		
Total Applications	3		
Created By	Adam Administrator, 4/02/2021 7:23 AM	Last Modified By	Adam Administrator, 30/03/2021 4:20 PM

Application  
**Sarah Smith**

Status: Approved

**Details** Educational Qualifications History

Applicant	Sarah Smith
Application ID	PA-00098
Status Date	25/03/2021 1:42 PM
Lead	
Opportunity	
Starting Term	Semester 1 2018
Default Campus	Campus: Sydney
Program Offering	B.Bus 2018 Intake

Payment Information

Fee Method	Term
Pay Upfront	No
Fee Type	Government Funding
Fee Type Option	FEE-HELP

Other Information

Program Entry Criteria	1. Student has at least Diploma Certification on Business Information Systems Engineering 2. Passed all Courses during Diploma.
Prerequisites Met	<input type="checkbox"/>
Created By	Adam Administrator, 25/03/2021 1:42 PM

Program Offering  
**Bachelor of Business Information System**

Campus  
Campus: Sydney

**All Applications** Approved Applications Waitlist

Program Applications (3)  
3 Items • Updated a few seconds ago

	Application ID	Applicant	Status	Status Date	Evaluation	Study Mode	Starting Term
1	PA-00015	Sofia Student	Approved	30/03/2021 4:20 PM	89.00	Full-time	Semester 1 2021
2	PA-00098	Sarah Smith	Approved	25/03/2021 1:42 PM	68.50	Full-time	Semester 1 2018
3	PA-00271	Gemma López	Waitlist	25/03/2021 2:30 PM	56.00	Full-time	Semester 1 2018

We can use a trigger to enroll approved applicants until reaching the # of places offered

# The application process





**SETUP**  
**Flows**

Flow Definitions  
**All Flows**

12 items • Sorted by Flow Label • Filtered by All flow

Flow Label ↑	Flow Type	Autolaunched	Screen Flow	Managed	Owner
Accommodation Application	Screen Flow	<input type="checkbox"/>	<input type="checkbox"/>	Unmanaged	
Application Form - US Resident	Screen Flow	<input type="checkbox"/>	<input type="checkbox"/>	Unmanaged	
Appointment Status email flow	Screen Flow	<input type="checkbox"/>	<input type="checkbox"/>	Unmanaged	
Co-curricular Log	Screen Flow	<input type="checkbox"/>	<input type="checkbox"/>	Unmanaged	
Demo-Course Transfer	Screen Flow	<input type="checkbox"/>	<input type="checkbox"/>	Unmanaged	
Funding Application	Screen Flow	<input type="checkbox"/>	<input checked="" type="checkbox"/>	Managed-Installed	RIO Education
New Contact Attendance flow	Autolaunched Flow	<input checked="" type="checkbox"/>	<input type="checkbox"/>	Unmanaged	
<b>Program Application</b>	Screen Flow	<input checked="" type="checkbox"/>	<input checked="" type="checkbox"/>	Managed-Installed	RIO Education
Program Application Acceptance	Screen Flow	<input checked="" type="checkbox"/>	<input type="checkbox"/>	Unmanaged	
<b>Program Application Acceptance</b>	Screen Flow	<input checked="" type="checkbox"/>	<input checked="" type="checkbox"/>	Managed-Installed	RIO Education
Student Application	Screen Flow	<input checked="" type="checkbox"/>	<input type="checkbox"/>	Unmanaged	
Student Application (Guest)	Screen Flow	<input checked="" type="checkbox"/>	<input type="checkbox"/>	Unmanaged	

**YOUR APPLICATION**

Student Application

**Contact Info** Other Details Program Deta... Educational

Please provide your personal details.

\* First Name Sarah

\* Last Name Smith

\* Email rio+sarahsmith@wdcigroup.net

\* Mobile Phone 61410616600

\* Community Username s.smith

Pause

**Letter of Offer**

noreply@wdcigroup.net sent an email to Sarah Smith 6:21 PM | 06/21/2020

From Address noreply@wdcigroup.net To Address Sarah Smith

Text Body Dear Student,

I am pleased to advise you that you have been accepted into the Bachelor of Business Information System which commences on December 2018.

Kindly click here to Accept/Reject the offer: <https://rio-edu.force.com/rioinstitution/s/program-application/a0Y7F000005XdhT>

Regards, Admin

Reply All Reply Forward

June • 2020

Call You logged a call

No more past activities to load.

# The application process



# Program Application Flow:

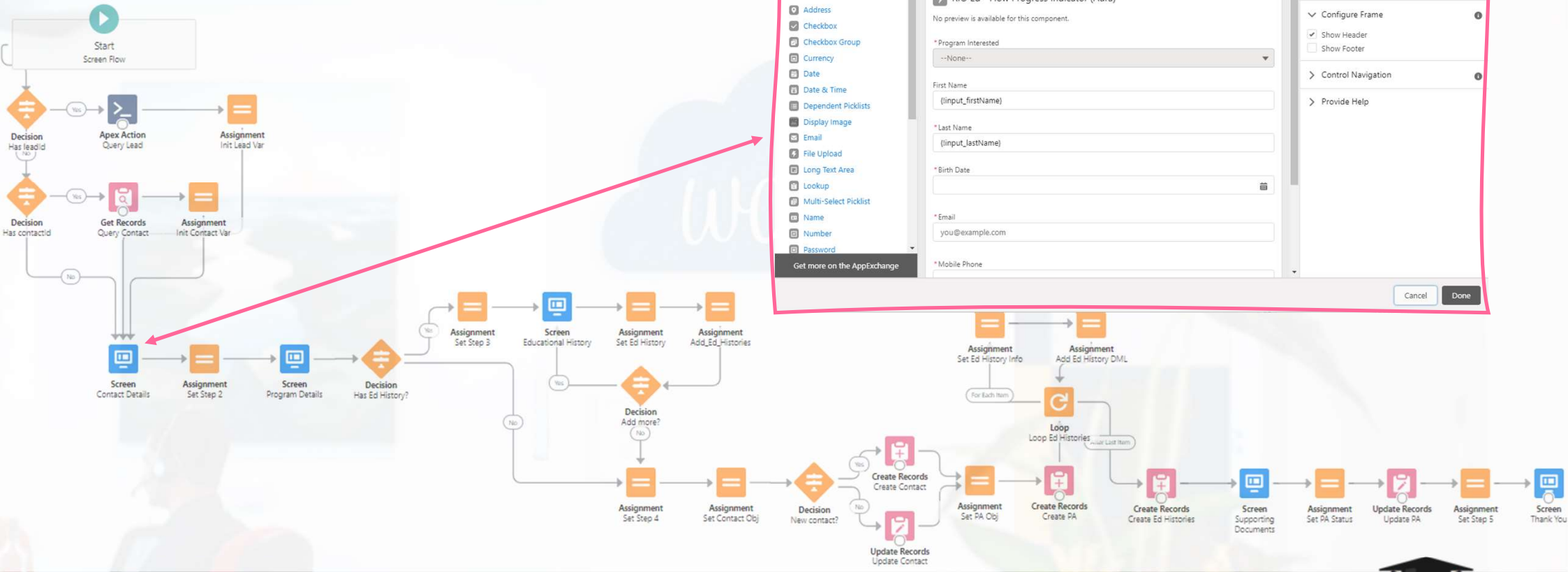

Edit Screen

Components Fields (Beta)

Search components... Q

- Input (23)
- Address
- Checkbox
- Checkbox Group
- Currency
- Date
- Date & Time
- Dependent Picklists
- Display Image
- Email
- File Upload
- Long Text Area
- Lookup
- Multi-Select Picklist
- Name
- Number
- Password

Get more on the AppExchange

**Program Application**

RIO Ed - Flow Progress Indicator (Aura)

No preview is available for this component.

\* Program Interested  
--None--

First Name  
(input\_firstName)

\* Last Name  
(input\_lastName)

\* Birth Date

\* Email  
you@example.com

\* Mobile Phone

Screen Properties

Contact Details  
(Contact\_Details\_Screen)

Configure Frame

- Show Header
- Show Footer

Control Navigation

Provide Help

Cancel Done

More about Flow: [https://trailhead.salesforce.com/en/content/learn/modules/business\\_process\\_automation/flow](https://trailhead.salesforce.com/en/content/learn/modules/business_process_automation/flow)

# The application process



# Once set up, Flows can be deployed in the Student Community:



- Feature Settings
  - Digital Experiences
    - All Sites**
    - Pages
    - Settings
    - Templates
    - Themes

## SETUP All Sites

### Digital Experiences

[Visit our Trailblazer CommunityHelp for this Page](#)

The list shows Experience Cloud sites in your org. Clicking on the URL takes you directly to the site. If you're not a member, the URL isn't linked.  
Maximum number of sites (including active, inactive, and preview): 100

All Sites					New
Action		Name	Description	URL	Status
Workspaces	Builder	RIO Community	For student and faculty.	<a href="https://rio-edu.force.com/portal">https://rio-edu.force.com/portal</a>	Active
Workspaces	Builder	RIO Institution	RIO Institution community is used for RIO education demo. Please contact Walter or Jimmi if there are any changes required	<a href="https://rio-edu.force.com/rioinstitution">https://rio-edu.force.com/rioinstitution</a>	Active
Workspaces	Builder	RIO Institution (Data Validation)		<a href="https://rio-edu.force.com/rioinstitutiondatavalidation">https://rio-edu.force.com/rioinstitutiondatavalidation</a>	Active
Workspaces	Builder	Faculty Community		<a href="https://rio-edu.force.com/faculty">https://rio-edu.force.com/faculty</a>	Inactive
Workspaces	Builder	RIO Institution Community (Obsolete)	RIO Institution community is used for RIO education demo. Please contact Walter or Jimmi if there are any changes required	<a href="https://rio-edu.force.com/rioinstitutionobsolete">https://rio-edu.force.com/rioinstitutionobsolete</a>	Inactive
Workspaces	Builder	Spanish Community		<a href="https://rio-edu.force.com/spanish">https://rio-edu.force.com/spanish</a>	Inactive
Workspaces	Builder	RIO Community (3)		<a href="https://rio-edu.force.com/riocommunity3">https://rio-edu.force.com/riocommunity3</a>	Preview
Workspaces	Builder	RIO Community (obsolete)		<a href="https://rio-edu.force.com">https://rio-edu.force.com</a>	Preview

Didn't find what you're looking for?  
Try using Global Search.

# The application process



# Once set up, Flows can be deployed in the Student Community:

The screenshot shows a web application builder interface. On the left, a 'Components' sidebar lists various elements, with 'Flow' highlighted in a red box. The main canvas displays a page layout for 'RIO Institution'. A section titled 'YOUR APPLICATION' is highlighted with a red box and contains a 'Flow Component: Student Application' placeholder. On the right, a 'Flow' configuration panel is visible, showing settings for the 'Student Application' flow, including a layout of 'One Column' and an input field for 'Input\_Contact\_Id'.

## The application process





## Existing RIO Components that may become useful for an implementation

- **Self Registration component:**
  - We have some custom components built for completed projects.
- **Referee request component:**
  - The Applicant can name a Referee, and have RIO email them with a link to upload a reference directly.
- **ePortfolio:**
  - Great for Art schools who need to upload images with details about art portfolios.
- **File upload utility:**
  - We have some utils to allow this for guest users.

## The application process





Student Starts Application Form

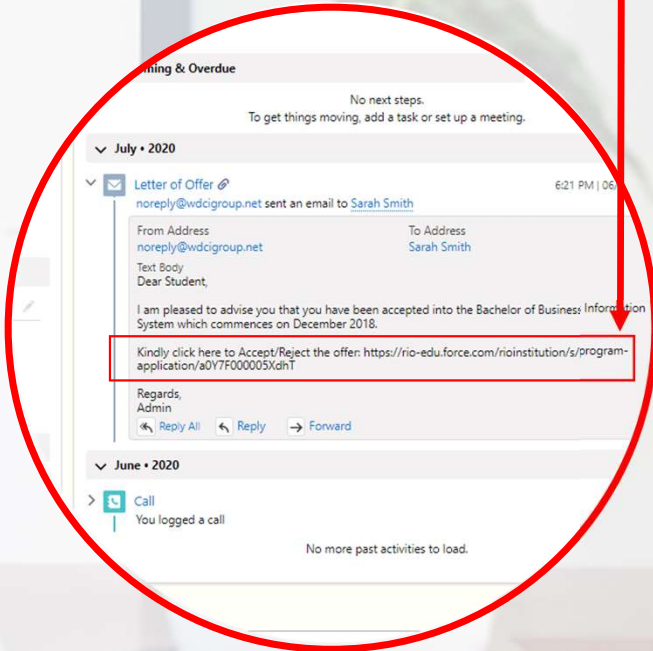
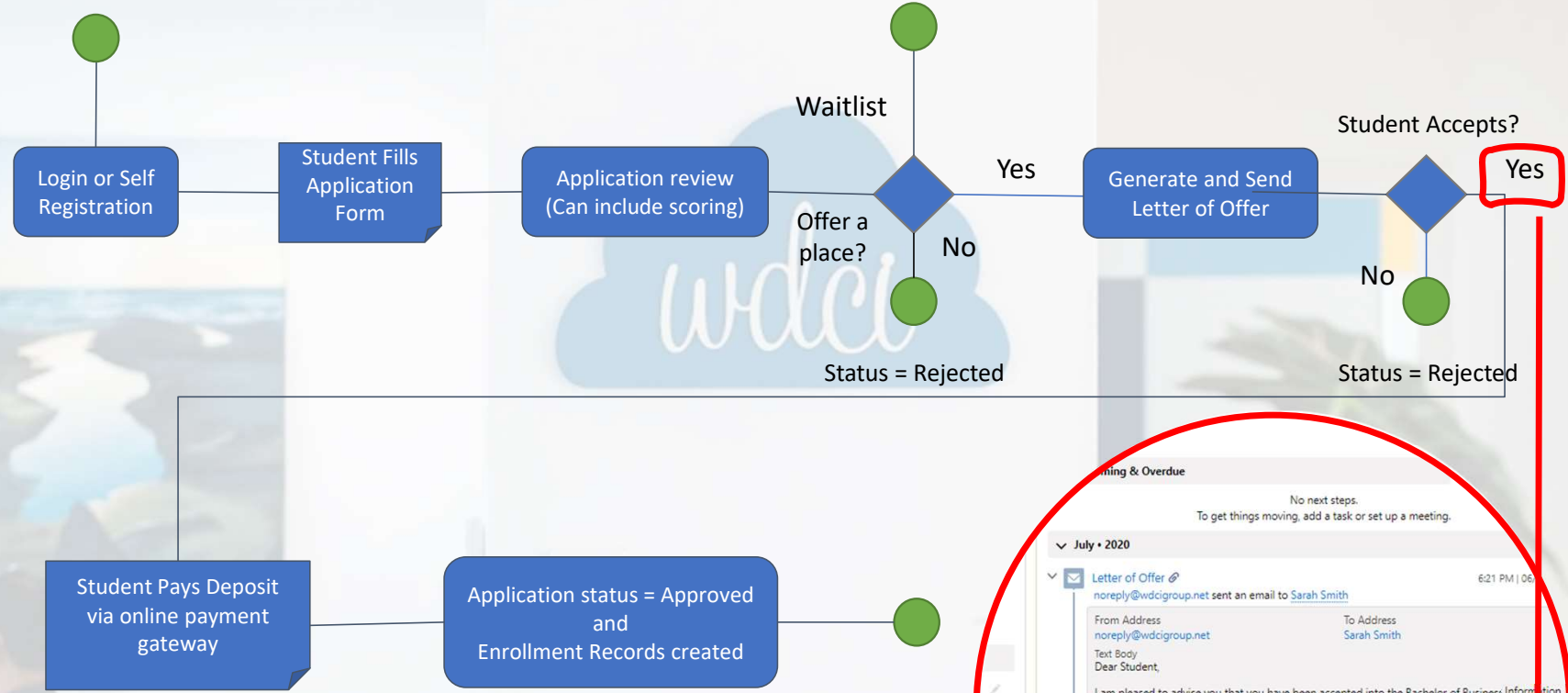

# The application process

## Triggers and Automations on Acceptance

When an application is accepted we have a number of automations that can be used. These are currently set in triggers deployed with RIO against our Program Application object. If you chose to use the EDA application object these will need to be cloned and set against that object.

- Set a Student ID;
- Set an Academic Email address/username to replace the applicant's personal ones;
- Create a community login, and email password set function to students;  
(If they were not already a user from the application flow)
- Create the Program Enrollment and all the related records.  
*(It is important that this step runs as all the enrollments and completion rely on the data and data structures created)*



If you decide to use the EDA 'Application' objects, you must recreate these triggers against that object!



## The application process



RIO Education Data Model v2.9

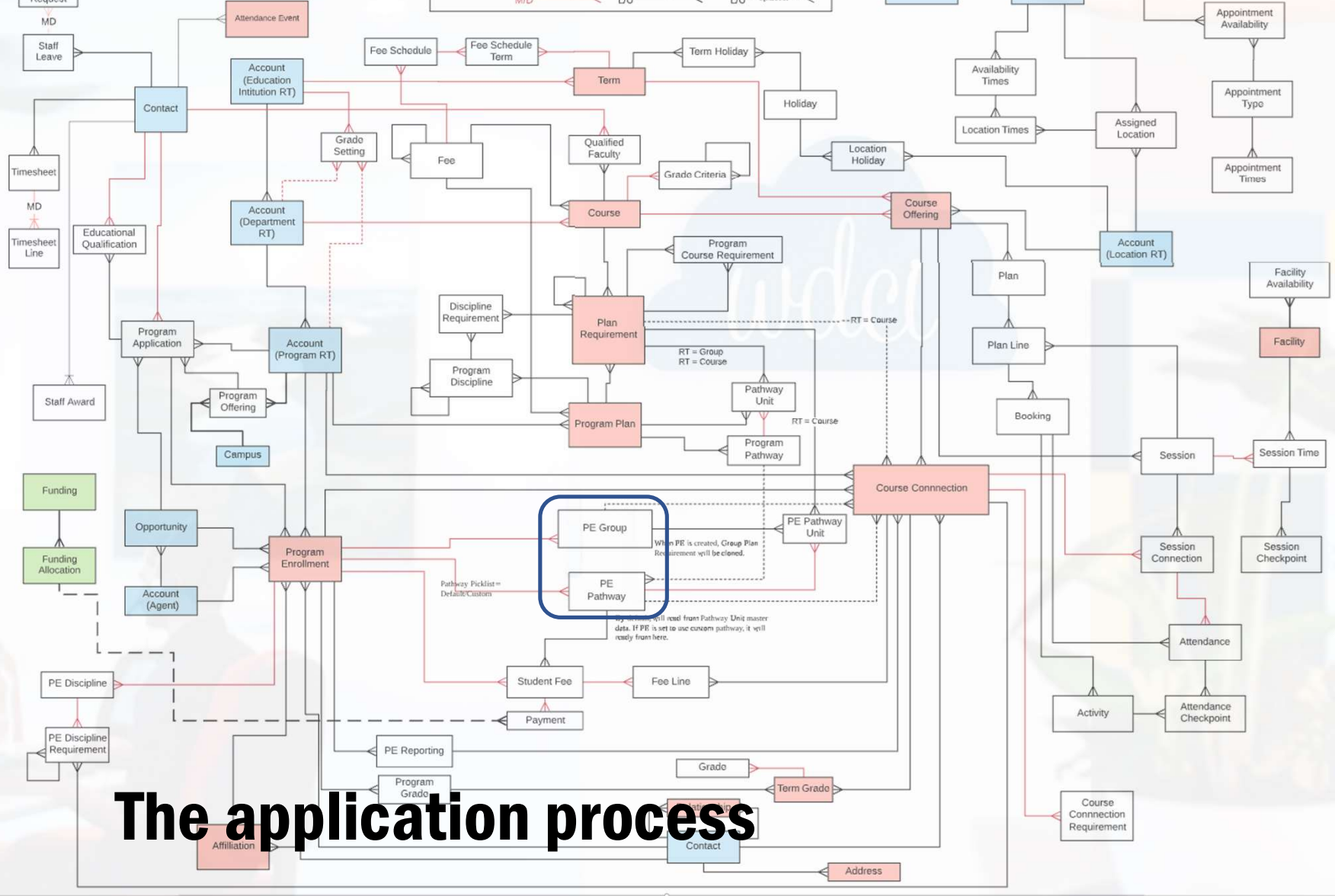
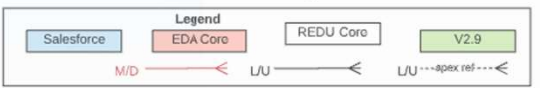

**PE Group and PE Pathway records are automatically created when an applicant accepts enrolling into a Program.**

**PE Group will be used to calculate student completion.**

**PE Pathway will be used to offer students Course for enrollment.**



Enrollment  
**PE-0025**

Contact: Sarah Smith    Program: Bachelor of Business Information System    Start Date: 5/03/2018    GPA: 4.140    Enrollment Standing: OK

Student enrollment in Courses for each Term is tracked down here

Details    **Pathways**    Unit Enrollments    Student Fees    PE Disciplines    Program Completion    Grades

**PE Pathways (6+)** New

PE Pathway ID	My Term	Term	Status
PEP-0120	1	Semester 1 2018	Completed
PEP-0121	2	Semester 2 2018	Completed
PEP-0122	3	Semester 1 2019	Completed
PEP-0123	4	Semester 2 2019	Completed
PEP-0124	5	Semester 1 2020	Completed
PEP-0125	6	Semester 2 2020	Completed
PEP-0402	7	Semester 1 2021	Completed
PEP-0403	8	Semester 2 2021	Current

[View All](#)

**PE Groups (2)** New

PE Group Name	Completion Progress	Group Status	Credits
RIOUNI02-Mandatory	<div style="width: 56%;"></div> 56%	In Progress	160.000
RIOUNI02-Electives	<div style="width: 100%;"></div> 100%	Completed	80.000

[View All](#)

# The application process



# wdci

Introduction to RIO Education:

## Enrollment







RIO Education Data Model v2.9

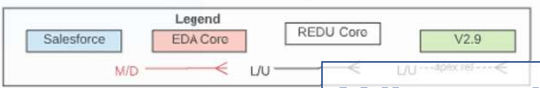

What other records are created along with a Program Enrollment?

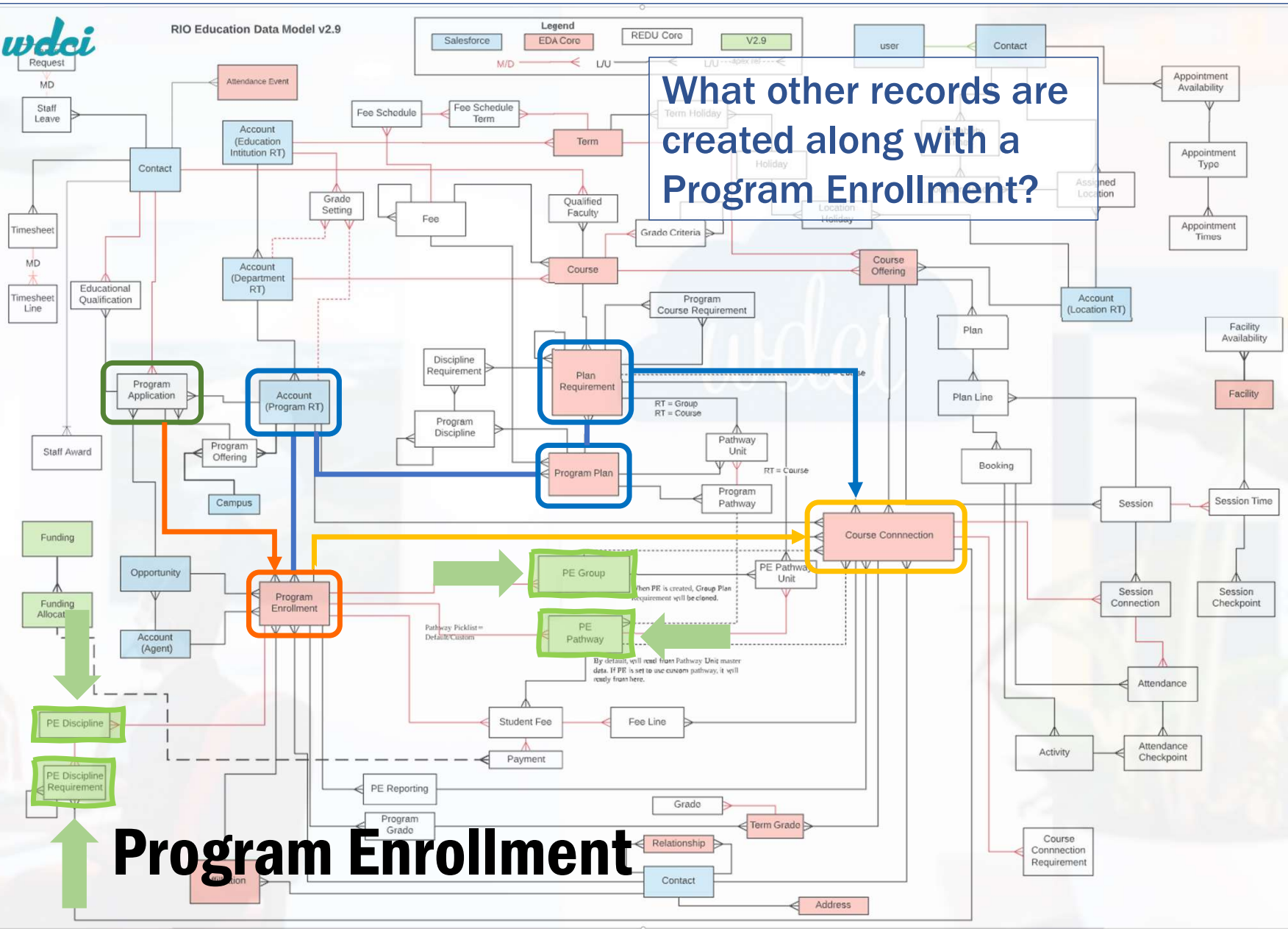

**Program Enrollment**

Whenever a Program Application is approved,

A **PROGRAM ENROLLMENT** record is created...

And when this happens, many **COURSE CONNECTIONS** are created...

but how many?

As many as **mandatory PLAN REQUIREMENTS** there are.



## There are three steps to create a Program Enrollment:

- 1. Open a new Program Enrollment data entry form for the student**
- 2. Select the Program in which the student enrolls**
- 3. Select the 'Enrollment Status' that will determine the student's Pathway**

(There are some other mandatory fields but forget about them for the time being)

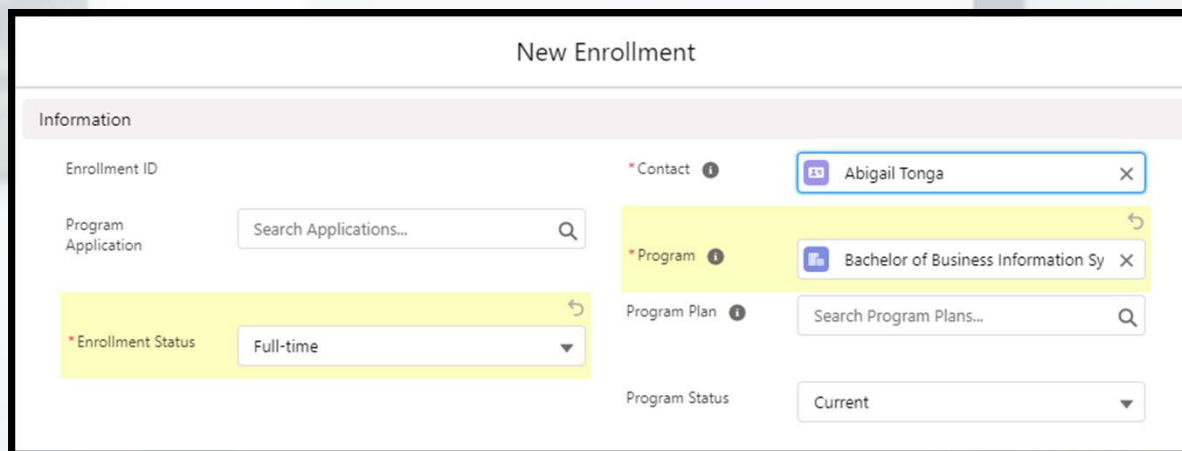

The screenshot shows a web form titled "New Enrollment". It contains several fields:

- Enrollment ID:** A text input field.
- Program Application:** A search field with the placeholder text "Search Applications..." and a magnifying glass icon.
- Enrollment Status:** A dropdown menu currently showing "Full-time".
- Contact:** A dropdown menu showing "Abigail Tonga".
- Program:** A dropdown menu showing "Bachelor of Business Information Sy".
- Program Plan:** A search field with the placeholder text "Search Program Plans..." and a magnifying glass icon.
- Program Status:** A dropdown menu currently showing "Current".

## Program Enrollment



## In creating a new Program Enrollment record:

### 1. **Course Connections are created** (although they are not linked to any Course Offering)

They are only linked to:

- A Plan Requirement
- A PE Group

# Program Enrollment



The system's automation has created as many Unit Enrollments (aka Course Connections) as mandatory Plan Requirements are

Program Enrollment

Enrollments > PE-0536  
**Unit Enrollments**  
28 items • Updated 19 minutes ago

	Uni... ▾	Plan Requirement (Unit)	Unit Offering ID	Term	Enrollment Status
1	CC-7849	RIOUNI022018 - BUS101			
2	CC-7850	RIOUNI022018 - BUS102			
3	CC-7851	RIOUNI022018 - BUS104			
4	CC-7852	RIOUNI022018 - BUS105			
5	CC-7853	RIOUNI022018 - BUS106			
6	CC-7854	RIOUNI022018 - BUS108			
7	CC-7855	RIOUNI022018 - BUS203			
8	CC-7856	RIOUNI022018 - BUS211			
9	CC-7857	RIOUNI022018 - ICT112			
10	CC-7858	RIOUNI022018 - ICT115			
11	CC-7859	RIOUNI022018 - ICT211			
12	CC-7860	RIOUNI022018 - ICT221			
13	CC-7861	RIOUNI022018 - ICT310			
14	CC-7862	RIOUNI022018 - ICT320			
15	CC-7863	RIOUNI022018 - ICT352			
16	CC-7864	RIOUNI022018 - MGT325			
17	CC-7876	Internship			



It is only when a **Unit Offering** is linked to the **Course Connection** that we can specify an **Enrollment Status** for the student

Enrollments > PE-0535  
Unit Enrollments

28 Items • Updated a few seconds ago

	Uni...	Plan Requirement (Unit)	Unit Offering ID ↑	Term	Enrollment Status	Grade	Grade Value	Grade R...	Credits ...	Require...
1	CC-7805	RIOUNI022018 - BUS101	Sydney Campus - BUS101 Semester 1 2020	Semester 1 2020	Completed	78.00	D - Distinction	Pass	10.000	<input checked="" type="checkbox"/>
2	CC-7806	RIOUNI022018 - BUS102	Sydney Campus - BUS102 Semester 1 2020	Semester 1 2020	Completed	89.00	HD - High Distinction	Pass	10.000	<input checked="" type="checkbox"/>
3	CC-7807	RIOUNI022018 - BUS104	Sydney Campus - BUS104 Semester 1 2021	Semester 1 2021	Enrolled					<input checked="" type="checkbox"/>
4	CC-7808	RIOUNI022018 - BUS105	Sydney Campus - BUS105 Semester 1 2021	Semester 1 2021	Enrolled					<input checked="" type="checkbox"/>
5	CC-7809	RIOUNI022018 - BUS106								<input checked="" type="checkbox"/>
6	CC-7810	RIOUNI022018 - BUS108								<input checked="" type="checkbox"/>
7	CC-7812	RIOUNI022018 - BUS211								<input checked="" type="checkbox"/>
8	CC-7813	RIOUNI022018 - ICT112	Sydney Campus - ICT112 Semester 1 2020	Semester 1 2020	Completed	74.00	CR - Credit	Pass		<input checked="" type="checkbox"/>
9	CC-7814	RIOUNI022018 - ICT115	Sydney Campus - ICT115 Semester 1 2020	Semester 1 2020	Completed	57.00	PS - Pass		10.000	<input checked="" type="checkbox"/>
10	CC-7815	RIOUNI022018 - ICT211								<input checked="" type="checkbox"/>
11	CC-7817	RIOUNI022018 - ICT310								<input checked="" type="checkbox"/>
12	CC-7818	RIOUNI022018 - ICT320								<input checked="" type="checkbox"/>
13	CC-7819	RIOUNI022018 - ICT352								<input checked="" type="checkbox"/>
14	CC-7820	RIOUNI022018 - MGT325								<input checked="" type="checkbox"/>
15	CC-7821	RIOUNI022018 - BUS301								<input checked="" type="checkbox"/>
16	CC-7822	RIOUNI022018 - BUS320								<input checked="" type="checkbox"/>
17	CC-7823	RIOUNI022018 - COR109								<input checked="" type="checkbox"/>
18	CC-7824	RIOUNI022018 - HRM311								<input checked="" type="checkbox"/>
19	CC-7825	RIOUNI022018 - HRM321								<input checked="" type="checkbox"/>
20	CC-7826	RIOUNI022018 - IBS220								<input checked="" type="checkbox"/>
21	CC-7827	RIOUNI022018 - ICT120								<input checked="" type="checkbox"/>
22	CC-7828	RIOUNI022018 - ICT341								<input checked="" type="checkbox"/>
23	CC-7829	RIOUNI022018 - MGT210								<input checked="" type="checkbox"/>
24	CC-7830	RIOUNI022018 - MGT310								<input checked="" type="checkbox"/>
25	CC-7831	RIOUNI022018 - MGT322								<input checked="" type="checkbox"/>
26	CC-7832	Internship								<input checked="" type="checkbox"/>
27	CC-7838	RIOUNI022018 - ICT221	Sydney Campus - ICT221 Semester 1 2021	Semester 1 2021	Enrolled					<input checked="" type="checkbox"/>
28	CC-7845	RIOUNI022018 - BUS203								<input checked="" type="checkbox"/>

Remember, the creation of a **Course Connection** does not imply that the student gets enrolled in a Course until:

- a Course Offering has been linked to it and
- its status has been set to 'Enrolled'

# Program Enrollment





28 items • Updated 19 minutes ago

	Uni...	Plan Requirement (Unit)
1	CC-7849	RIOUNI022018 - BUS101
2	CC-7850	RIOUNI022018 - BUS102
3	CC-7851	RIOUNI022018 - BUS104
4	CC-7852	RIOUNI022018 - BUS105
5	CC-7853	RIOUNI022018 - BUS106
6	CC-7854	RIOUNI022018 - BUS108
7	CC-7855	RIOUNI022018 - BUS203
8	CC-7856	RIOUNI022018 - BUS211
9	CC-7857	RIOUNI022018 - ICT112
10	CC-7858	RIOUNI022018 - ICT115
11	CC-7859	RIOUNI022018 - ICT211
12	CC-7860	RIOUNI022018 - ICT221
13	CC-7861	RIOUNI022018 - ICT310
14	CC-7862	RIOUNI022018 - ICT320
15	CC-7863	RIOUNI022018 - ICT352
16	CC-7864	RIOUNI022018 - MGT325
17	CC-7865	RIOUNI022018 - BUS301
18	CC-7866	RIOUNI022018 - BUS320
19	CC-7867	RIOUNI022018 - COR109
20	CC-7868	RIOUNI022018 - HRM311
21	CC-7869	RIOUNI022018 - HRM321
22	CC-7870	RIOUNI022018 - IBS220
23	CC-7871	RIOUNI022018 - ICT120
24	CC-7872	RIOUNI022018 - ICT341
25	CC-7873	RIOUNI022018 - MGT210
26	CC-7874	RIOUNI022018 - MGT310
27	CC-7875	RIOUNI022018 - MGT322
28	CC-7876	Internship



Unit Offering ID	Term	Enrollment Status
------------------	------	-------------------

Program Enrollment



Unit Enrollment  
CC-7849

Contact: **Abigail Tonga** | Unit Offering ID: | Program Enrollment ID: **PE-0536** | Grade: | Primary:

**Details** | Sessions | Fee Lines | Requirements | Term Grades | History

Contact	Abigail Tonga	Contact's Academic Program	Bachelor of Business Information System
Record Type	Student	Program Enrollment ID	PE-0536
Status	Current	Enrollment Status	
Term		Unit Offering ID	
Unit		Primary	<input type="checkbox"/>
Unit ID		Requirement Met	<input checked="" type="checkbox"/>
Requirement Logic	A or B	Allow Pre-Enrollment	<input type="checkbox"/>
Hours Attended	0.00	EFTSL	
Attempt Number	1		
Session Rules Matching Status			
Reporting Information			
Dual Qualification Reporting			
Credit Transfer Information			
Date Information			
Fee Information			
Fee Method	Program - Yes	Fee Amount	
Fee Type	Self Paid	Upfront Payment	
Fee Type Option		Funding Assistance	
Course Connection Result			
Grade Setting Type	Educational Institution	Credits Offered	10.000
Grade		Credits Attempted	
Grade Value		Credits Earned	
Release Grades	<input type="checkbox"/>	Grade Points	
Ignore for GPA calculation	<input type="checkbox"/>	Grade Result	
		Ignore Credits Earned	<input type="checkbox"/>
System Information			
Owner	Adam Administrator	Created By	Adam Administrator, 2/07/2021 11:38 AM
PE Group	RIOUNI02-Mandatory	Last Modified By	Adam Administrator, 2/07/2021 11:38 AM
PE Pathway			
Plan Requirement (Unit)	RIOUNI022018 - BUS101		



## In creating a new Program Enrollment record:

(Do you remember what happens?)

1. **Course Connections are created**  
(although they are not linked to any Course Offering)
2. **PE Pathways and PE Groups are created**  
(sure thing... but HOW?)

# Program Enrollment



Program Enrollments entail the automatic generation of related records, which depends on the selected 'Enrollment method' at Program Pathway level:

- **Manual**
- **Automatic by term/course**
- **Automatic all terms (future)**

Remember: This option can be set in the Program Pathway!

Program Pathway  
**PP-0008**

Number of Terms: 6      Study Mode: Full-time

**Details**      Pathway Units

Program Pathway ID	PP-0008
Number of Terms ⓘ	6
Notes ⓘ	Full time study for the Bachelor of Information System
Study Mode	Full-time
Term Label ⓘ	Default
Program Plan	Bachelor of Business Information System V1
Enrollment Method	--None--
System Information	✓ --None--
Owner	
Created By	

Manual  
Automatic by term/unit  
Automatic all terms



## Program Enrollment

Program Enrollments entail the automatic generation of related records, which depends on the selected 'Enrollment method' at Program Pathway level:

- Manual
- Automatic by term/course
- Automatic all terms (future)

# Program Enrollment

### No Term lookup

Enrollment PE-0536

Contact: Abigail Tonga | Program: Bachelor of Business Information System

Start Date | GPA | Enrollment Standing

Details | **Pathways** | Unit Enrollments | Student Fees | PE Disciplines | Program Completion | Grades

PE Pathways (6)

PE Pathway ID	My Term	Term	Status
PEP-0533	1		Future
PEP-0534	2		Future
PEP-0535	3		Future
PEP-0532	4		Future
PEP-0536	5		Future
PEP-0537	6		Future

### Automatically Enroll in Courses = false

PE Pathway PEP-0533

Number of Terms: 6 | My Term: 1 | Study Mode: Full-time | Status: Future | Term

Details | PE Pathway Units | Unit Enrollments | Student Fees

Notes: Full time study for the Bachelor of Business Management | Deferred:

Term Start Date

Result Information

GPA: -5.50 | All Courses Completed?:  | All Courses Passed?:  | Credits Attempted: | Credits Earned:

System Information

PE Pathway ID: PEP-0529 | My Term: 1 | Automatically Enroll in Courses:

Program Pathway: PP-0008 | Program Enrollment: PE-0535

Created By: Adam Administrator, 30/03/2021 4:20 PM | Last Modified By: Adam Administrator, 30/03/2021 4:20 PM

Term: | My Term: 1





Program Enrollments entail the automatic generation of related records, which depends on the selected 'Enrollment method' at Program Pathway level:

- Manual
- **Automatic by term/course**
- Automatic all terms (future)

**1<sup>st</sup> Term = Starting Term (from PE)**

Enrollment PE-0536

Contact: Abigail Tonga | Program: Bachelor of Business Information System

Start Date | GPA | Enrollment Standing

Details | **Pathways** | Unit Enrollments | Student Fees | PE Disciplines | Program Completion | Grades

PE Pathways (6)

PE Pathway ID	My Term	Term	Status
PEP-0533	1	Semester 2 2021	Future
PEP-0534	2		Future
PEP-0535	3		Future
PEP-0532	4		Future
PEP-0536	5		
PEP-0537	6		

**PE Pathway PEP- 0533**

Number of Terms: 6 | My Term: 1 | Study Mode: Full-time | Status: Future | Term

**Automatically Enroll in Courses = true**

Details | PE Pathway Units | Unit Enrollments | Student Fees

Notes: Full time study for the Bachelor of Business Management | Deferred:

Term Start Date

Result Information

GPA: -5.50 | All Courses Completed?:  | All Courses Passed?:  | Credits Attempted: | Credits Earned:

System Information

PE Pathway ID: PEP-0529 | 1 | **Automatically Enroll in Courses:**

Program Pathway: PP-0008 | Program Enrollment: PE-0535

Created By: Adam Administrator, 30/03/2021 4:20 PM | Last Modified By: Adam Administrator, 30/03/2021 4:20 PM

Term: | My Term: 1

# Program Enrollment



Program Enrollments entail the automatic generation of related records, which depends on the selected 'Enrollment method' at Program Pathway level:

- Manual
- Automatic by term/course
- Automatic all terms (future)

# Program Enrollment

**1<sup>st</sup> Term = Starting Term (from PE)**

**Following Terms = Cascade as per 'Previous Term'**

PE Pathway ID	My Term	Term	Status
PEP-0526	1	Semester 1 2020	Current
PEP-0527	2	Semester 2 2020	Future
PEP-0528	3	Semester 1 2021	Future
PEP-0529	4	Semester 2 2021	Future
PEP-0530	5	Semester 1 2022	Future
PEP-0531	6	Semester 2 2022	Future

Details	PE Pathway Units	Unit Enrollments	Student Fees	
Notes	Full time study for the Bachelor of Business Management		Deferred <input type="checkbox"/>	
Term Start Date				
Result Information				
GPA		All Courses Completed?	<input type="checkbox"/>	
GPA Trend	-5.50	All Courses Passed?	<input type="checkbox"/>	
Credits Attempted		Credits Earned		
System Information				
PE Pathway ID	PEP-0529	1	Automatically Enroll in Courses <input checked="" type="checkbox"/>	
Program Pathway	PP-0008		Program Enrollment	PE-0535
Created By	Adam Administrator, 30/03/2021 4:20 PM		Last Modified By	Adam Administrator, 30/03/2021 4:20 PM
Term			My Term	1

Program Enrollment (Manual)

Enrollment PE-0536

Contact: Abigail Tonga | Program: Bachelor of Business Information System | Start Date: | GPA: | Enrollment Standing:

Details | **Pathways** | Unit Enrollments | Student Fees | PE Disciplines | Program Completion | Grades

**PE Pathways (6)**

PE Pathway ID	My Term	Term	Status
PEP-0533	1		Completed
PEP-0534	2		Future
PEP-0535	3		Future
PEP-0532	4		Future
PEP-0536	5		Future
PEP-0537	6		Future

[View All](#)

**PE Groups (3)**

PE Group Name	Completion Progress	Group Status	Credits
RIOUNI02-Mandatory	<input type="text"/> 0%		160.000
RIOUNI02-Electives	<input type="text"/> 0%		80.000
Internship	<input type="text"/> 0%		40.000

[View All](#)



What implications does this have?

The implication is that PE Pathways AND their relationship with Course Connections will have to be created manually every Term the student enrolls in Courses

## In creating a new Program Enrollment record:

(Do you remember what happens?)

1. **Course Connections are created**  
(although they are not linked to any Course Offering)
2. **PE Pathways and PE Groups are created**

Finally, and unless the current Term's PE Pathway has already been populated:

3. **The Administrator must set up a Term for every PE Pathway record manually**

(this is the only way PE Pathways will get connected to a Course Connection when such Course Connection's is updated with

- a specific Course Offering
- the field 'Enrollment Status' = "Enrolled")

## Program Enrollment (Manual)



## Normally, enrollment into a Program happens through the Student Community:

The screenshot shows the RIO Pathway web interface. At the top, there is a navigation bar with the RIO logo and a graduation cap icon, followed by menu items: HOME, MY DETAILS, MY ACHIEVEMENTS, NEW APPLICATION, CO-CURRICULAR, and More with a dropdown arrow. On the right side of the navigation bar are a notification bell icon and a user profile icon. Below the navigation bar, the page title is "PATHWAY". A paragraph of text explains the pathway module's functions: "Pathway is your one-stop module to allow you to perform the following actions; to enroll into units, sessions, to pay your fees online, check your progress - results based on semesters, select and view your majors/minors. Please contact the support team if you have any difficulties in using the pathway module. You can raise a support ticket in this portal or head on to our student support office." Below this text is a horizontal line. Underneath the line, there is a left-pointing arrow icon. The main content area features three cards. The first card is titled "Semester 1 2021" and has a "View Results" button. The second card is titled "Semester 2 2021" and has a "Select" button, which is highlighted with a red arrow. The third card is titled "No Term selected" and has a "Select Term" button.

## Course Enrollment





With each Program Enrollment, all the necessary

- Course Connection
- PE Pathways

are provisioned for students to enroll into Courses on the Student Community:

PATHWAY

Pathway is your one-stop module to allow you to perform the following actions; to enroll into units, sessions, to pay your fees online, check your progress - results based on semesters, select and view your majors/minors. Please contact the support team if you have any difficulties in using the pathway module. You can raise a support ticket in this portal or head on to our student support office.

Units Sessions Payment

View my Units View All Campuses

UNIT ID UNIT NAME CAMPUS STATUS ACTION

RIOUNI02-Electives (Pick 2 Units from below)

UNIT ID	UNIT NAME	CAMPUS	STATUS	ACTION
BUS301	BUS301 Business Analytics 2	Campus: Sydney	Enrolled for Semester 2 2021	X
BUS320	BUS320 Corporate Governance and Social Responsibility	Campus: Sydney	40 place(s) available	✓ Enroll
COR109	COR109 Communication and Thought	Campus: Sydney	40 place(s) available	✓ Enroll
HRM311	HRM311 Leadership and Team Dynamics	Campus: Sydney	Enrolled for Semester 2 2021	X
HRM321	HRM321 Managing Organisational Change	Campus: Sydney	40 place(s) available	✓ Enroll
IBS220	IBS220 Cross-Cultural Management	Campus: Sydney	40 place(s) available	✓ Enroll
ICT120	ICT120 Introduction to Telecommunications and Networks	Campus: Sydney	40 place(s) available	✓ Enroll
ICT341	ICT341 ICT Internship	Campus: Sydney	Enrollment Requirements not met	
MGT210	MGT210 Project Management	Campus: Sydney	40 place(s) available	✓ Enroll
MGT310	MGT310 Small Business and New Venture Management	Campus: Sydney	Enrollment Requirements not met	
MGT322	MGT322 Advanced Strategic Management	Campus: Sydney	Enrollment Requirements not met	
RIOUNI02-Mandatory				
BUS108	BUS108 Introduction to Informatics	Campus: Sydney	Enrolled for Semester 2 2021	X
ICT310	ICT310 Systems Analysis and Design	Campus: Sydney	40 place(s) available	✓ Enroll

Each time a student enrolls a Course,

a) The provisioned Course Connection gets populated with the appropriate Course Offering;

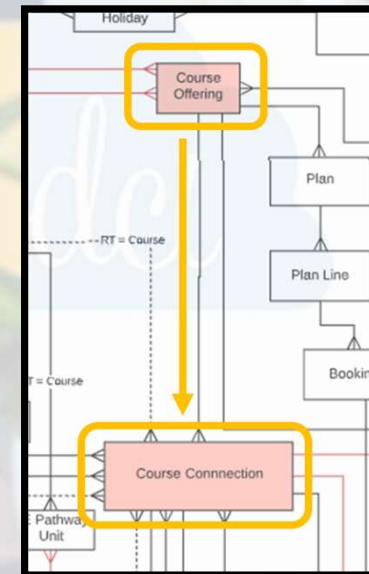

With each Program Enrollment, all the necessary

- Course Connection
- PE Pathways

are provisioned for students to enroll into Courses on the Student Community:

Each time a student enrolls a Course,

- a) The provisioned Course Connection gets populated with the appropriate Course Offering;
- b) The provisioned PE Pathway gets populated with the appropriate Term and therefore linked to the Course Connection.

UNIT ID	UNIT NAME	CAMPUS	STATUS	ACTION
<b>RIOUNI02-Electives (Pick 2 Units from below)</b>				
BUS301	BUS301 Business Analytics 2	Campus: Sydney	Enrolled for Semester 2 2021	X
BUS320	BUS320 Corporate Governance and Social Responsibility	Campus: Sydney	40 place(s) available	✓ Enroll
COR109	COR109 Communication and Thought	Campus: Sydney	40 place(s) available	✓ Enroll
HRM311	HRM311 Leadership and Team Dynamics	Campus: Sydney	Enrolled for Semester 2 2021	X
HRM321	HRM321 Managing Organisational Change	Campus: Sydney	40 place(s) available	✓ Enroll
IBS220	IBS220 Cross-Cultural Management	Campus: Sydney	40 place(s) available	✓ Enroll
ICT120	ICT120 Introduction to Telecommunications and Networks	Campus: Sydney	40 place(s) available	✓ Enroll
ICT341	ICT341 ICT Internship	Campus: Sydney	Enrollment Requirements not met	
MGT210	MGT210 Project Management	Campus: Sydney	40 place(s) available	✓ Enroll
MGT310	MGT310 Small Business and New Venture Management	Campus: Sydney	Enrollment Requirements not met	
MGT322	MGT322 Advanced Strategic Management	Campus: Sydney	Enrollment Requirements not met	
<b>RIOUNI02-Mandatory</b>				
BUS108	BUS108 Introduction to Informatics	Campus: Sydney	Enrolled for Semester 2 2021	X
ICT310	ICT310 Systems Analysis and Design	Campus: Sydney	40 place(s) available	✓ Enroll

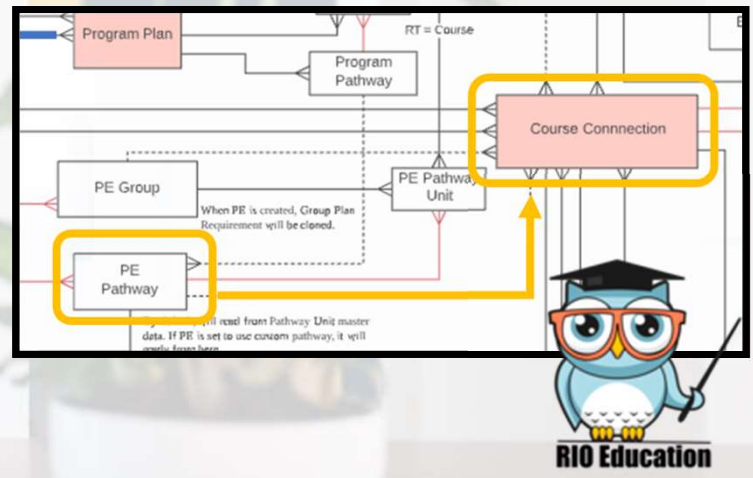

**But all this happens this way if course enrollment happens on the Student Community.**

**Otherwise, an administrator must enroll students into Courses by updating CCs and PE Pathways manually**

**Course Enrollment**



**REMEMBER!**

## **An important comment when creating COURSE CONNECTIONS manually:**

**Make sure a Course Connection always has:**

- A related Program Enrollment**
- A related Course Offering**
- A related Plan Requirement (Course)**
- A related PE Pathway**
- A related PE Group**

There is a class called CSEN\_PopulateFromCO\_TDTM, which can repopulate some of the Course Connection's fields, in case they are blank. If a Course Connection has both a Program Enrollment and a Course Offering, that means it's able to find any of the three remaining ones. However, creating a CC manually usually does not guarantee that this trigger runs so make sure these relationships are always in place!

## **Course Enrollment**



# wdci

Introduction to RIO Education:  
**Session setup**

The Cloud Solutions Company

wdci





wdci

First of all...

**How do we get to a Session Time record from an Educational Institution record?**

**Session setup**



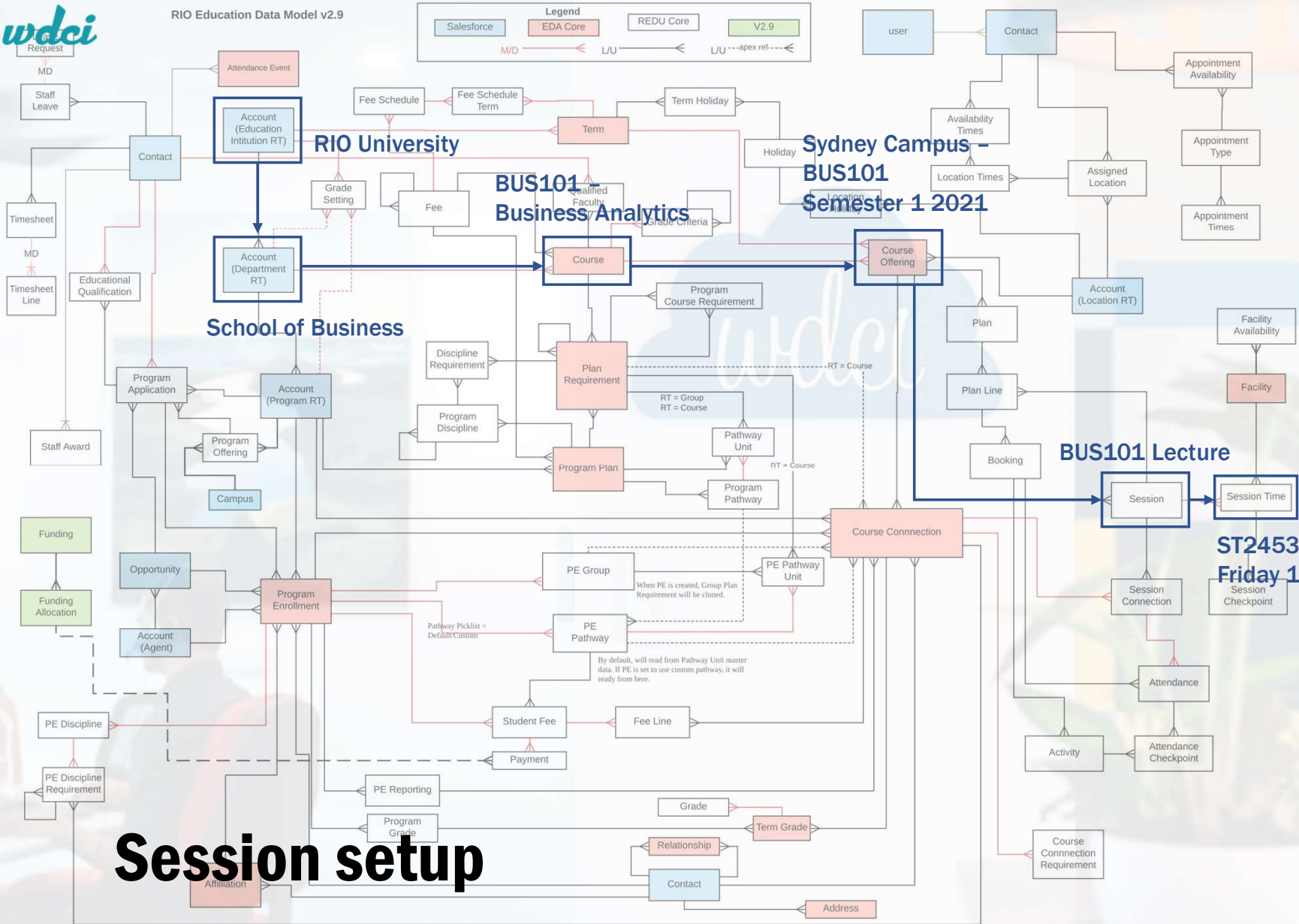

**A Course Offering can have multiple Sessions and each Session can have multiple Session Times**

**Sydney Campus - BUS101 Semester 1 2021**

**BUS101 Lecture**

**ST2453: Friday 1pm-3pm**

**Session setup**



# Session setup

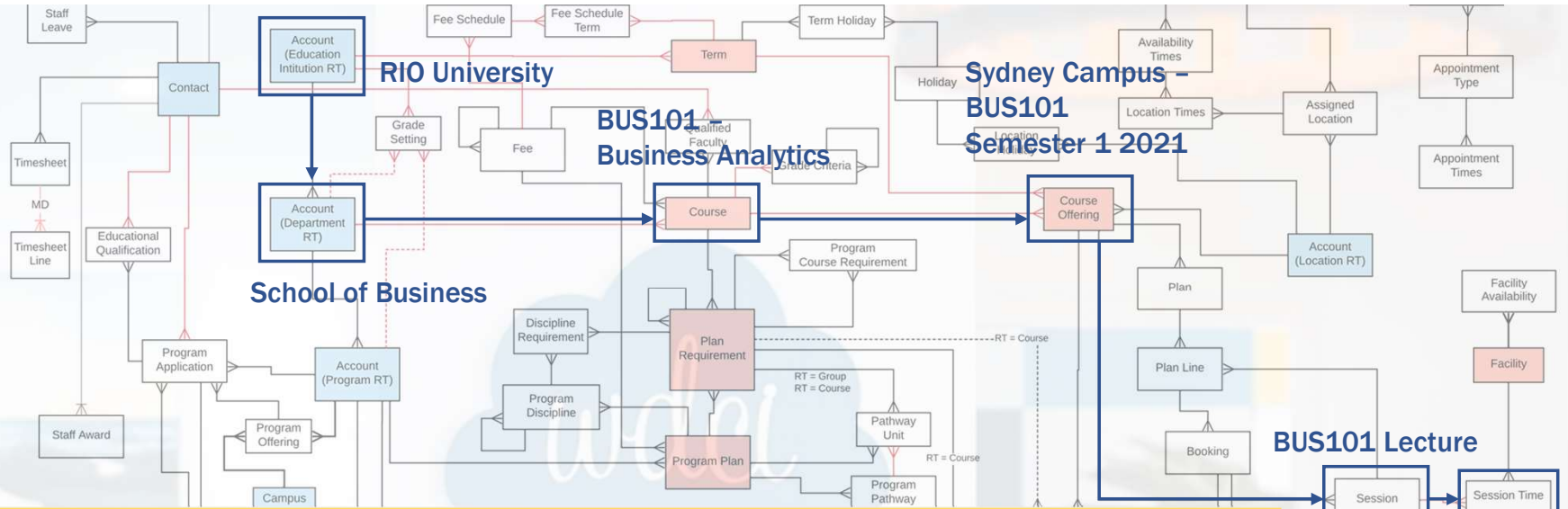

Sydney Campus -  
BUS101  
Semester 1 2021

BUS101  
Business Analytics

School of Business

BUS101 Lecture

ST2453:  
Friday 1pm-3pm

Account  
**RIO University**

Account Record Type: Educational Institution | Parent Account: | Website: www.riouniversity.edu.au

Details	Grade Settings	Terms	Addresses	Time Blocks
Account Name: RIO University			Billing Address: 15 Bingera Terrace, Caloundra QLD 4551, Australia	
Account Record Type: Educational Institution			Shipping Address:	
Phone: +61 288 889 999				
Fax:				
Current Address: A-00074				
Description: EFTSL (Credit Points): 80				
System Information: Created By: Violet Newstead, 5/11/2018 6:07 PM				
Account Owner: Amy Adams				

Activity | Chatter

Log a Call | New Task | New Event

Recap your call... [Add]

Filters: All time • All activities • All types

Refresh • Expand All • View All

Upcoming & Overdue

No next steps.  
To get things moving, add a task or set up a meeting.

No past activity. Past meetings and tasks marked as done show up here.



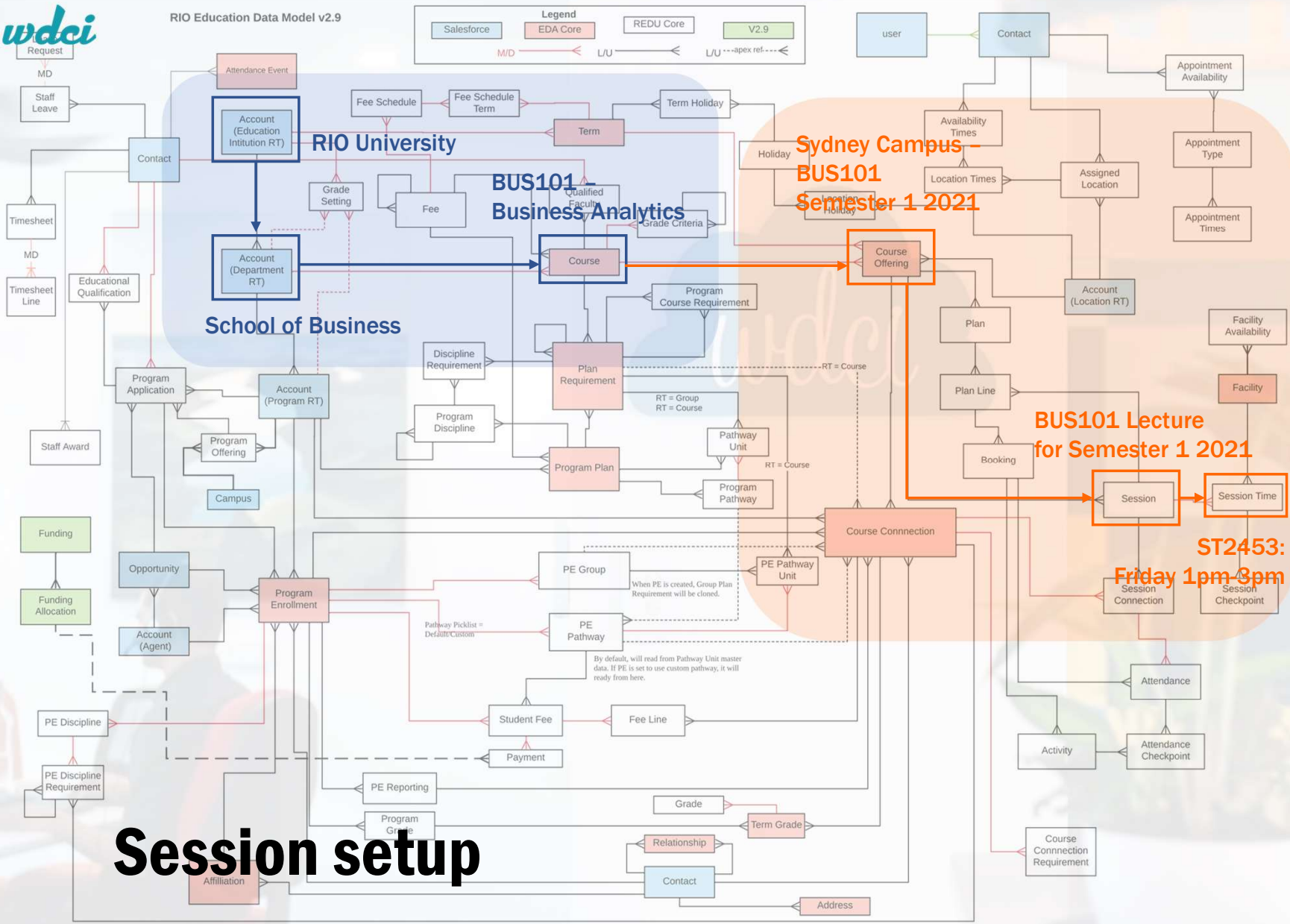

This side of the data structure is **STATIC**

It does not change over the academic terms

This side of the data structure is **DYNAMIC**

**Session setup**



# So, prior to creating a Session,

We must have a Unit Offering to link our Sessions to

**Unit Offering**  
**Sydney Campus - BUS101 Semester 1 2021**

Unit	Start Date	Primary Faculty	Capacity
BUS101: Business Analytics	4/01/2021	Fran Fisher	40

# When adding Sessions,

we must make sure that they all have a start date and an end date

Details **Sessions** Students Faculty

**Sessions (3)**

Session Name	Session Type
BUS101 Lecture	Recurring
BUS101 Tutorial 01	Recurring
BUS101 Tutorial 02	Recurring

**Session**  
**BUS101 Lecture**

Number of Sessions	Capacity	Booked Places	Available Places
15	80	2	78

**Details** Students Faculty Attendance

Session Name	BUS101 Lecture	Record Type	Class
Session Type	Lecture	Owner	Adam Administrator
Unit Offering	Sydney Campus - BUS101 Semester 1 2021	Published	<input checked="" type="checkbox"/>
Capacity	80	Self Enrollment Disabled	<input type="checkbox"/>
Number of Sessions	15		
Required Facility Type	Classroom		
Band			
Description			
<b>Session Date/Time</b>			
Pre-enrollment Open Date		Booking Status	Booked with Issue
Enrollment Open Date		Session Status	Completed
Enrollment Close Date		Session Status (Override)	
Session Start Date	1/03/2021		
Session End Date	29/06/2021		
Break Time			

# Session setup in action





Then,

We must create Session Times

(we will come back to Session Times later)

Session **BUS101 Lecture**

+ Follow Edit Clone Delete

Number of Sessions	Capacity	Booked Places	Available Places
15	80	2	78

Details Students Faculty Attendance

Session Name	BUS101 Lecture	Record Type	Class
Session Type	Lecture	Owner	Adam Administrator
Unit Offering	Sydney Campus - BUS101 Semester 1 2021	Published	<input checked="" type="checkbox"/>
Capacity	80	Self Enrollment Disabled	<input type="checkbox"/>
Number of Sessions	15		
Required Facility Type	Classroom		
Band			
Description			

Related Chatter Activity

<b>Session Times (2)</b>	
<a href="#">ST-2453</a>	Friday, 13:00-15:00
Label:	Friday
Recurrence:	Weekly
Day of week:	Friday
<a href="#">ST-3123</a>	Thursday, 11:00-14:00
Label:	Thursday
Recurrence:	Weekly
Day of week:	Thursday

[View All](#)



**Session setup in action**

# We can create different types of Sessions for the same Course

**Unit Offering**  
**Sydney Campus - BUS101 Semester 1 2021**

Unit	Start Date	Primary Faculty	Capacity
BUS101: Business Analytics	4/01/2021	Fran Fisher	40

**Unit Offering**  
**Sydney Campus - BUS101 Semester 1 2021**

Unit	Start Date	Primary Faculty	Capacity
BUS101: Business Analytics	4/01/2021	Fran Fisher	40

**Details** Sessions Students Faculty

Unit: BUS101: Business Analytics

Unit Offering ID: Sydney Campus - BUS101 Semester 1 2021

Unit Delivery Method: [edit]

Scheduled Duration: [edit]

Scheduled Duration Unit: [edit]

Default: [checkbox]

**Session Rules**: Lecture=1;Tutorial=1

Maybe not both tutorials are mandatory. You might need to choose one of these two options

Details **Sessions** Students Faculty

**Sessions (3)** [New]

Session Name	Session Type	Number of Sessions	Capacity
BUS101 Lecture	Lecture	15	80
BUS101 Tutorial 01	Recurring	7	40
BUS101 Tutorial 02	Recurring	8	2

View All

## Session setup



We can choose whether to assign a **Primary Faculty** to this Session or to use the default one for the Unit Offering

If we choose the former, two things will happen.

**Details** Students Faculty Attendance

Session Name	BUS101 Lecture	Record Type	Class
Session Type	Lecture	Owner	Adam Administrator
Unit Offering	Sydney Campus - BUS101 Semester 1 2021	Published	<input checked="" type="checkbox"/>
Capacity	80	Self Enrollment Disabled	<input type="checkbox"/>
Number of Sessions	15		
Required Faculty Type	Classroom		
Band			
Description			
<b>Session Date/Time</b>			
Pre-enrollment Open Date		Booking Status	Booked with Issue
Enrollment Open Date		Session Status	Completed
Enrollment Close Date		Session Status (Override)	
Session Start Date	1/03/2021		
Session End Date	29/06/2021		
Break Time			
<b>Faculty Information</b>			
Use Unit Offering's Primary Faculty	<input type="checkbox"/>	Faculty Status	Some Confirmed
Primary Faculty	Fran Fisher		
<b>Additional Information</b>			
Use Checkpoints	<input type="checkbox"/>	Plan Line	BUS101 Lecture
Mandatory Attendance	<input type="checkbox"/>	Available Places	78
Attendance % for completion		Enable Waitlist	<input type="checkbox"/>
Booked Places	2	Waitlisted Places	0
<b>Grading Configuration</b>			
Grade Session Separately	<input type="checkbox"/>		
<b>Booking Issue Details</b>			
Booking Issue	There are Faculty double booking(s): 7		
Removed Booking Details	[Custom Booking Removed]: Friday 25 June 2021, 13:00-15:00 (Australia/Sydney), Faculty Member: Felix Ferguson, Frank Fisher [Custom Booking Removed]: Thursday 20 May 2021, 11:00-12:00 (Australia/Sydney), Resource: Room SYD-01		
<b>System Information</b>			
Created By	Adam Administrator, 12/01/2021 1:02 PM	Last Modified By	Adam Administrator, 5/07/2021 3:45 PM
Revalidate Faculty Allocation	<input type="checkbox"/>		

# Session setup



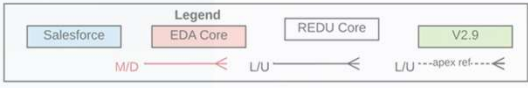

**Session**  
BUS101 Lecture

Number of Sessions: 15 | Capacity: 80 | Booked Places: 2 | Available Places: 78

Details | Students | **Faculty** | Attendance

Faculty Member	Faculty Roles	Start Date	End Date	Session Time
Fran Fisher		12/03/2021	29/06/2021	--None--
Felix Ferguson	Assistant	01/03/2021	29/06/2021	--None--

**Create Faculty Connections**

Filter by Faculty Roles:  Inactive

Qualified Faculty	Qualified Roles	Select
Fiona Forton	Lecturer:Tutor	Select
Fay Fox	Lecturer:Tutor	Select
Freddie Freeman	Lecturer:Lab Assistant:Tutor	Select
Fran Fisher	Lecturer:Tutor	Select
Felix Ferguson	Lecturer:Tutor:Assistant	Select

Faculty Member: Fran Fisher

Session Time: --None--

Faculty Confirmed

**Unconfirmed**

Start Date: [ ]

End Date: [ ]

Save Close

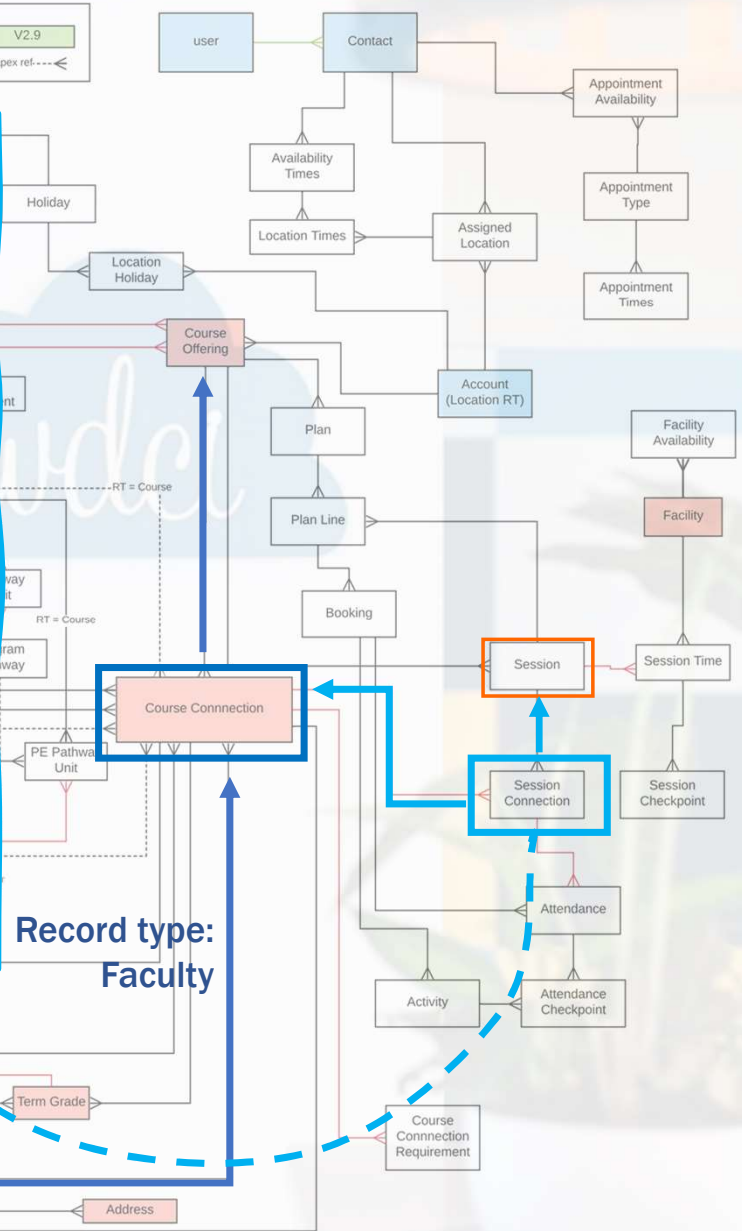

Record type: Faculty

**A Course Connection is created for the Faculty contact**

**A Session Connection is created for the Faculty member and flagged as "Unconfirmed"**

**(so the faculty can either accept or reject the session through the Faculty Community)**

# Session setup



This is the **Faculty Connection Wizard** and it allows an administrator to allocate multiple faculties for a Session as well as filtering available faculties by their qualified faculty roles

**Session setup**

Session **BUS101 Lecture**

Number of Sessions: 15    Capacity: 80    Booked Places: 2    Available Places: 78

Details    Students    **Faculty**    Attendance

Faculty Member	Faculty Roles	Start Date	End Date	Session Time
Fran Fisher		12/03/2021	29/06/2021	--None--
Felix Ferguson	Assistant	01/03/2021	29/06/2021	--None--

### Create Faculty Connections

Filter by Faculty Roles  Inactive

Qualified Faculty	Qualified Roles	Select
Fiona Forton	Lecturer;Tutor	Select
Fay Fox	Lecturer;Tutor	Select
Freddie Freeman	Lecturer;Lab Assistant;Tutor	Select
Fran Fisher	Lecturer;Tutor	Select
Felix Ferguson	Lecturer;Tutor;Assistant	Select

Faculty Member:

Session Time:

Faculty Confirmed:

Start Date:

End Date:

Lecturer  
 Lab Assistant  
 Tutor  
 Assistant

**Primary Faculty:**  
 Make Primary for Session  
 Make Primary for Unit Offering







RIO Education Data Model v2.9

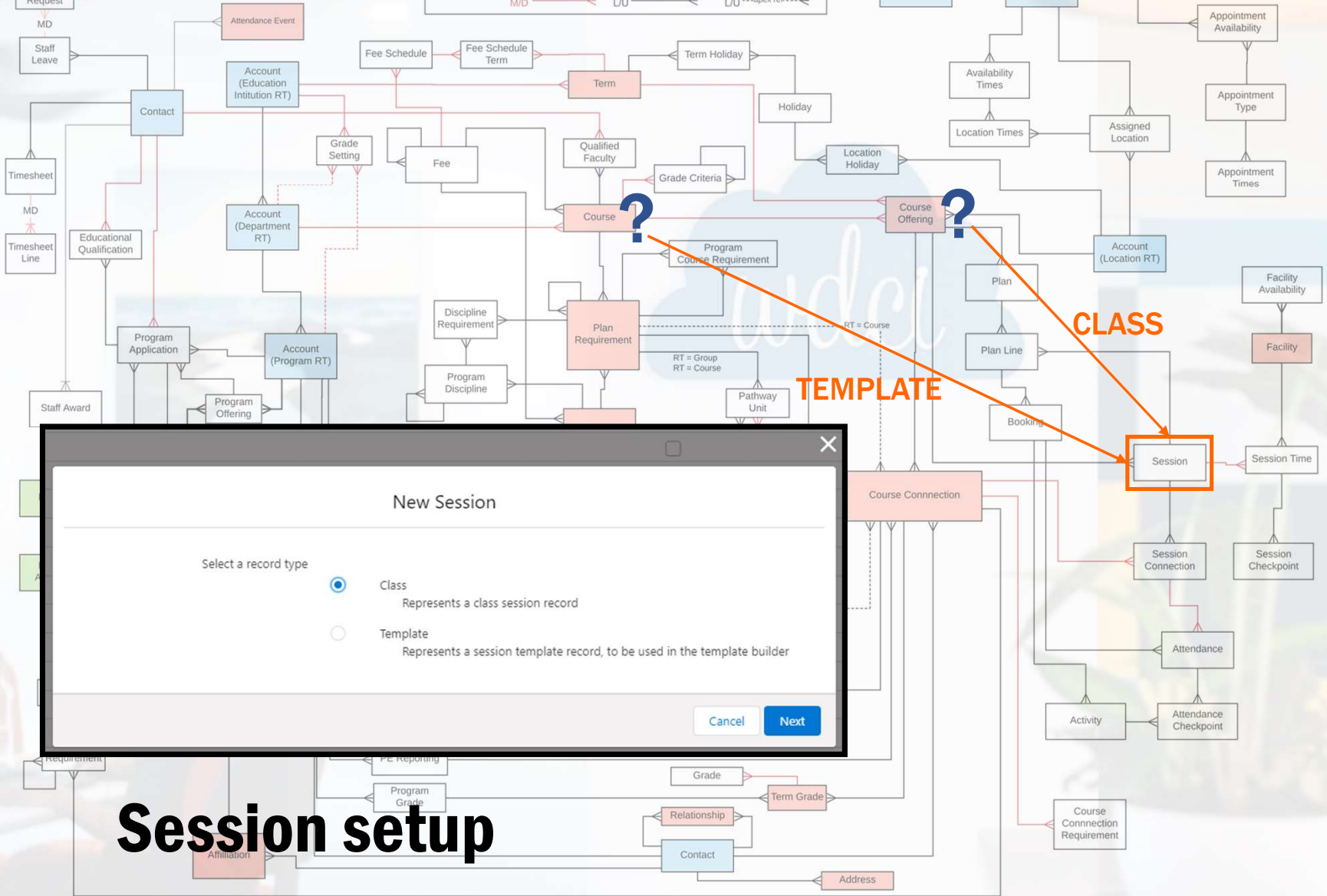
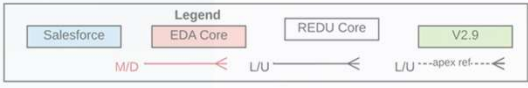

**New Session**

---

Select a record type

Class  
Represents a class session record

Template  
Represents a session template record, to be used in the template builder

# Session setup

## What object are Sessions dependent on?

Well... it depends on the Record Type!

## There are TWO Session record types:

- Class
- Template





### New Session: Class

#### Information

\* Session Name

Record Type  
Class

\* Session Type  
--None--

Owner  
June Review

\* Course Offering  
Search Course Offerings...

Published

Self Enrollment Disabled

\* Capacity

Number of Sessions

Required Facility Type  
--None--

Band  
--None--

Description

#### Session Date/Time

Pre-enrollment Open Date

Date

Time

Booking Status

Draft

Enrollment Open Date

Date

Time

Enrollment Status (Override)

Cancel Save & New Save

# Session setup

### New Session: Template

#### Information

\* Session Name

Record Type  
Template

\* Course  
Search Courses...

Owner  
June Review

\* Session Type  
--None--

Inactive

\* Capacity

Number of Sessions

Band  
--None--

Number of Booked Sessions

Description

Required Facility Type  
--None--

It may be a good idea to set up these first

#### Session Time

Break Time

Search Break Times...

#### Additional Information

Use Checkpoints

Mandatory Attendance

Attendance Marking

Each Session Time

Attendance % for completion

Cancel Save & New Save



When we create a Session, whether there is a *Class* or a *Template* record type, **We must create Session Times**

Session **BUS101 Tutorial Series #1**

Details Session Times

Session Times (2)

Session Time	Label
<a href="#">ST-0019</a>	M-09am-1h
<a href="#">ST-0020</a>	T-9am-1h

Session Time **ST-0019**

Day of week	Start Date	End Date	Start Time	End Time
Monday			09:00	10:00

Session Time: ST-0019

Session: [BUS101 Tutorial Series #1](#)

Facility:

Day of week: Monday

Recurrence: Weekly

Label: M-09am-1h

Ignore Holidays:

▼ Create/Update Settings

Create/Update Settings: Create/Update after today

Booking Change Date:

Status: Active

Start Time: 09:00

End Time: 10:00

Timezone:

Start Date:

End Date:

Please ensure at least 1 Session Time is defined and Session is booked

# Session setup



# Template record types are to be used in the Session Template Builder

## Template Builder

Template List

A

B

The screenshot shows the RIO Admin Console interface. At the top, there are navigation links for 'Home' and 'Acco'. A search bar contains the text 'session'. Below the search bar, there are sections for 'Apps', 'Items', and 'Sessions'. Under 'Items', the 'Session Template Builder' option is highlighted with an orange box. Other options include 'Session Scheduler' and 'View All'.

	Monday	Tuesday	Wednesday	Thursday	Friday
7am					
8am					
9am	9:00 - 10:00 BUS101 Tutorial Series #1	9:00 - 10:00 BUS101 Tutorial Series #1		9:00 - 10:00 BUS105 Tutorial Series #2	
10am					10:00 - 11:00 MGT210 Lecture Series #3
11am	11:00 - 12:00 ICT112 Tutorial Series #1	11:00 - 12:00 ICT112 Tutorial Series #1	11:00 - 12:00 ICT112 Tutorial Series #1	11:00 - 12:00 ICT115 Lecture Series #1	11:00 - 12:00 ICT115 Lecture Series #1
12pm			12:00 - 1:00 MGT210 Lecture Series #2		
1pm					
2pm	2:00 - 3:00 BUS104 Tutorial Series #1	2:00 - 3:00 MGT210 Lecture Series #1	2:00 - 3:00 BUS104 Tutorial Series #1	2:00 - 3:00 BUS105 Tutorial Series #1	2:00 - 3:00 BUS104 Tutorial Series #2
3pm		3:00 - 4:00 ICT115 Lecture Series #2	3:00 - 4:00 ICT112 Tutorial Series #1	3:00 - 4:00 ICT115 Lecture Series #2	3:00 - 4:00 ICT112 Tutorial Series #2
4pm	4:00 - 5:00 BUS105 Tutorial Series #1			4:00 - 5:00 BUS101 Tutorial Series #2	4:00 - 5:00 BUS101 Tutorial Series #2
5pm					
6pm					

# Session setup



# In turn, Templates can be used to schedule Sessions in the Session Scheduler

RIO Education Home Academic P...

session

**Apps**  
No results

**Items**

Session Planner

**Session Scheduler**

Session Template Builder

**Sessions**  
View All

Facility Faculty Member

**Session Scheduler**

Sessions

today

All

- BUS101 Lecture
- BUS101 Tutorial 01
- BUS101 Tutorial 02
- BUS102 Lecture
- BUS102 Tutorial
- BUS104 Lecture
- BUS104 Lecture
- BUS104 Tutorial Optio...
- BUS104 Tutorial Optio...
- BUS104 Tutorial Optio...
- BUS104 Tutorial Optio...
- BUS105 Lecture
- BUS105 Lecture

WK 2127

Facility	Mon 5						Tue 6						Wed 7		
	7am	8am	9am	10am	11am	12pm	1pm	2pm	3pm	4pm	5pm	6pm	7am	8am	9am
Workpad															
Preview															
Campus: Sydney															
Laboratory SYD-04			BUS104 Tutorial				BUS104 Tutorial					BUS104 Tutorial			
Laboratory SYD-05				BUS105						BUS105					
Laboratory SYD-06								ICT221 Tutorial 0							ICT221 Tutorial 0
Room SYD-01							BUS301					BUS108 Lecture			BUS301 Tutorial
Room SYD-02												BUS104	BUS105		
Room SYD-03				BUS104	ICT221 Lecture										

## Session setup





# Templates can be used to schedule Sessions in the Session Scheduler

## Template Builder

- Template List
- Accredited
  - BUS101 Lecture Template [edit]
  - BUS105 Lecture Template [edit]
  - BUS105 Tutorial Template [edit]
  - CPPREP5001 Lecture Template [edit]
  - CPPREP5001 Tutorial Template [edit]

	Monday	Tuesday	Wednesday	Thursday	Friday	Saturday	Sunday
7am							
8am							
9am	9:00 - 12:00 BUS105 Lecture Template				9:00 - 10:00 BUS105 Lecture Template		
10am							
11am			11:00 - 12:00 BUS105 Lecture Template				
12pm							
1pm					1:00 - 2:00 BUS105 Lecture Template		
2pm							
3pm							
4pm							
5pm							
6pm							

# Session setup in action



# Templates can be used to schedule Sessions in the Session Scheduler

The screenshot displays the 'Session Scheduler' interface. On the left, a sidebar lists various sessions, with 'BUS105 Lecture' selected. A red arrow points to a '+' button in the sidebar. The main area shows a 'New Session' modal with the following fields: 'Educational Institution' (RIO University), 'Unit' (BUS105 Introduction to Marketin...), 'Unit Offering' (Sydney Campus - BUS105 Semester 2 2021), and 'Band' (Please select one...). Below these fields, there are two 'Available Templates': 'BUS105 Lecture Template (Band: Accredited)' and 'BUS105 Tutorial Template (Band: Accredited)'. A red arrow points to a '+' button next to the 'BUS105 Lecture Template'. To the right of the modal, there is an 'Apply' button, also highlighted with a red arrow. At the bottom of the modal, there are 'Cancel', 'Save and Update Schedules', and 'Save' buttons. The background shows a calendar grid for 'Room SYD-03'.

**Session setup in action**



# Templates can be used to schedule Sessions in the Session Scheduler

## Template Builder

Template List

Accredited

BUS101 Lecture Template

BUS105 Lecture Template

BUS105 Tutorial Template

CPPREP5001 Lecture Template

CPPREP5001 Tutorial Template

	Monday	Tuesday	Wednesday	Thursday	Friday	Saturday	Sunday
7am							
8am							
9am	9:00 - 12:00 BUS105 Lecture Template				9:00 - 10:00 BUS105 Lecture Template		
10am							
11am			11:00 - 12:00 BUS105 Lecture Template				
12pm							
1pm					1:00 - 2:00 BUS105 Lecture Template		

## Edit Session

*Session Time: Label	*Day of week	*Recurrence	*Start Date	*Time	*End Date	*Time	Facility	*Status	Action
test1	Monday	Weekly	30/06/2021	9:00 AM	28/12/2021	12:00 PM	Please selec	Active	
Workshop	Wednesday	Weekly	30/06/2021	11:00 AM	28/12/2021	12:00 PM	Please selec	Active	
Lecture 2	Friday	Weekly	30/06/2021	1:00 PM	28/12/2021	2:00 PM	Please selec	Active	
Lecture 2	Friday	Weekly	30/06/2021	9:00 AM	28/12/2021	10:00 AM	Please selec	Active	

Cancel Save and Update Schedules Save



wdci **One additional note: you can select the proper kind of facility**

**Template Builder**

Template List

- Accredited
  - BUS101 Lecture Template
  - BUS105 Lecture Template**
  - BUS105 Tutorial Template
  - CPPREP5001 Lecture Template

	Monday	Sunday
7am		
8am		
9am	9:00 - 12:00 BUS105 Lecture Template	
10am		
11am		
12pm		

**Edit template**

Session Name: BUS105 Lecture Template

Band: Accredited

**Required Facility Type: Classroom**

Buttons: Cancel, Done

**Edit Session**

Required Facility Type: **Classroom**

*Session Time: Label	*Day of week	*Recurrence	*Start Date	*Time	*End Date	*Time	Action
test1	Monday	Weekly	30/06/2021	9:00 AM	28/12/2021	12:00 PM	
Workshop	Wednesday	Weekly	30/06/2021	11:00 AM	28/12/2021	12:00 PM	
Lecture 2	Friday	Weekly	30/06/2021	1:00 PM	28/12/2021	2:00 PM	
Lecture 2	Friday	Weekly	30/06/2021	9:00 AM	28/12/2021	10:00 AM	

Facility Selection List:

- None--
- \* Room SYD-01 (Max: N...
- \* Room SYD-02 (Max: N...
- \* Room SYD-03 (Max: N...
- Laboratory SYD-04 (Max...
- Laboratory SYD-05 (Max...
- Laboratory SYD-06 (Max...

Buttons: Cancel, Save and Update Schedules, Save





RIO Education Data Model v2.9

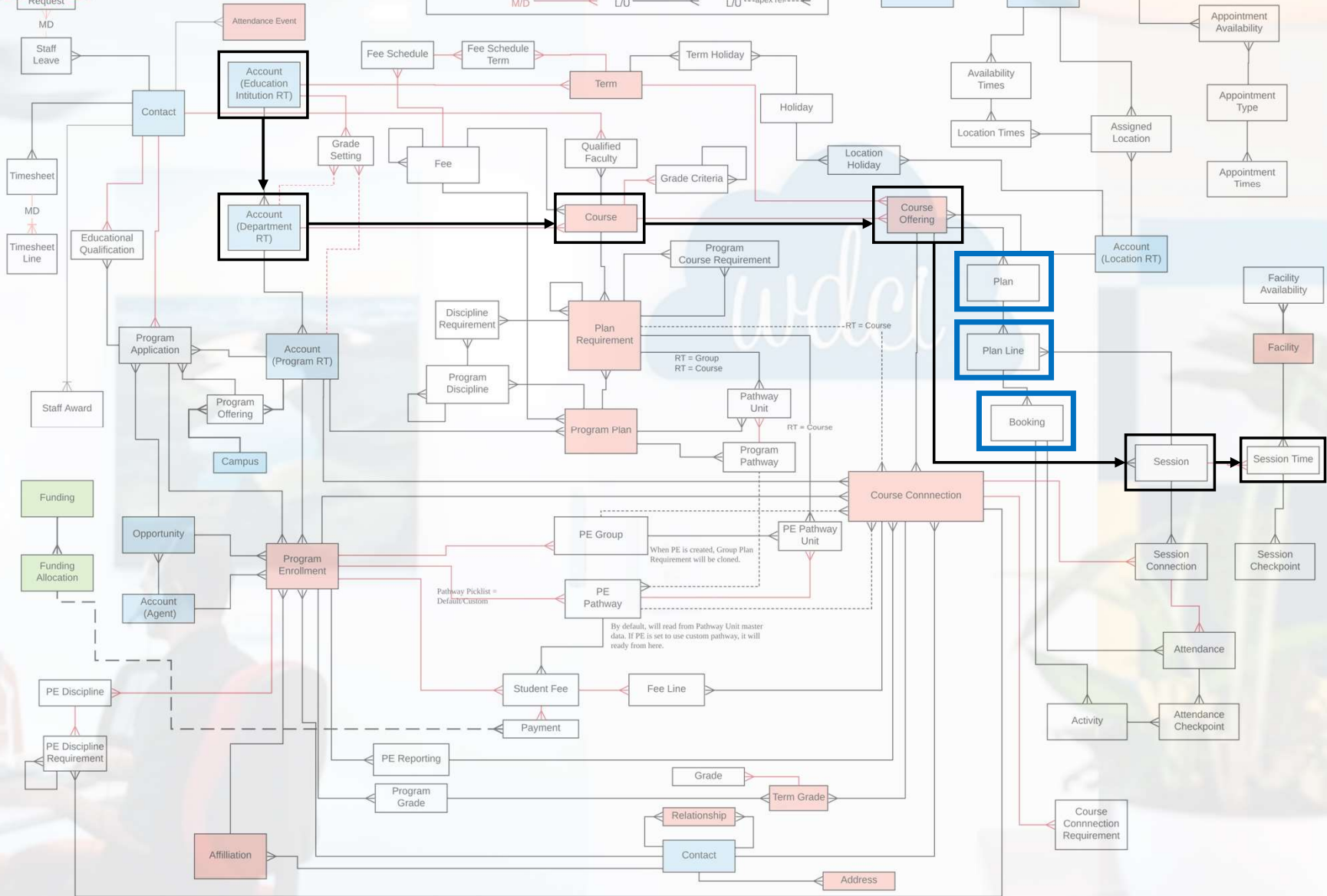
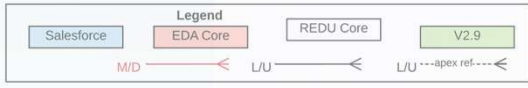

Now,  
What is all this  
stuff?

These objects  
are intended  
for the  
**Session  
Scheduler**







RIO Education Data Model v2.9

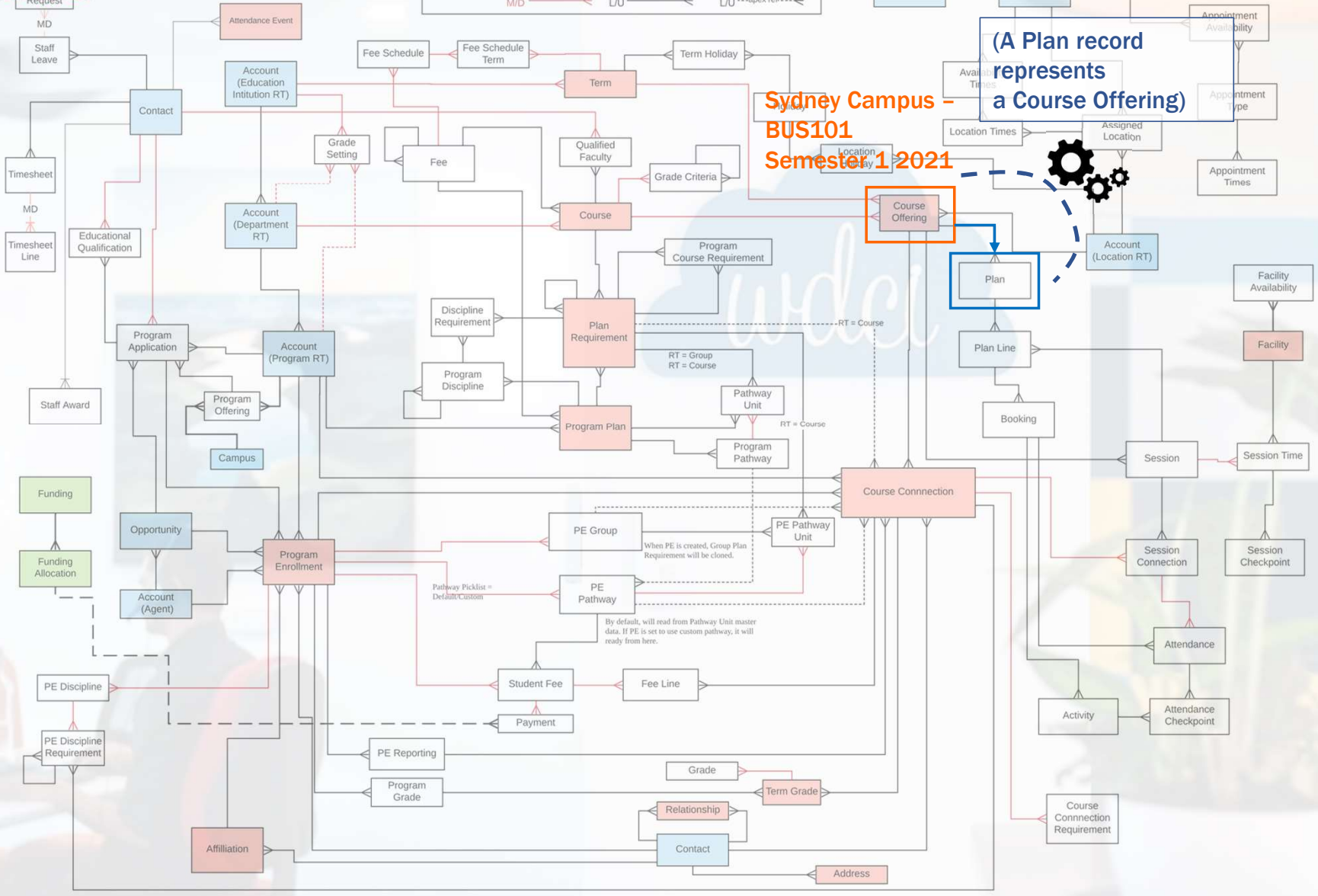
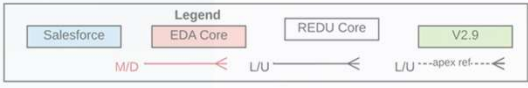

Every academic term, a System Administrator must create a new **COURSE OFFERING**

And every time a new Course Offering is created, a **PLAN** record is created automatically





RIO Education Data Model v2.9

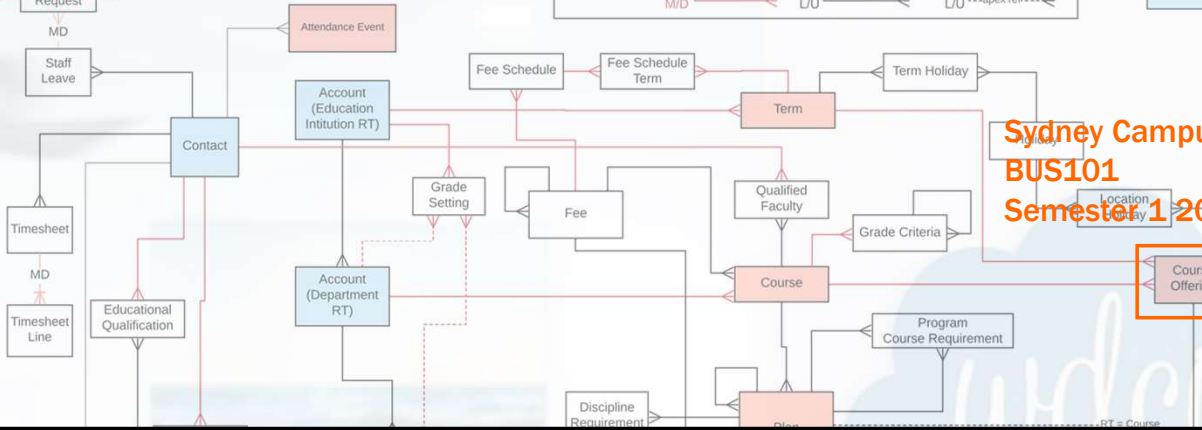
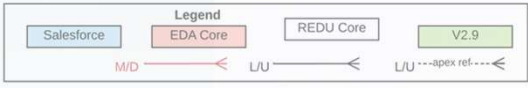

Sydney Campus -  
BUS101  
Semester 1 2021

(A Plan record represents a Course Offering)

(A Plan Line record represents a Session)

**Session Time**  
ST-2453

Day of week	Start Date	End Date	Start Time	End Time
Friday	1/03/2021	29/06/2021	13:00	15:00

Session Time	ST-2453	Status	Active
Session	BUS101 Lecture	Start Time	13:00
Facility	Room SYD-03	End Time	15:00
Day of week	Friday	Timezone	Australia/Sydney
Recurrence	Weekly	Start Date	1/03/2021
Label	Friday, 13:00-15:00	End Date	29/06/2021
Ignore Holidays	<input type="checkbox"/>		

▼ Create/Update Settings

Create/Update Settings: Create/Update after today

Created By: Adam Administrator, 12/01/2021 1:14 PM

Booking Change Date: [icon]

Last Modified By: Adam Administrator, 19/05/2021 11:17 AM

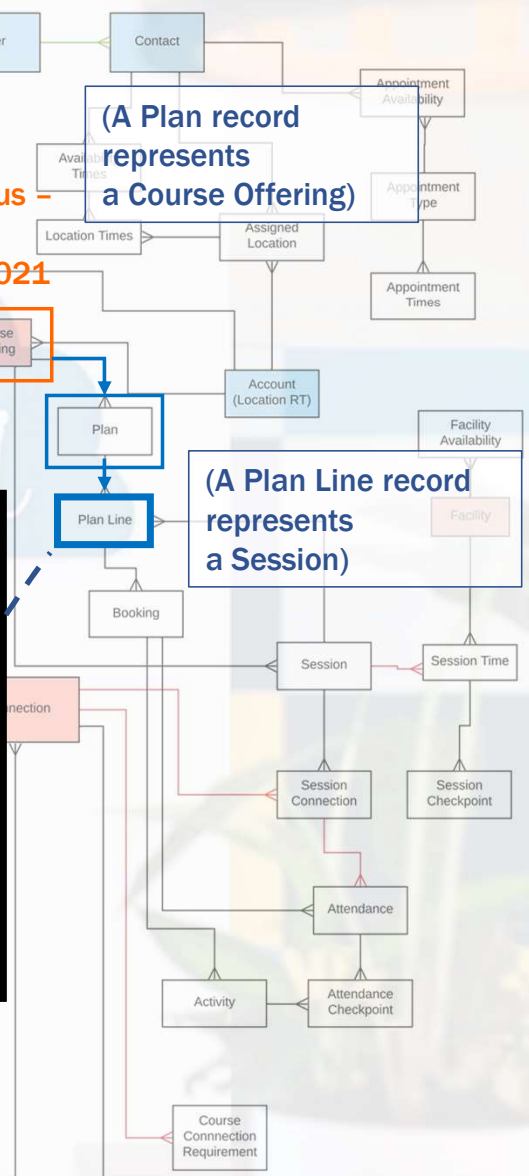

Every time a Session gets updated with a Session Time,

a Plan Line record is created





RIO Education Data Model v2.9

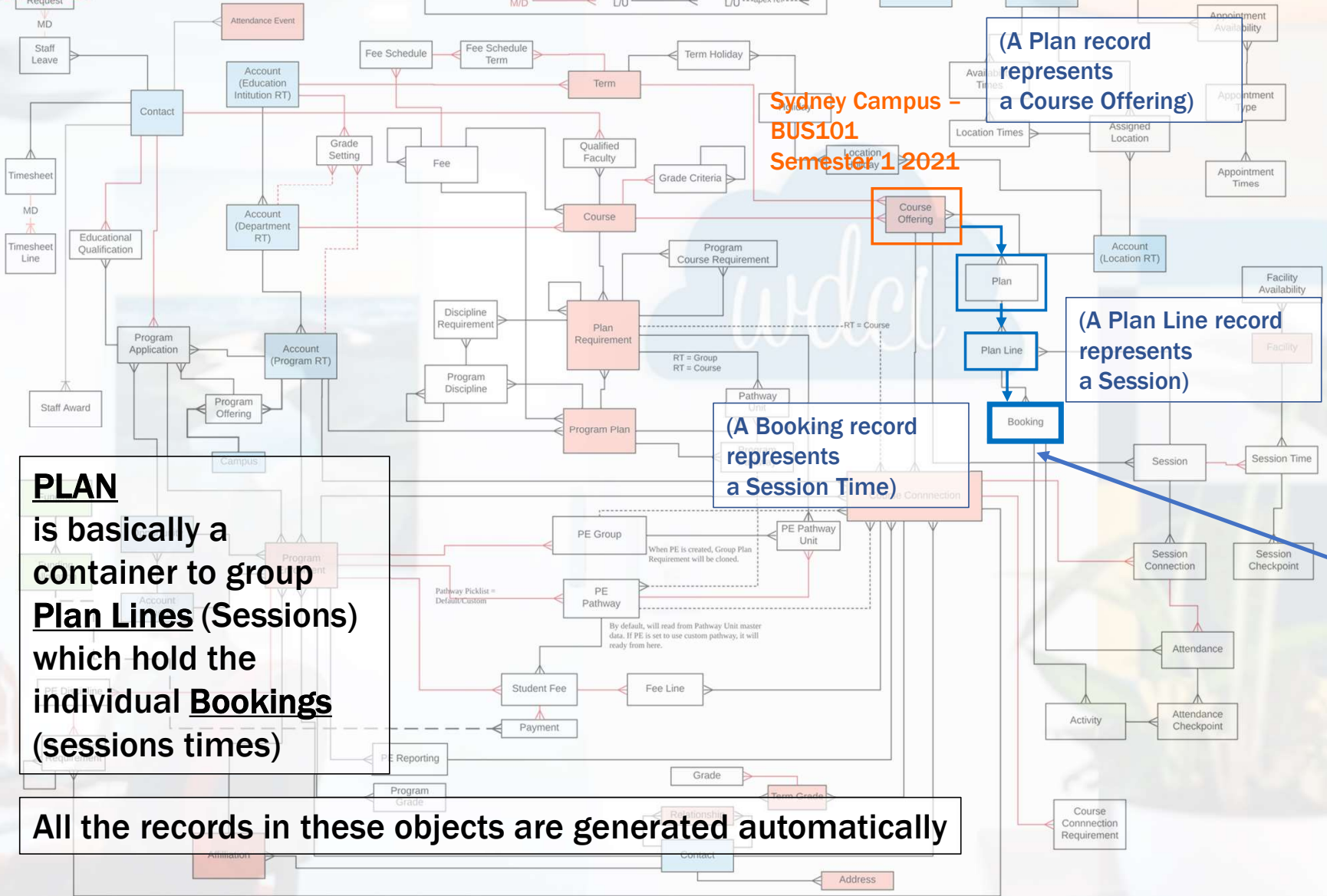
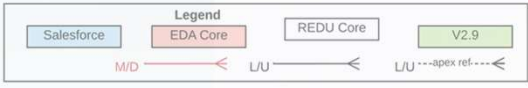

Sydney Campus - BUS101 Semester 1 2021

(A Plan record represents a Course Offering)

(A Plan Line record represents a Session)

(A Booking record represents a Session Time)

**PLAN** is basically a container to group **Plan Lines (Sessions)** which hold the individual **Bookings (sessions times)**

All the records in these objects are generated automatically

And each **Plan Line** record will have as many **Booking** records as **Time Sessions** are scheduled

These individual bookings are what will display on the **Student and Faculty Session** calendars



*wdci*

Introduction to RIO Education:

# **(Rules for) Program Progression**







RIO Education Data Model v2.9

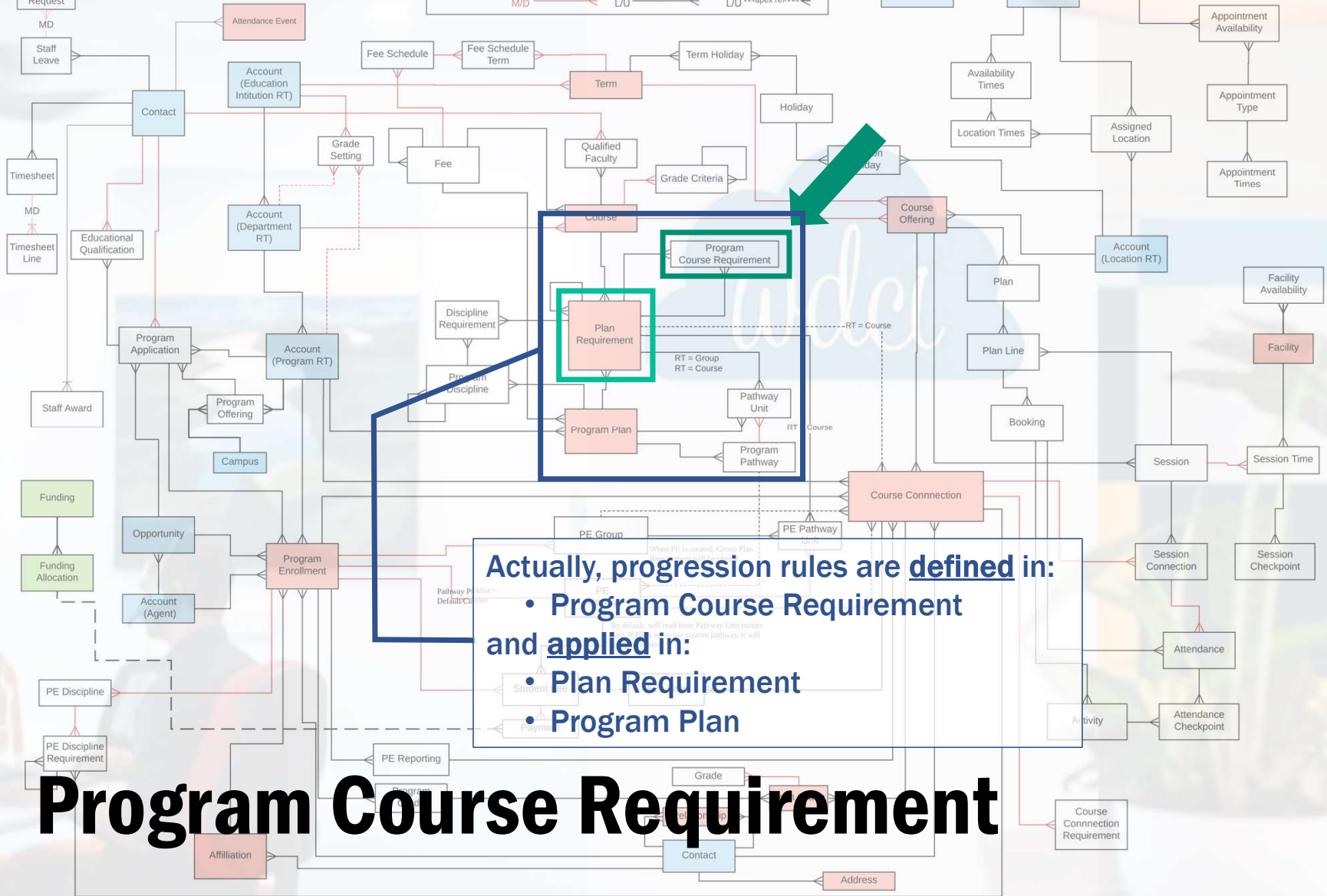
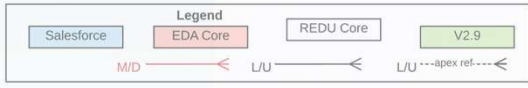

Actually, progression rules are defined in:

- Program Course Requirement

and applied in:

- Plan Requirement
- Program Plan

# Program Course Requirement

## Plan Requirement

collects the most basic set of requirements (i.e. the Courses) a student must meet in order to progress through the Program.

However, it does not set out the rules to meet in order to keep enrolling Courses.

Program Course Requirement does





31 Items • Sorted by Record Type • Updated a few seconds ago

<input type="checkbox"/>	Plan Requirement Name	Record Type	Parent Plan Requirement	Unit	Category	Credits	AI...	Requirement Description
<input type="checkbox"/>	RIOUNI02-Mandatory	Group			Required	160.000	<input type="checkbox"/>	
<input type="checkbox"/>	RIOUNI02-Electives	Group			Required	80.000	<input type="checkbox"/>	
<input type="checkbox"/>	Internship	Group			Required	40.000	<input type="checkbox"/>	
<input type="checkbox"/>	RIOUNI022018 - BUS101	Unit	RIOUNI02-Mandatory	BUS101: Business Analytics	Required	10.000	<input type="checkbox"/>	
<input type="checkbox"/>	RIOUNI022018 - BUS102	Unit	RIOUNI02-Mandatory	BUS102: Introduction to Economics	Required	10.000	<input type="checkbox"/>	
<input type="checkbox"/>	RIOUNI022018 - BUS104	Unit	RIOUNI02-Mandatory	BUS104 Introduction to Management	Required	10.000	<input type="checkbox"/>	No pre-requisites required
<input type="checkbox"/>	RIOUNI022018 - BUS105	Unit	RIOUNI02-Mandatory	BUS105 Introduction to Marketing	Required	10.000	<input type="checkbox"/>	BUS101 must be completed as a pre-requisite
<input type="checkbox"/>	RIOUNI022018 - BUS106	Unit	RIOUNI02-Mandatory	BUS106 Accounting for Business	Required	10.000	<input type="checkbox"/>	BUS101 must be completed as a pre-requisite
<input type="checkbox"/>	RIOUNI022018 - BUS108	Unit	RIOUNI02-Mandatory	BUS108 Introduction to Informatics	Required	10.000	<input type="checkbox"/>	
<input type="checkbox"/>	RIOUNI022018 - BUS203	Unit	RIOUNI02-Mandatory	BUS203 Business Law and Ethics	Required	10.000	<input type="checkbox"/>	
<input type="checkbox"/>	RIOUNI022018 - BUS211	Unit	RIOUNI02-Mandatory	BUS211 Strategic Management	Required	10.000	<input type="checkbox"/>	BUS104 must be completed as a pre-requisite
<input type="checkbox"/>	RIOUNI022018 - BUS301	Unit	RIOUNI02-Electives	BUS301 Business Analytics 2	Optional	10.000	<input type="checkbox"/>	BUS101 must be completed as a pre-requisite
<input type="checkbox"/>	RIOUNI022018 - BUS320	Unit	RIOUNI02-Electives	BUS320 Corporate Governance and Social Responsibility	Optional	10.000	<input type="checkbox"/>	
<input type="checkbox"/>	RIOUNI022018 - COR109	Unit	RIOUNI02-Electives	COR109 Communication and Thought	Optional	10.000	<input type="checkbox"/>	
<input type="checkbox"/>	RIOUNI022018 - HRM311	Unit	RIOUNI02-Electives	HRM311 Leadership and Team Dynamics	Optional	10.000	<input type="checkbox"/>	
<input type="checkbox"/>	RIOUNI022018 - HRM321	Unit	RIOUNI02-Electives	HRM321 Managing Organisational Change	Optional	10.000	<input type="checkbox"/>	
<input type="checkbox"/>	RIOUNI022018 - IBS220	Unit	RIOUNI02-Electives	IBS220 Cross-Cultural Management	Optional	10.000	<input type="checkbox"/>	
<input type="checkbox"/>	RIOUNI022018 - ICT112	Unit	RIOUNI02-Mandatory	ICT112 Creative Problem Solving with Programming	Required	10.000	<input type="checkbox"/>	
<input type="checkbox"/>	RIOUNI022018 - ICT115	Unit	RIOUNI02-Mandatory	ICT115 Introduction to Systems Design	Required	10.000	<input type="checkbox"/>	
<input type="checkbox"/>	RIOUNI022018 - ICT120	Unit	RIOUNI02-Electives	ICT120 Introduction to Telecommunications and Networks	Optional	10.000	<input type="checkbox"/>	
<input type="checkbox"/>	RIOUNI022018 - ICT211	Unit	RIOUNI02-Mandatory	ICT211 Database Design	Required	10.000	<input type="checkbox"/>	BUS108 must be completed as a pre-requisite
<input type="checkbox"/>	RIOUNI022018 - ICT221	Unit	RIOUNI02-Mandatory	ICT221 Software Development 1	Required	10.000	<input type="checkbox"/>	Both ICT112 and ICT115 must be completed
<input type="checkbox"/>	RIOUNI022018 - ICT310	Unit	RIOUNI02-Mandatory	ICT310 Systems Analysis and Design	Required	10.000	<input type="checkbox"/>	Either (ICT112 or ICT221) must be completed
<input type="checkbox"/>	RIOUNI022018 - ICT320	Unit	RIOUNI02-Mandatory	ICT320 Database Programming	Required	10.000	<input type="checkbox"/>	Both ICT112 and ICT115 must be completed
<input type="checkbox"/>	RIOUNI022018 - ICT330	Unit	RIOUNI02-Electives	ICT330 ICT Business Management	Optional	10.000	<input type="checkbox"/>	Must be approved by course coordinator before enrolment
<input type="checkbox"/>	RIOUNI022018 - ICT335	Unit	RIOUNI02-Mandatory	ICT335 ICT Business Management	Required	10.000	<input type="checkbox"/>	Either ICT211 or ICT221 must be completed as a pre-requisite

# Program Course Requirements in action



In Program Course Requirements is were rules are defined

(‘Course’ = ‘Unit’ in Australia)

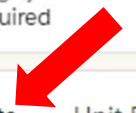

Program Unit Requirements (2) New

Program Unit Requirement Name	Requirement ID	Requirement Type	Unit
<a href="#">RIOUNI02 - ICT221:ICT112</a>	A	Pre-Requisite	<a href="#">ICT112 Creative Problem Solving with Programming</a>
<a href="#">RIOUNI02 - ICT221:ICT115</a>	B	Pre-Requisite	<a href="#">ICT115 Introduction to Systems Design</a>

[View All](#)

# Program Course Requirements in action



Plan Requirement  
RIOUNI022018 - ICT221

In Plan Requirement is were rules are applied

Program Plan  
Bachelor of Business Information System V1

Category  
Required

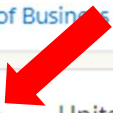

Details Units Program Unit Requirements Unit Enrollments

Information

Plan Requirement Name	RIOUNI022018 - ICT221	Owner	Amy Adams
Program Plan	Bachelor of Business Information System V1	Record Type	Unit
Parent Plan Requirement	RIOUNI02-Mandatory	Category	Required
Unit	ICT221 Software Development 1	Credits	10.000
Description		EFTSL	
		Sequence	

Requirement Information

Requirement Description	Both ICT112 and ICT115 need to be completed as a pre-requisite to enrol in this course.	Allow Pre-Enrollment?	<input type="checkbox"/>
Requirement Logic	A AND B		

System Information

Created By Adam Administrator, 5/11/2018 6:22 PM

Last Modified By Adam Administrator, 30/06/2020 4:53 PM

# Program Course Requirements in action



Plan Requirement  
RIOUNI022018 - ICT221

Program Plan  
Bachelor of Business Information System V1

Category  
Required

- Details
- Units
- Program Unit Requirements
- Unit Enrollments

Information

Plan Requirement Name	RIOUNI022018 - ICT221	Owner	Amy Adams
Program Plan	Bachelor of Business Information System V1	Category	Required
Parent Plan Requirement	RIOUNI02-Mandatory	Unit	ICT221 Software Development 1
Unit	ICT221 Software Development 1	EFTSL	
Description		Sequence	

Now, some additional rules are also applied at the Program Plan level

Requirement Information

Requirement Description	Both ICT112 and ICT115 need to be completed as a pre-requisite to enrol in this course.	Allow Pre-Enrollment?	<input type="checkbox"/>
Requirement Logic	A AND B		

System Information

Created By Adam Administrator, 5/11/2018 6:22 PM  
Last Modified By Adam Administrator, 30/06/2020 4:53 PM

Progression rules in action



Start Date 1/01/2018 End Date

These rules are applied here because they are not Course-specific

- Details
- Program Structure
- Pathways
- Program Enrollments
- Program Disciplines

Information			
Program Plan Name	Bachelor of Business Information System V1	Owner	Amy Adams
Account	Bachelor of Business Information System	Status	Current
Start Date	1/01/2018	Version	V.1.0
End Date		Is Primary	<input checked="" type="checkbox"/>
Description	Program Plan for year 2018 onward	Auto Credit Transfer	<input type="checkbox"/>
Next Starting Term	Semester 2 2020		
Sponsor	WDCi Group		
Program Information			
Dual Qualification	<input type="checkbox"/>	Primary Program	
		Secondary Program	
Fees			
Fee Method	Term	Current Fee (Domestic)	\$10,000.00
Pay Upfront	No	Current Non Tuition Fee (Domestic)	\$1,250.00
		Current Fee (International)	\$14,000.00
Fee	Band 3 - Program	Current Non Tuition Fee (International)	\$1,550.00
Use Default Fee	<input type="checkbox"/>		
Progression Rules			
Progression Rules	Standard	Min Passed %	50%
Progression Terms	2	Min GPA	2.500
Custom Rule Description		Use Unit Minimum?	<input type="checkbox"/>





Progression rules:

Now, bear in mind:

**This is just the way generic rules are set in a specific Program Plan**

**However, students may have their own rules.**

**This is why Program Course Requirement is a template only**





RIO Education Data Model v2.9

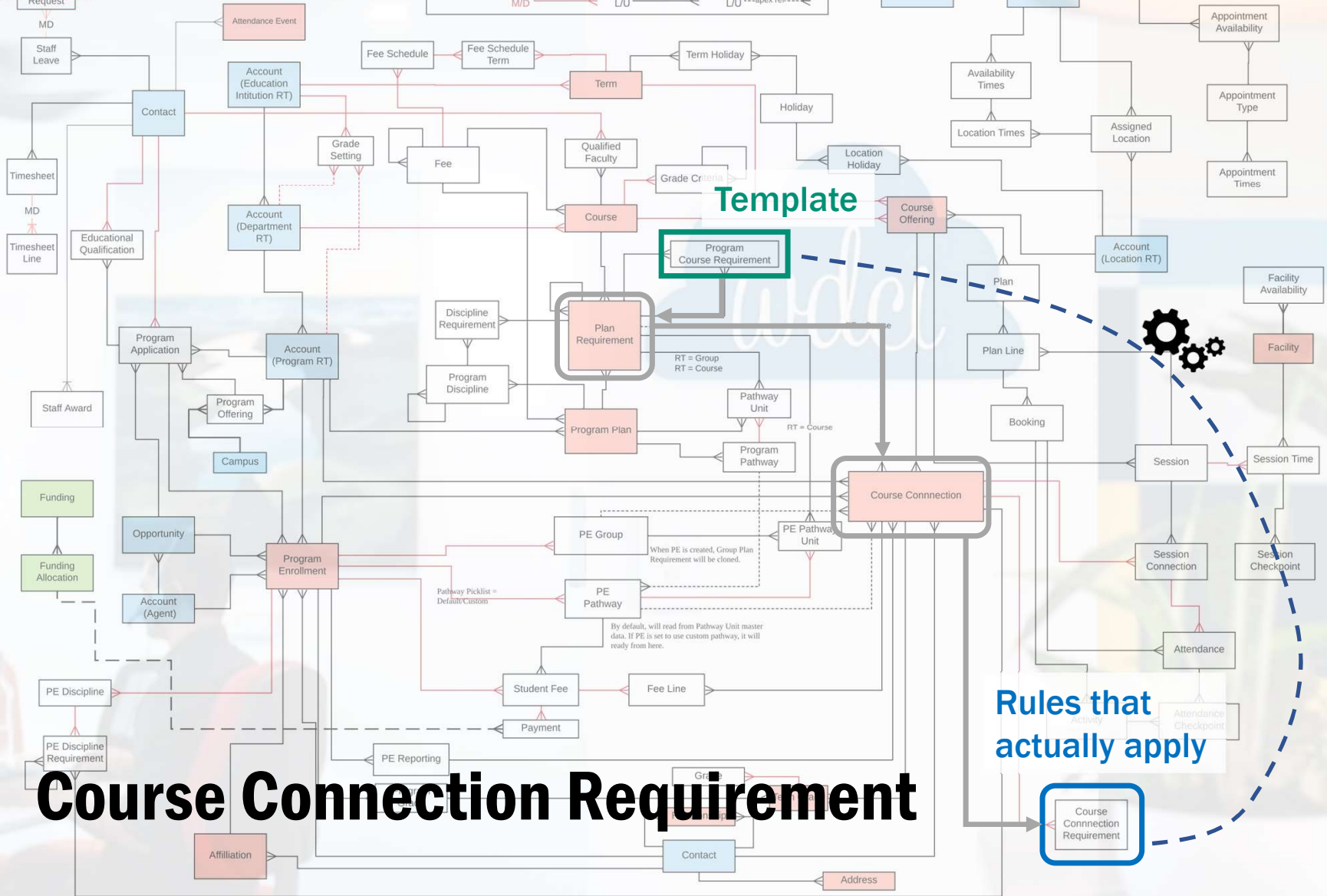
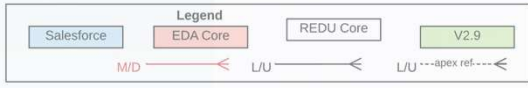

# Course Connection Requirement

With every new Course Connection...

Program Course Requirement get cloned...

into a new record in Course Connection Requirement

Hence, the progression rules that apply to a student are those ones in Program Course Requirement at the time the student enrolled in the Program.

Rules that actually apply



# wdci

Introduction to RIO Education:

## Fees

The Cloud Solutions Company

wdci





RIO Education Data Model v2.9

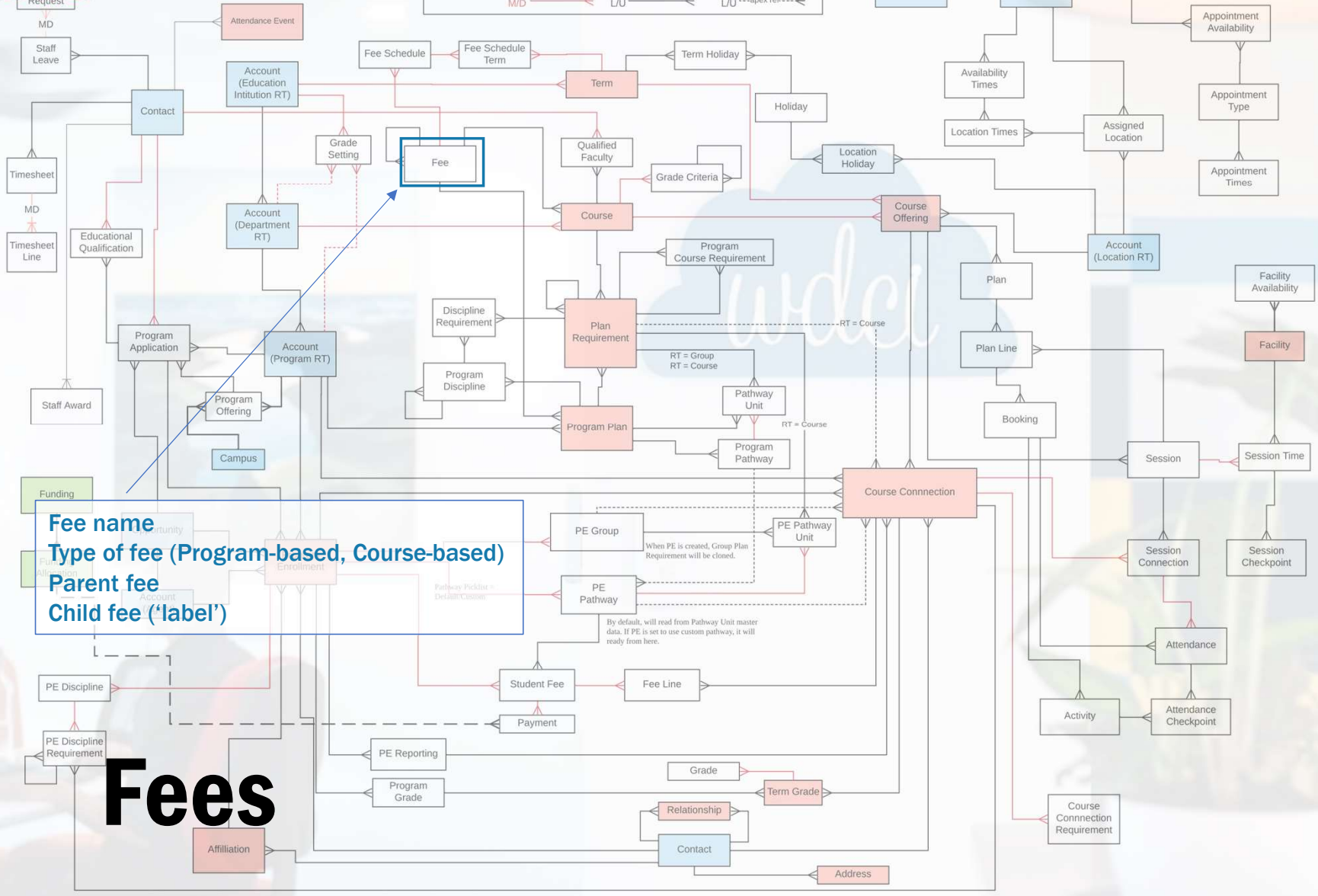
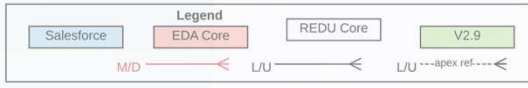

**Fee name**  
**Type of fee (Program-based, Course-based)**  
**Parent fee**  
**Child fee ('label')**

# Fees

## Fees

are set independently from Courses and Programs, then linked to them appropriately

The **FEE OBJECT**, contains information about the different types of fees the institution applies







RIO Education Data Model v2.9

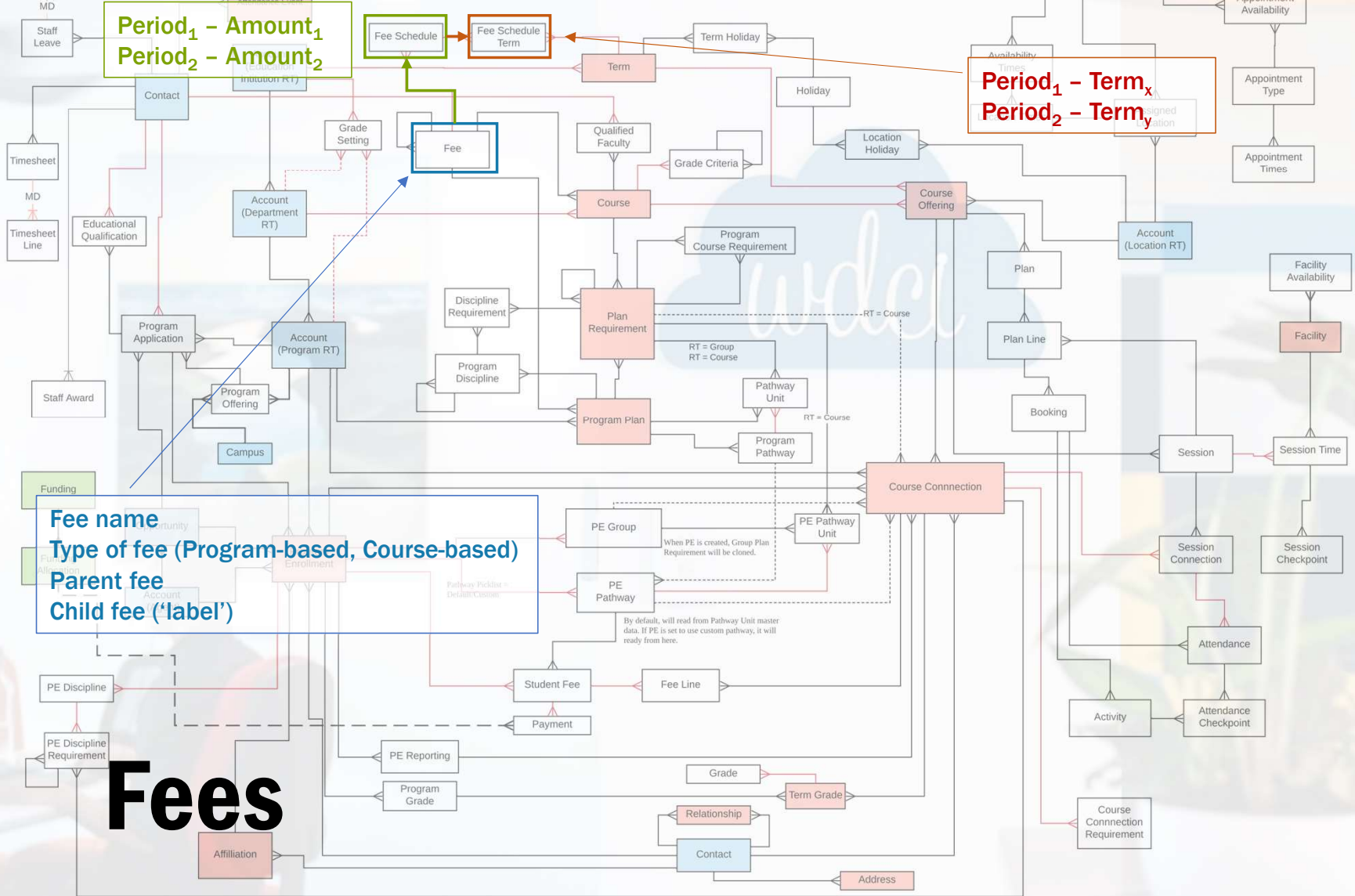
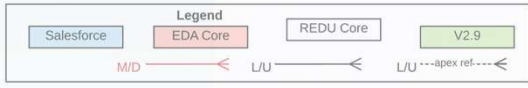

Period<sub>1</sub> - Amount<sub>1</sub>  
 Period<sub>2</sub> - Amount<sub>2</sub>

Period<sub>1</sub> - Term<sub>x</sub>  
 Period<sub>2</sub> - Term<sub>y</sub>

Fee name  
 Type of fee (Program-based, Course-based)  
 Parent fee  
 Child fee ('label')

# Fees

## Fees

The **FEE** object, contains information about the different types of fees the institution applies

For each fee, the **FEE SCHEDULE** object, contains information about the amount of the fee over a time period

For each period, the **FEE SCHEDULE TERM** object, specifies which term each period corresponds to





Fee Unit indicates the 'entity' this Fee applies to. Options:

- None--
- EFTSL
- Unit
- Program
- Year
- Term
- Credit

Fee Band 3 - Program

Details Fee Schedules Units Child Fees

Fee Name	Band 3 - Program	Current Fee (Domestic)	\$10,000.00
Fee Type	Tuition	(Obsolete)Cur. Non Tuition Fee(Domestic)	\$1,250.00
<b>Fee Unit</b>	<b>Program</b>	Current Fee (International)	\$14,000.00
Loan Fee %	0.00%	(Obsolete)Current Non Tuition Fee(Int'l)	\$1,550.00

Grouping

Parent Fee

**Fee Label**

Other Information

Description: Law, dentistry, medicine, veterinary science, accounting, administration, economics, commerce.

**Note:**  
Fee Unit indicates to which 'entity' the fee relates. It is an equivalent to 'Relates to:'  
Fee Method (later) will indicate whether the we are actually applying the fee or not.

This is to identify the child fee within a group of fees; for example: Discounted fee for 'Online' study mode

# Example of a fee



Field Name	Description
Fee Type	Identify the type of fee. This is not being utilized in automation at the moment.
Fee Unit	<p>The automation in RIO Education is only using Course and Program fee unit at the moment.</p> <p>The fee record with "Fee Unit" = Course is used by Course.</p> <p>The fee record with "Fee Unit" = Program is used by Program Plan.</p>
Loan Fee %	This is the additional interest charges imposed by an educational institution when a student chooses to pay the tuition fee using government loan (VET Student Loan/Fee Help).
Parent Fee	<p>This is to group fees and it is used in conjunction with Fee Label in the automation of defining fee for:</p> <ul style="list-style-type: none"> <li>- Course Offering</li> <li>- Program Enrollment</li> </ul>

Fee Label	This is to identify the child fee within a group of fees. This is used to set a different fee to a Program or course that may be delivered via a different method. E.G BUS101 Course may be \$1000 for the default fee, but a child fee of \$500 may be available for online study. The Fee label would be "Online"
Current Fee (Domestic & International)	For display purpose only. The value is rolled up from a child fee schedule record if the child fee schedule is marked as "Current" = checked.
Current Non Tuition Fee (Domestic & International)	For display purpose only. The value is rolled up from a child fee schedule record if the child fee schedule is marked as "Current" = checked.
Discountable	Can be discounted by discount type Funding Allocations
Non-repeatable	A student will only get a fee line for this fee once, even if enrolling in multiple courses that all have

# Fee: Important fields

You may find a table like this per each Fee-related object in our Technical Documentation for Partners guide.





RIO Education Data Model v2.9

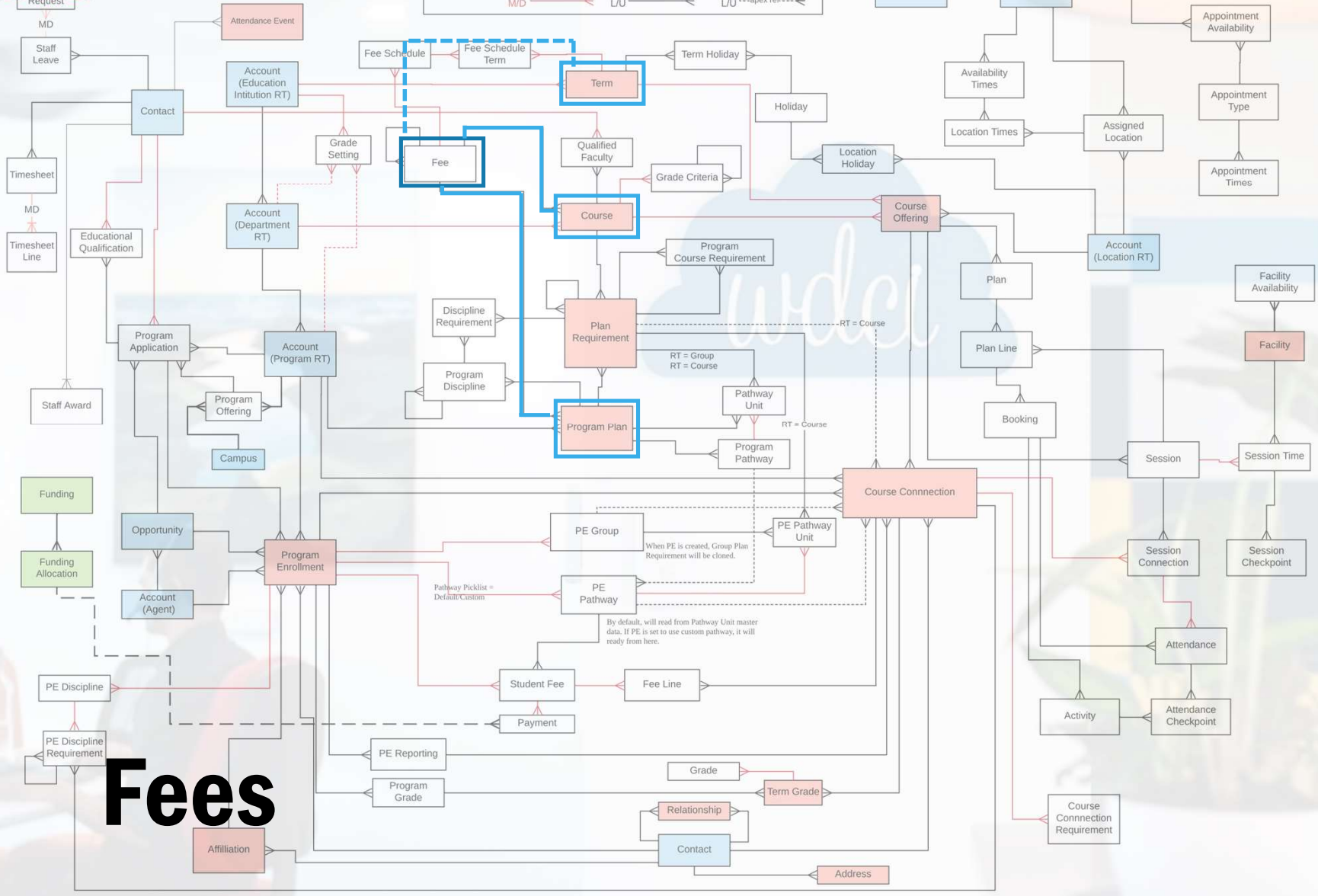
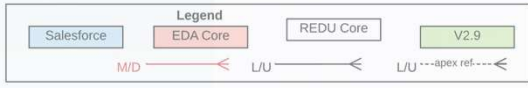

# Fees

**FEES**  
are set either at Course  
or at Program Plan  
level

Indirectly, Fees are also linked to Terms through *Fee Schedule* and *Fee Schedule Term* objects





RIO Education Data Model v2.9

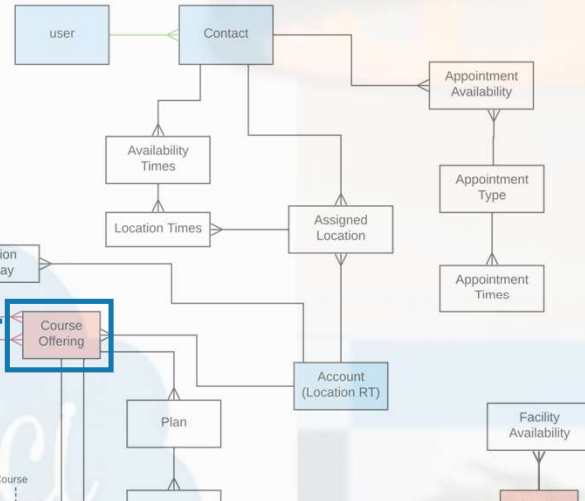
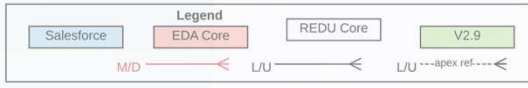

If we have set up fees at **Course level**, every time we create a new **Course Offering**, the automation will pick the fee linked to the term and will apply it.



However, we do have the option to **manually select a different fee** in a Course Offering

**1**

Unit **BUS101: Business Analytics**

Unit ID: BUS101, Department: School of Business, Credit Hours: 10.000

Details: Unit Offerings, Qualified Faculty, Academic Programs, Grade Criteria, Session Templates

Unit Name: BUS101: Business Analytics, Department: School of Business, Estimated EFTSL: 0.125

Fee Information: Fee: **Band 3 - Unit**

**4**

Fee Schedule **Band 3 - Course: 2019**

Details: **Fee Schedule Terms**

Fee Schedule Terms (2)

Fee Schedule Term	Term Name	Start Date
FST20190225-9	Semester 1 2019	1/03/2019
FST20190225-10	Semester 2 2019	31/08/2019

**3**

Fee **Band 3 - Unit**

Details: **Fee Schedules**

Fee Schedules (4)

Fee Schedule Name	Fee Start Date	Fee End Date	Current	Fee Amount	Fee Amount
Band 3 - Course: 2021	1/01/2021	31/12/2021		\$600.00	\$1,000.00
Band 3 - Course: 2020	1/01/2020	31/12/2020	<input checked="" type="checkbox"/>	\$343.75	\$468.75
<b>Band 3 - Course: 2019</b>	<b>1/01/2019</b>	<b>31/12/2019</b>	<input type="checkbox"/>	<b>\$313.50</b>	<b>\$437.50</b>
Band 3 - Course: 2018	1/01/2018	31/12/2018		\$312.50	\$437.50

**2**

Fee **Band 3 - Unit**

Details: Fee Schedules, Units, Child Fees

Fee Name: Band 3 - Unit, Fee Type: Tuition, Fee Unit: **Unit**

# Fees: Course-level fees





Start Date  
1/01/2018

Details Program Structure Pathways Program Enroll

> Information

> Program Information

Fee  
**Band 3 - Program**

Details **Fee Schedules** Units Child Fees

**Fee Schedules (3)**  
3 items • Updated a few seconds ago

<input type="checkbox"/>	Fee Schedule Name	Fee Start D...	Fee End Date	Current	Fee Amou...	Fee Amou...
1	<input type="checkbox"/> Band 3 - Program: 2022	1/01/2022	31/12/2023	<input type="checkbox"/>	\$11,000.00	\$15,000.00
2	<input type="checkbox"/> Band 3 - Program: 2019	1/01/2019	31/12/2021	<input checked="" type="checkbox"/>	\$10,000.00	\$14,000.00
3	<input type="checkbox"/> Band 3 - Program: 2018	1/01/2018	31/12/2018	<input type="checkbox"/>	\$9,000.00	\$13,500.00

[View All](#)

<b>FEE</b>		<b>FEE SCHEDULE</b>	
Fee Method	Program	Current Fee (Domestic)	\$10,000.00
Pay Upfront	No	Current Non Tuition Fee (Domestic)	\$1,250.00
Fee ⓘ	Band 3 - Program	Current Fee (International)	\$14,000.00
Use Default Fee	<input type="checkbox"/>	Current Non Tuition Fee (International)	\$1,550.00

> Progression Rules

> System Information

# Fees: Program-level fees





Fee Method	Program
Pay Upfront	No
Fee	Band 3 - Program
Use Default Fee	<input type="checkbox"/>

## Question for you...

### So then, can we only apply one fee to a Program?

**Answer:**

**We can only apply one DEFAULT fee to a Program but as many student-specific ones as we need to.**

**(within each Program Enrollment, which is what really dictates the fee that actually applies to the student)**

## Fees: Program-level fees



**By setting up:**

- **Fee**
- **Fee Schedule**
- **Fee Schedule Term**

**and setting up the fees that apply at Program level and Course level (if at all), we have created a default fee structure.**

**Fees**



Program Plan  
**Bachelor of Business Information Systems**

Start Date 1/01/2018

Details **Program Structure** Pathways Program Enrollments Program Disciplines

> Information

> Program Information

1. Program-level default fee

Fee Method	Term - Course	Current Fee (Domestic)	\$10,000.00
Pay Upfront	No	Current Non Tuition Fee (Domestic)	\$1,250.00
Fee	Band 3 - Program	Current Fee (International)	\$14,000.00
		Current Non Tuition Fee (International)	\$1,550.00

Use Default Fee

Program Plan  
**Bachelor of Business Information Systems**

Start Date 1/01/2018

Details **Program Structure** Pathways Program Enrollments Program Disciplines

Plan Requirements (6+)

Plan Requirement Name	Record Type	Parent Plan Requirement	Unit
RIOUNI02-Mandatory	Group		
RIOUNI02-Electives	Group		
RIOUNI022018 - BUS101	Unit	RIOUNI02-Mandatory	BUS101: Business Analytics
RIOUNI022018 - BUS102	Unit	RIOUNI02-Mandatory	BUS102: Introduction to Economics
RIOUNI022018 - BUS104	Unit	RIOUNI02-Mandatory	BUS104 Introduction to Management
RIOUNI022018 - BUS105	Unit	RIOUNI02-Mandatory	BUS105 Introduction to Marketing

View All

Unit Offering  
**Sydney Campus - BUS101 Semester 2 2019**

Unit BUS101: Business Analytics Start Date 31/08/2019 Primary Faculty Fran Fisher Capacity 40

Details Sessions Students Faculty

Unit	Term
BUS101: Business Analytics	

Unit Offering ID	Campus
Sydney Campus - BUS101 Semester 2 2019	

Unit Delivery Method	Section ID
Classroom	

3. Course Offering default fee

Fee Label	Fee Amount (Domestic)	\$313.50	
Fee	Band 3 - Unit	Fee Amount (International)	\$437.50

Manual Fee Selection

Unit  
**BUS101: Business Analytics**

Unit ID BUS101 Department School of Business Credit Hours 10,000

Details **Unit Offerings** Qualified Faculty Academic Programs

Unit Offerings (6+)

Unit Offering: Unit Offering ID	Section ID
Sydney Campus - BUS101 Semester 2 2023	
Sydney Campus - BUS101 Semester 2 2022	
Sydney Campus - BUS101 Semester 2 2021	
Sydney Campus - BUS101 Semester 2 2020	
Sydney Campus - BUS101 Semester 2 2019	
Sydney Campus - BUS101 semester 2 2018	

Unit  
**BUS101: Business Analytics**

Unit ID BUS101 Department School of Business Credit Hours 10,000

Details **Unit Offerings** Qualified Faculty Academic Programs Grade Criteria Session Templates

Unit Name	Unit ID
BUS101: Business Analytics	BUS101

Department	Credit Hours
School of Business	10,000

Estimated EFTSL	Credit Points
0.125	10,000

2. Course-level default fee

Fee	Band 3 - Unit	Current Fee (Domestic)	\$600.00
Use Default Fee	<input checked="" type="checkbox"/>	Current Fee (International)	\$1,000.00

# Fees: The basic (default) fee structure



Application **Sofia Student**

Submitted | Qualified | Awaiting Do... | Letter of Off... | Accepted | Approved | Waitlist | Rejected | Cancelled

Status: Submitted Mark Status as Complete

**Guidance for Success**  
Woohoo! The applicant has submitted the application. Let's proceed to next step to qualify them.

**Details** | Educational Qualifications | History | Evaluations

Applicant	Sofia Student	Status	Submitted
Application ID	PA-00273	Program	Bachelor of Music Performance and Marketing
Status Date	13/03/2021 3:09 AM	Study Mode	Full-time
Lead		Start Month	January
Opportunity		Start Year	2021
Starting Term			
Default Campus			
Program Offering			

Payment Information

Fee Method	Term - Course	Fee Label	
Pay Upfront	No		
Fee Type	Self Paid		
Fee Type Option			

## As early as at Program Application,

Administrators can specify a **FEE METHOD** for the student. This is an optional setting that is applied manually by the Admin.

If the student completes enrollment and no Fee Method is selected, the Program's default fee method will apply.

**Fee Method:**  
Determines if the student will be paying by program, term or course.

When "Auto Program Enrollment" is enabled, this will be taken to the student's PROGRAM ENROLLMENT record.

# Fees: Overriding the default fee structure



# As early as at Program Application,

Program Plan  
**Bachelor of Business Information System V1**

Start Date: 1/01/2018

End Date:

Details | Program Structure | Pathways | Program Enrollments | Program Disciplines

> Information

> Program Information

▼ Fees

Fee Method	Program	Current Fee (Domestic)	\$10,000.00
Pay Upfront	NO	Current Non Tuition Fee (Domestic)	\$1,250.00
Fee	Band 3 - Program	Current Fee (International)	\$14,000.00
Use Default Fee	<input type="checkbox"/>	Current Non Tuition Fee (International)	\$1,550.00

> Progression Rules

> System Information

Program's default fee method

Administrators can specify a **FEE METHOD** for the student. This is an optional setting that is applied manually by the Admin.

If the student completes enrollment and no Fee Method is selected, the Program's default fee method will apply.

**Remember:**  
This will be overridden by any Fee Method specified in the student's PROGRAM ENROLLMENT record.

# Fees: Overriding the default fee structure





**There are 'Fee Method' fields in several objects: Program Application, Program Enrollment, Program Plan, etc. The one that overrides all is the Fee Method in PROGRAM ENROLLMENT.**

Enrollment  
**PE-0025**

Contact	Program	Start Date	GPA
Sarah Smith	Bachelor of Music Performance and Marketing	5/03/2018	4.140

**Details** Pathways Unit Enrollments Student Fees PE Disciplines Program Completion Grades

> Enrollment Detail

∨ Fees

∨ Fee Information

Fee Label	Program Fee
	\$7,844.75
Fee Label (Override) ⓘ	Paid Amount
	\$1,650.00
<b>Fee Method</b>	Outstanding Amount
<b>Term - Course</b>	-\$1,650.00
Pay Upfront	
No	
Fee Type	
Government Funding	
Fee Type Option	
FEE-HELP	

**Fees: Overriding the default fee structure**



**Program Enrollment contains ALL FEES applied to a student for a specific Program...**

**...including those fees that apply to each COURSE within the Program**

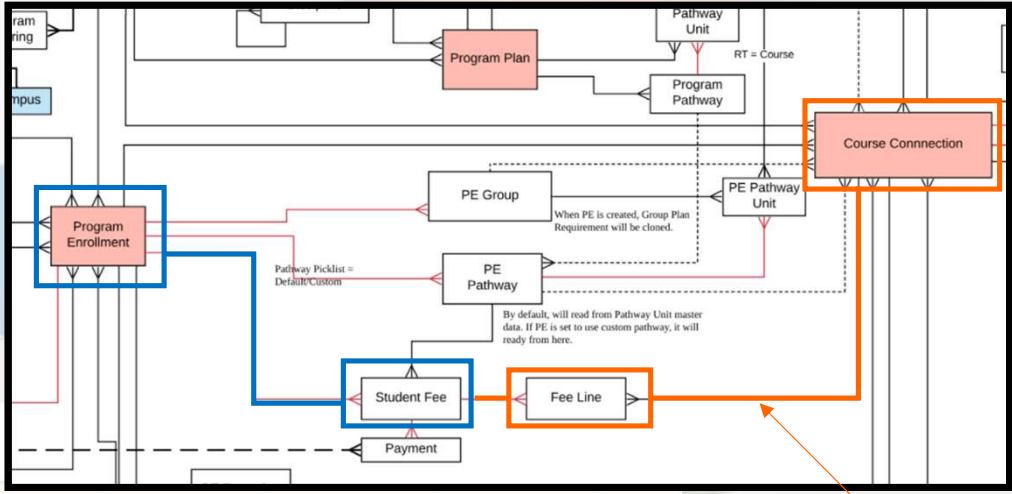

Enrollment PE-0025

Contact	Program	Start Date	GPA
Sarah Smith	Bachelor of Music Performance and Marketing	5/03/2018	4.140

Details Pathways Unit Enrollments **Student Fees** PE Disciplines Program Completion Grades

Student Fees (7)

7 items • Updated a few seconds ago

<input type="checkbox"/>	Student Fee Name	Fee Description	Fee Status	Total Fundin...	Total Upfr...	Total Fee	Total Paid A...	Outstanding ...	Void
<input type="checkbox"/>	F-000000001	Semester 1 2018 Tuition Fees	No payment req...	\$425.00	\$200.00	\$0.00	\$200.00	-\$200.00	<input type="checkbox"/>
<input type="checkbox"/>	F-000000002	Semester 2 2018 Tuition Fees	No payment req...	\$525.00	\$100.00	\$0.00	\$100.00	-\$100.00	<input type="checkbox"/>
<input type="checkbox"/>	F-000000003	Semester 1 2019 Tuition Fees	No payment req...	\$938.50	\$199.00	\$0.00	\$1,350.00	-\$1,350.00	<input type="checkbox"/>
<input type="checkbox"/>	F-000000039		No payment req...	\$1,562.50	\$0.00	\$0.00	\$0.00	\$0.00	<input type="checkbox"/>
<input type="checkbox"/>	F-000000041		No payment req...	\$0.00	\$0.00	\$0.00	\$0.00	\$0.00	<input type="checkbox"/>
<input type="checkbox"/>	F-000000144	Semester 2 2020 Tuition	No payment req...	\$687.50	\$0.00	\$0.00	\$0.00	\$0.00	<input type="checkbox"/>
<input type="checkbox"/>	F-000000229		No payment req...	\$1,000.00	\$0.00	\$0.00	\$0.00	\$0.00	<input type="checkbox"/>

**Note:** Fee Lines can be seen from either the Student Fee or the Course Connection side.

**Fees in action**





RIO Education Data Model v2.9

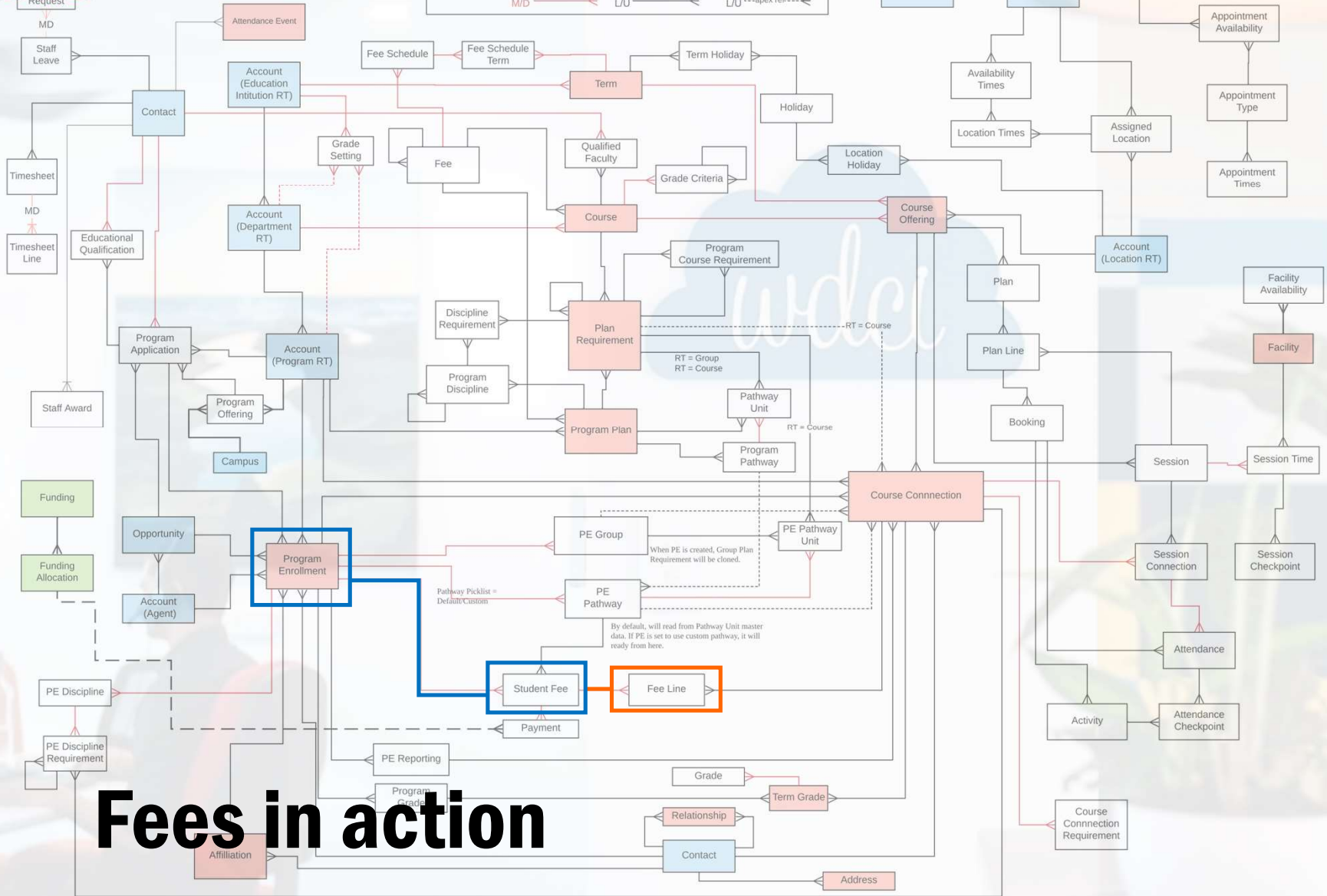
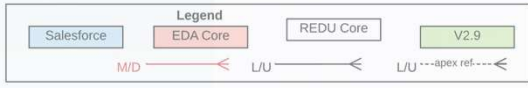

# Fees in action

## Student Fee

Each record in the STUDENT FEE object is a “bundle” of different line items. Student Fee collects all the amounts that are actually applied to a student in relation to a specific Program.

## Fee Line

details, for each Student Fee, the different line items (and their amounts) that add up to such “bundle”.



## FOUR different Fee Methods can be selected:

**Enrollment PE-0535**

Contact	Program	Start Date	GPA
Sofia Student	Bachelor of Music Performance and Marketing		5.380

**Details** | Pathways | Unit Enrollments | Student Fees | PE Disciplines | Program Completion | Grades

> Enrollment Detail

∨ Fees

∨ Fee Information

Fee Label	<i>This field is calculated upon save</i>	Program Fee	\$6,741.25
Fee Label (Override) ⓘ	--None--	Paid Amount	\$900.00 <i>This field is calculated upon save</i>
* Fee Method	Term - Course	Outstanding Amount	\$2,900.00 <i>This field is calculated upon save</i>
* Pay Upfront	--None--		
* Fee Type	Program		
	Course		
	✓ Term - Course		
	Fixed Term		
Fee Type Option	--None--		

View all dependencies

# Fees in action



### Fee Method: Program

 Enrollment <b>PE-0535</b>			
Contact: Sofia Student	Program: Bachelor of Music Performance and Marketing	Start Date:	GPA: 5.380

**ONLY ONE Student Fee record associated with the student's Program Enrollment**

**ONLY ONE Fee Line record associated with the Student Fee record**

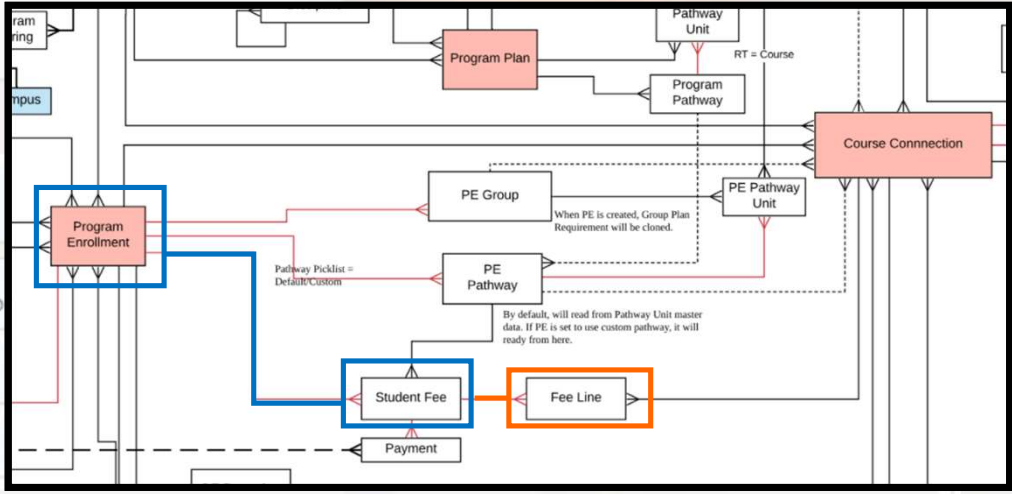

#### Fee Information

Fee Label: *This field is calculated upon save*

Fee Label (Override): --None--

\* Fee Method: **Term - Course**

\* Pay Upfront: **Program**

\* Fee Type: Term - Course

Fee Type Option: --None--

Program Fee	\$6,741.25
Paid Amount	\$900.00 <i>This field is calculated upon save</i>
Outstanding Amount	\$2,900.00 <i>This field is calculated upon save</i>

# Fees in action

**Practical Example:**  
One single invoice with one single line item for the whole Program





### Fee Method: Course

Enrollment PE-0535

Contact: Sofia Student | Program: Bachelor of Music Performance and Marketing | Start Date: | GPA: 5.380

- ONE Student Fee record per each Course Connection
- ONLY ONE Fee Line record associated with each Student Fee record

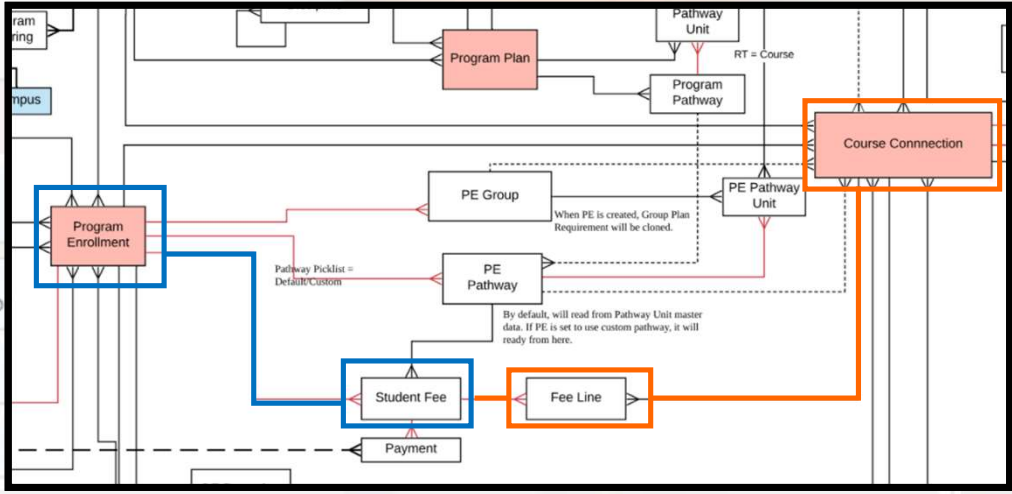

#### Fee Information

Fee Label: *This field is calculated upon save*

Fee Label (Override): --None--

\* Fee Method: **Term - Course**

\* Pay Upfront: Program

\* Fee Type: **Course**

Fee Type Option: --None--

Program Fee	\$6,741.25
Paid Amount	\$900.00 <i>This field is calculated upon save</i>
Outstanding Amount	\$2,900.00 <i>This field is calculated upon save</i>

# Fees in action

Practical Example:  
One invoice with one single line item for every Course the students enrolls in



### Fee Method: Fixed Term

 Enrollment <b>PE-0535</b>			
Contact Sofia Student	Program Bachelor of Music Performance and Marketing	Start Date	GPA 5.380

- ONE Student Fee record per each PE Pathway record
- ONLY ONE Fee Line record associated with each Student Fee record

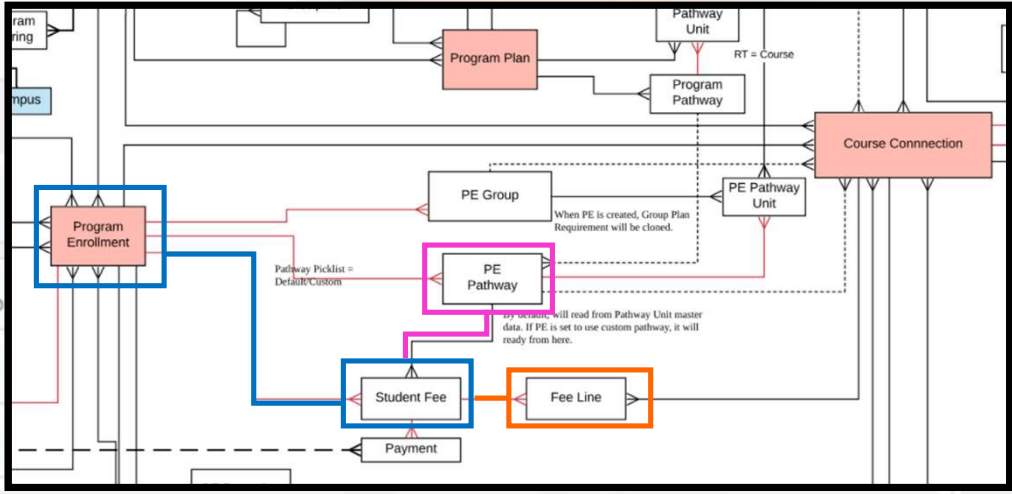

#### Fee Information

Fee Label *This field is calculated upon save*

Fee Label (Override)

\* Fee Method

\* Pay Upfront

\* Fee Type

Fee Type Option

**Fixed Term**

Program Fee	\$6,741.25
Paid Amount	\$900.00
	<i>This field is calculated upon save</i>
Outstanding Amount	\$2,900.00
	<i>This field is calculated upon save</i>

# Fees in action

Practical Example:  
One single invoice with one single line item for every enrollment Term (flat rate irrespective of Courses taken)



### Fee Method: Term-Course

Enrollment PE-0535

Contact: Sofia Student | Program: Bachelor of Music Performance and Marketing | Start Date: | GPA: 5.380

Details | Pathways | Unit Enrollments | Student Fees | PE Disciplines | Program Co

- ONE Student Fee record per each PE Pathway record
- MANY Fee Line records associated with each Student Fee record
- (As many as Course Connections are linked to the corresponding PE Pathway)

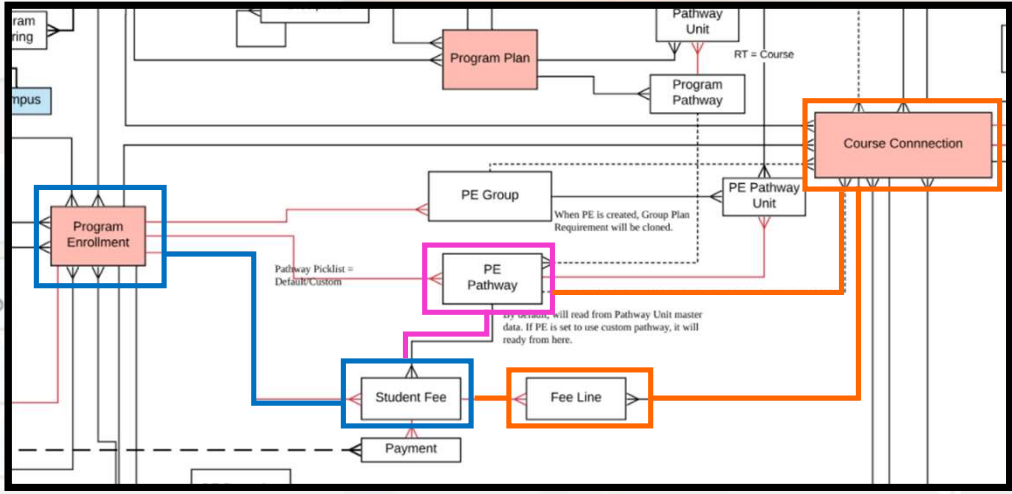

Fee Label (Override) --None--

\* Fee Method: Term - Course

\* Pay Upfront: Program

\* Fee Type: Term - Course

Fee Type Option: --None--

Program Fee	\$6,741.25
Paid Amount	\$900.00 <i>This field is calculated upon save</i>
Outstanding Amount	\$2,900.00 <i>This field is calculated upon save</i>

# Fees in action

Practical Example:  
One single invoice for every enrollment Term with as many line items as Courses enrolled for the term



# wdci

## Introduction to RIO Education: **Funding**

The Cloud Solutions Company

wdci





RIO Education Data Model v2.9

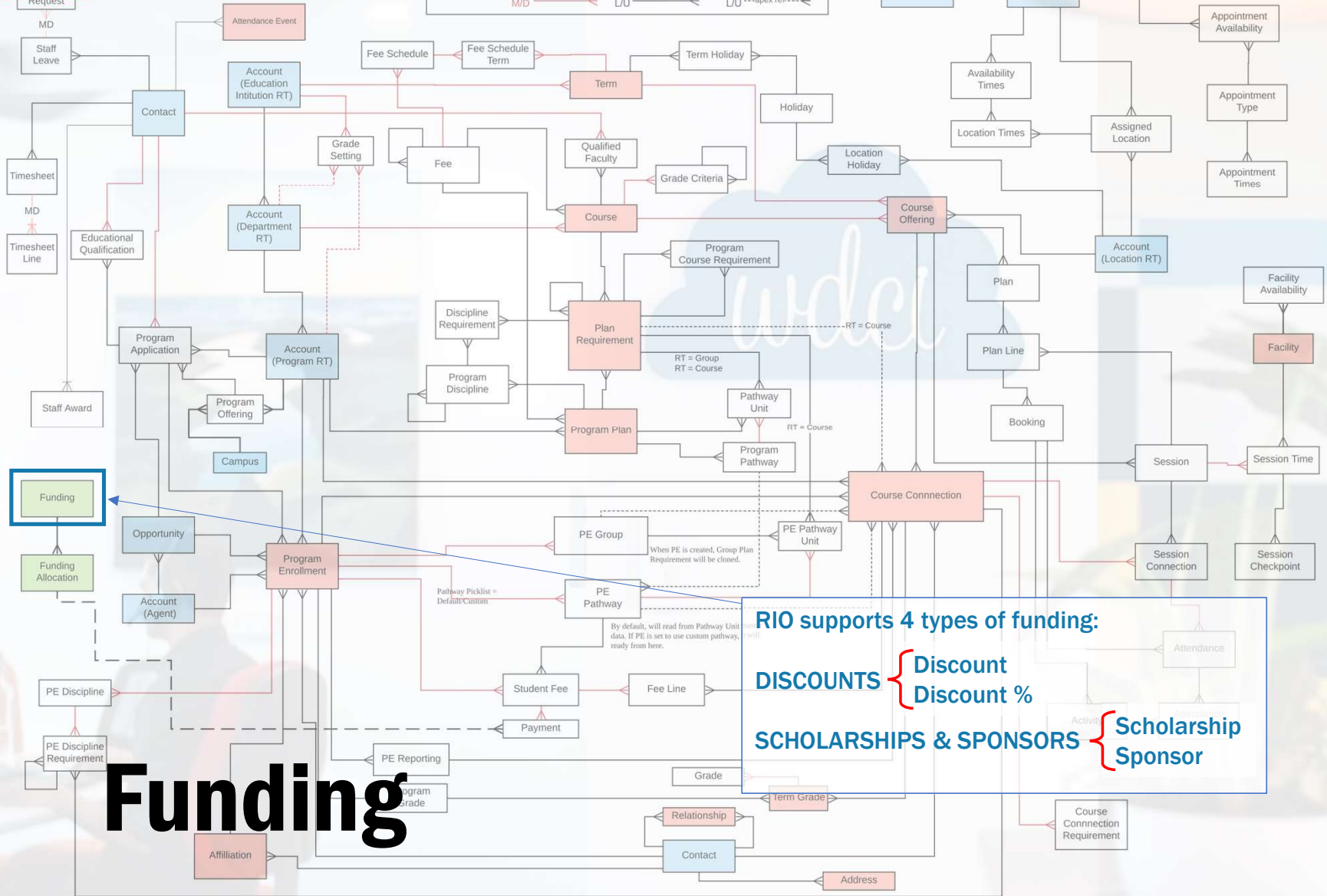
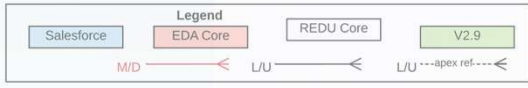

The **FUNDING** object, contains information about the different funding options available at the Educational Institution

**RIO supports 4 types of funding:**

- DISCOUNTS**
  - Discount
  - Discount %
- SCHOLARSHIPS & SPONSORS**
  - Scholarship
  - Sponsor

# Funding





## Discounts. Order of application:

- Discounts will be applied to **Student Fees** before other types of Funding
- Percent discounts will be applied before flat discounts

## How discounts work:

- RIO adds a Fee Line record with a negative amount to the Student Fee it applies to (remember that each Student Fee is a “bundle” of Fee Lines)
- These negative-amount fee lines will only discount those fee lines generated from discountable fees

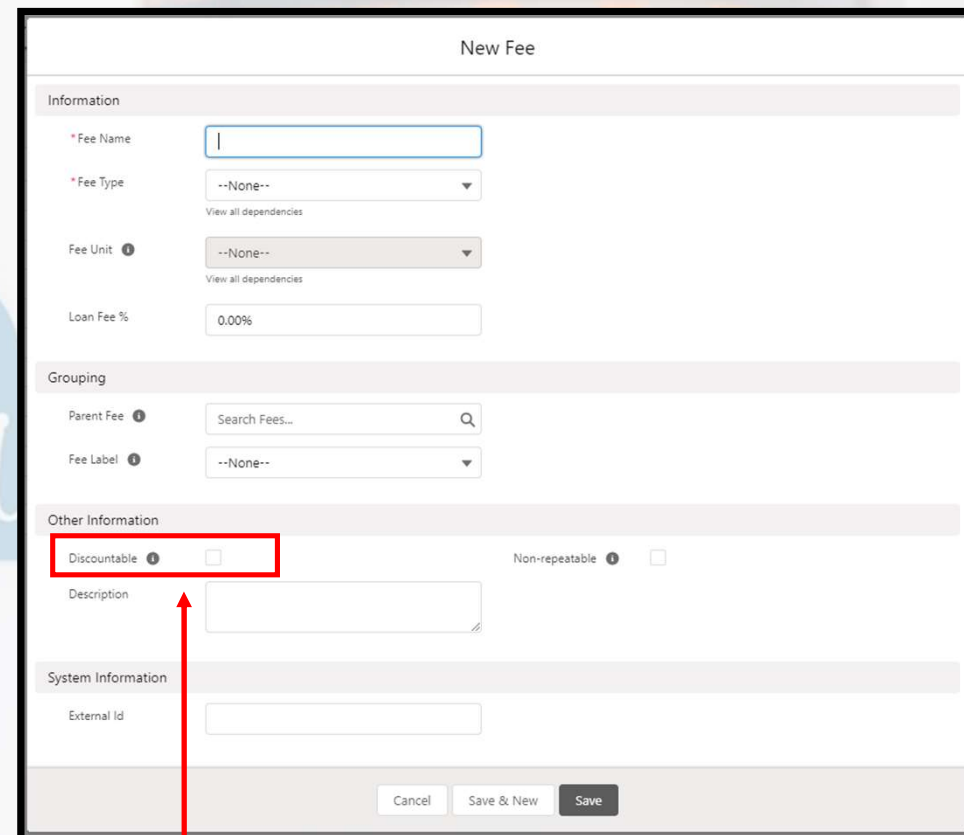

New Fee

Information

\* Fee Name

\* Fee Type

View all dependencies

Fee Unit

View all dependencies

Loan Fee %

Grouping

Parent Fee

Fee Label

Other Information

Discountable

Non-repeatable

Description

System Information

External Id

Cancel Save & New Save

## Funding: Discounts



## They apply in a similar way as discounts:

- A Fee Line record with a negative amount to the Student Fee it applies to

## The difference is:

- These types of Funding will have a limited pool of funds available, and you can disperse certain amounts to each student
- Some Fee Lines may remain to be paid in full irrespective on any Scholarships and Sponsors applied to the Student Fee

# Funding: Scholarships & Sponsors





RIO Education Data Model v2.9

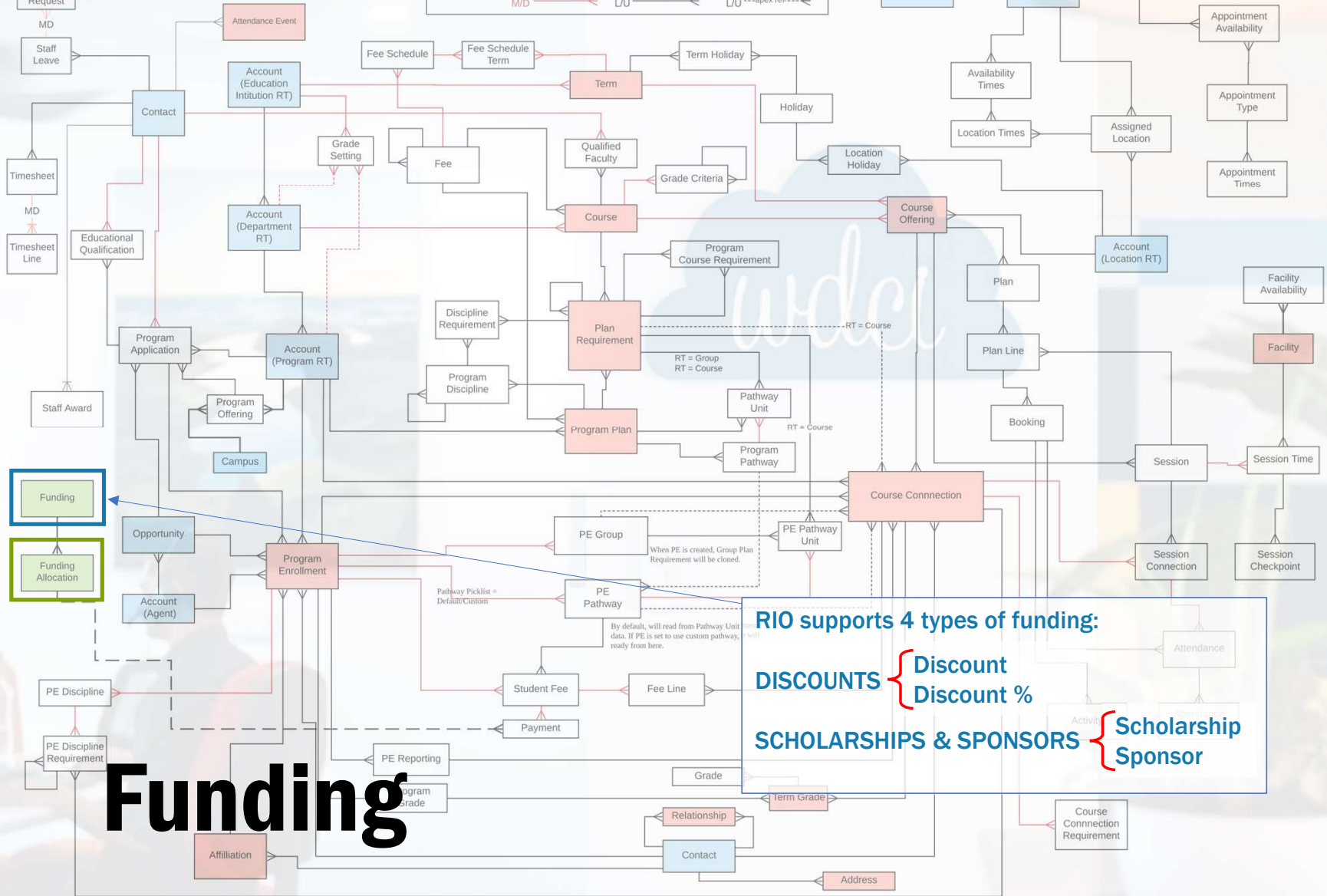
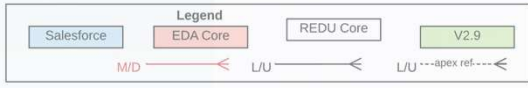

The **FUNDING** object, contains information about the different funding options available at the Educational Institution

For each type of funding, **FUNDING ALLOCATION** links a funding record to a student's program enrollment

RIO supports 4 types of funding:

- DISCOUNTS** { Discount, Discount %
- SCHOLARSHIPS & SPONSORS** { Scholarship, Sponsor

# Funding





Funding

### Leadership and Service Scholarships & Awards

**Details** Requests/Allocations

Funding Name	Leadership and Service Scholarships & Awards	Owner	Adam Administrator
Funding Type	Scholarship	Unallocated Funds	\$936,000.00
Total Fund	\$1,000,000.00	Allocated Funds	\$64,000.00
Funding Source	WDCi Group	Disbursed Funds	\$6,550.00
Description	Scholarship for Students who have displayed leadership qualities through community service	Funding Start Date	1/01/2021
Max Amount per Term	\$2,500.00	Funding End Date	31/12/2021
Max Amount per Student	\$10,000.00		
Student Selectable Amount	<input type="checkbox"/>		
Status	Ongoing		
Discount Information			
Discount Amount			
Discount %			
Created By	Adam Administrator, 5/01/2021 11:34 AM	Last Modified By	Sofia Student, 30/06/2021 1:35 PM

# Funding: Example of a Funding record



**Funding Allocation**  
FA-0000022

**Details**   Related

Funding Allocation ID	FA-0000022	Status	Approved
Funding	Leadership and Service Scholarships & Awards	Amount	\$10,000.00
Contact	Sofia Student	Disbursed Amount	\$1,000.00
Program Application		Amount Remaining	\$9,000.00
Program Enrollment	PE-0535		
Discount Percent			
Max Amount per Term	\$500.00		
Total Budget			

▼ Date Information

Application Date	18/01/2021	Start Date	
		End Date	

▼ Supporting Information

Social Org/Leadership Activities	Student Council:Sport:Band/Orchestra	Sporting Activities	Tennis All Schools Champion
Other Social Org/Leadership Activities	School Captain at NY State School	Parent/Guardian Yearly Income	80K - 100K
Achievements	Volunteer coordinator for <a href="http://familycare.org">familycare.org</a>		

▼ Additional Information

Description

▼ System Information

Created By: Sofia Student, 19/01/2021 8:42 AM      Last Modified By: Sofia Student, 30/06/2021 1:35 PM

# Funding: Example of a Funding Allocation record





**Enrollment PE-0535**

Contact: **Sofia Student** | Program: Bachelor of Business Information Systems | Start Date: [blank]

**Funding Allocation FA-00000022**

**Details** | Related

Funding Allocation ID	FA-00000022	Status	Approved
Funding	Leadership and Service Scholarships & Awards	Amount	\$10,000.00
Contact	Sofia Student	Disbursed Amount	\$1,000.00
Program Application	[blank]	Amount Remaining	\$9,000.00
Program Enrollment	PE-0535		
Discount Percent	[blank]		
Max Amount per Term	\$500.00		
Total Budget	[blank]		

**Student Fees (2)**  
2 items • Updated 2 hours ago

	Student Fee Name	Fee Descri...	Fee Status	Total Funding...	Total Upf...	Total Fee	Total Paid A...	Outstanding Am...
1	F-000000230		Partial Paid	\$500.00	\$0.00	\$1,900.00	\$900.00	\$1,000.00
2	F-000000234		Pending	\$500.00	\$0.00	\$1,900.00	\$0.00	\$1,900.00

[View All](#)

**Funding Allocations (1)** New

Funding Allocation ID	Funding Name	Funding Type	Amount
FA-00000022	Leadership and Service Scholarships & Awards	Scholarship	\$10,000.00

[View All](#)

# Funding: Program Enrollment view



## Fee method: Term-Course

A student enrolls in three courses

RIO creates one Student Fee with three Fee Lines

RIO calculates an applicable amount

A Fee Line may not add up to the applicable amount if:

- a) It originates from a non-discountable fee
- b) The Fee Line has been flagged as 'Skip Funding Allocation'

RIO checks whether there is any existing funding allocation

For each F.A., RIO creates a Fee Line that will be deducted from the applicable amount

Student Fee for the term:

- Fee Line 1
- Fee Line 2
- Fee Line 3
- (Fee Line 4)

## Funding: Example of how RIO works



# wdci

## Introduction to RIO Education: **Grades**

The Cloud Solutions Company

wdci





RIO Education Data Model v2.9

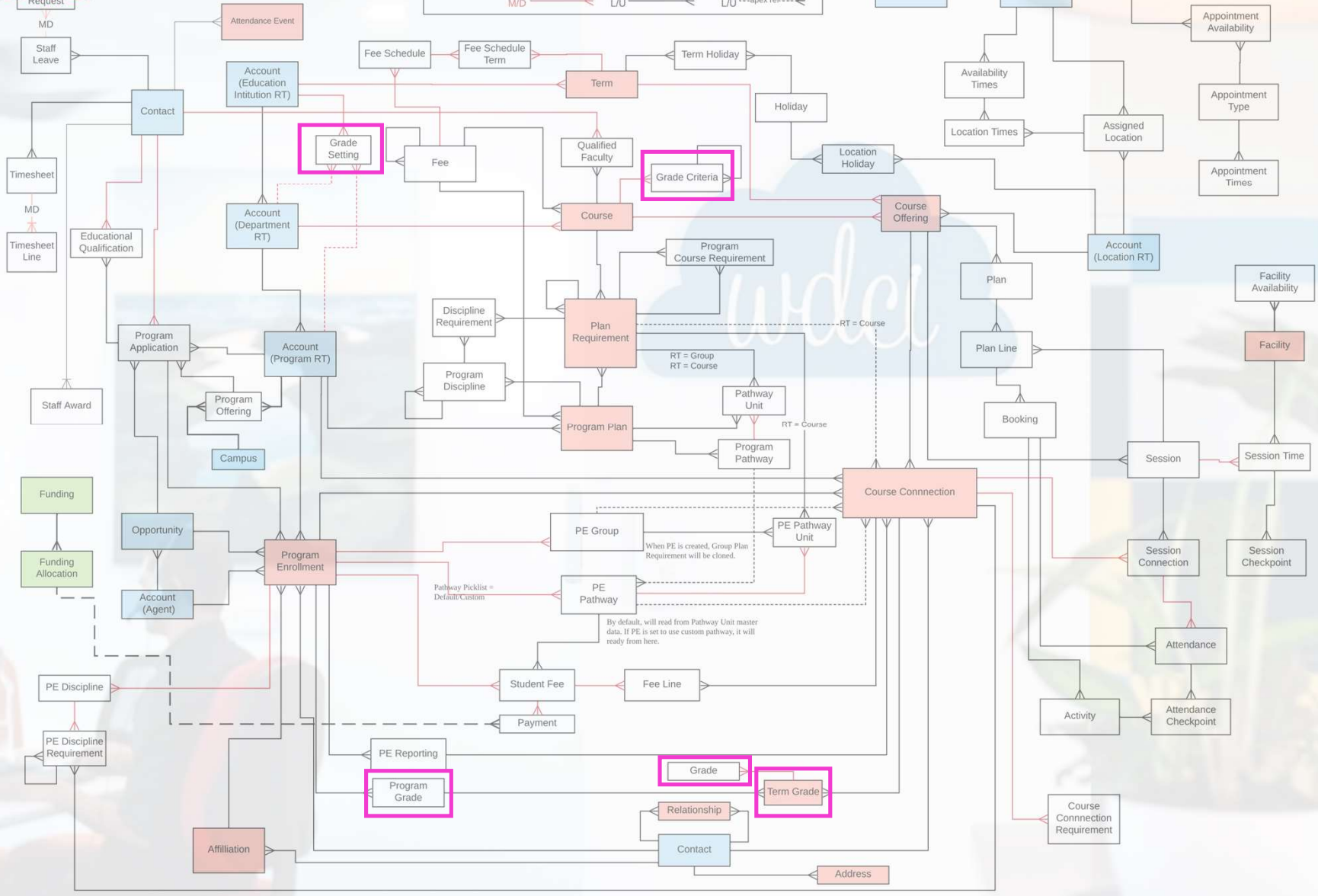
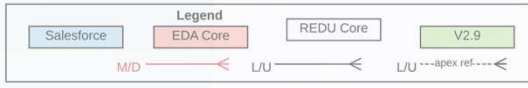

There are **FOUR** Grade objects



The grading system that is to be used is determined by Grade Setting

# Grade Setting

RIO Education Data Model v2.9

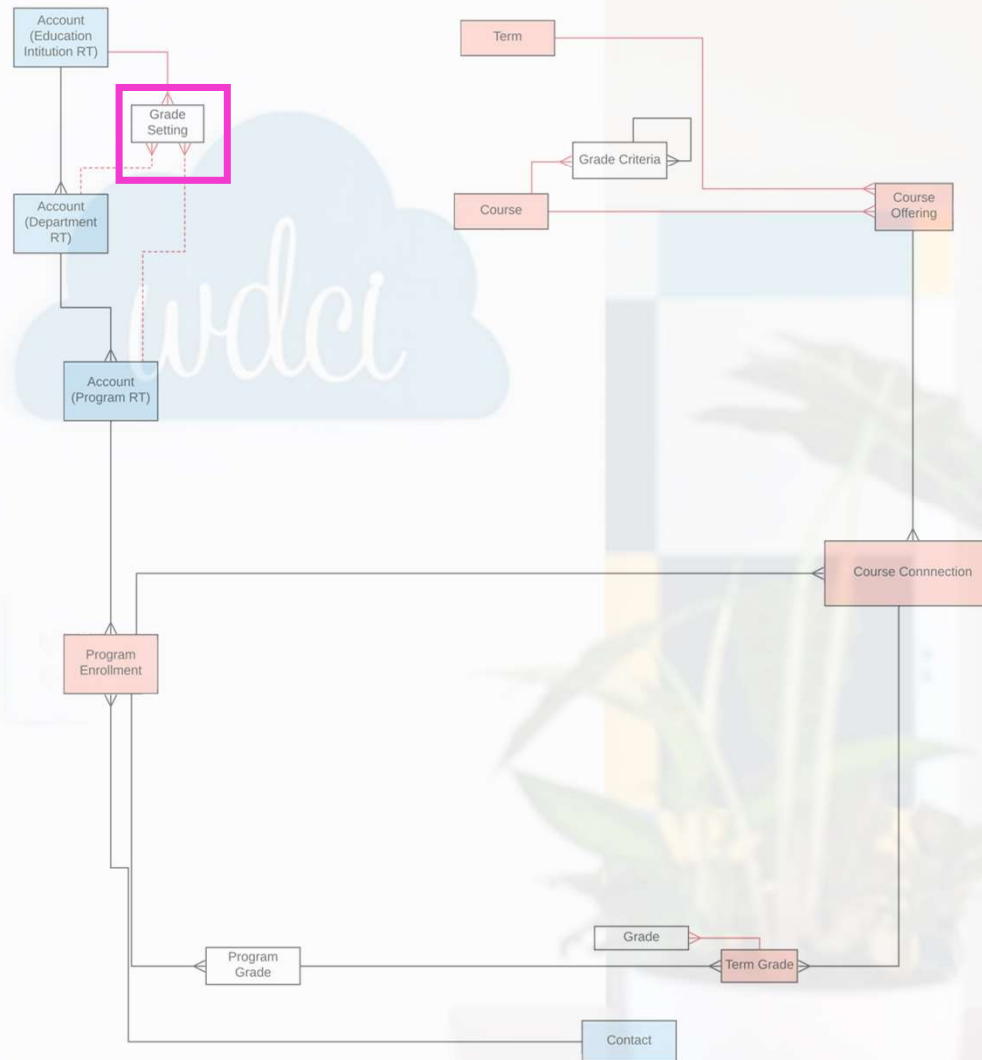



A Grade Setting is a set of parameters used to assess student learning

## Grade Setting Scope

Determines the level at which this Grade Setting applies within the Account Hierarchy:

- Educational Institution
- University Department
- Academic Program

Grade Setting Name

RU-HD

Grade Setting Scope ⓘ

Educational Institution

Grade Setting Group ⓘ

RIO University

Grade Range ⓘ

85 - 100

Grade Value ⓘ

HD - High Distinction

Grade Points ⓘ

7.0

Grade Result

Pass

# Grade Setting



A Grade Setting is a set of parameters used to assess student learning

## Grade Setting Group

Determines the entity this Grade Setting belongs to

Grade Setting Name

RU-HD

Grade Setting Scope ⓘ

Educational Institution

Grade Setting Group ⓘ

RIO University

Grade Range ⓘ

85 - 100

Grade Value ⓘ

HD - High Distinction

Grade Points ⓘ

7.0

Grade Result

Pass

# Grade Setting



A Grade Setting is a set of parameters used to assess student learning

## Grade Range

This is the numerical range that faculty can use to mark any student piece of assessment

Grade Setting Name

RU-HD

Grade Setting Scope ⓘ

Educational Institution

Grade Setting Group ⓘ

[RIO University](#)

Grade Range ⓘ

85 - 100

Grade Value ⓘ

HD - High Distinction

Grade Points ⓘ

7.0

Grade Result

Pass

# Grade Setting



A Grade Setting is a set of parameters used to assess student learning

Grade Setting Name	Grade Range ⓘ
RU-HD	85 - 100
Grade Setting Scope ⓘ	Grade Value ⓘ
Educational Institution	HD - High Distinction
Grade Setting Group ⓘ	Grade Points ⓘ
RIO University	7.0
	Grade Result
	Pass

## Grade Value Grade Points

These are the alphanumeric and the numeric indicators of student performance to be shown in the official transcript as a result of the Grade Range given by the faculty

# Grade Setting



A Grade Setting is a set of parameters used to assess student learning

Grade Setting Name

RU-HD

Grade Setting Scope ⓘ

Educational Institution

Grade Setting Group ⓘ

[RIO University](#)

Grade Range ⓘ

85 - 100

Grade Value ⓘ

HD - High Distinction

Grade Points ⓘ

7.0

Grade Result

Pass

## Grade Result

This is the indicator that shows whether the student has met the Plan Requirement to keep progressing toward their program completion

# Grade Setting







RIO Education Data Model v2.9

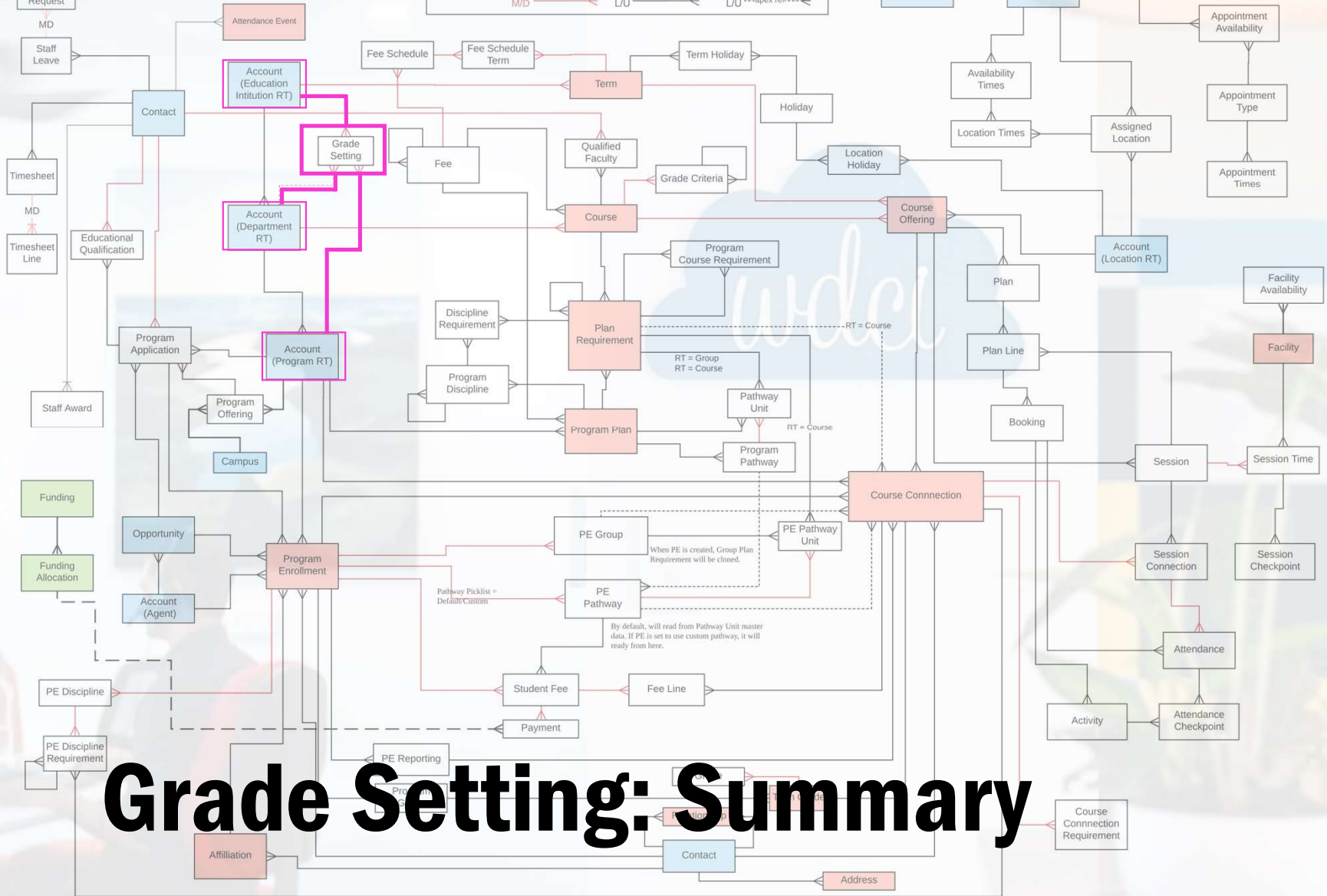
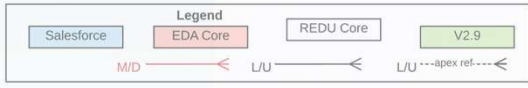

What marking systems are available at **Institution, Department and Program level?**



**Grade Settings**

# Grade Setting: Summary



The different concepts (and their weightings) we can grade against is determined by **Grade Criteria**

# Grade Criteria

RIO Education Data Model v2.9

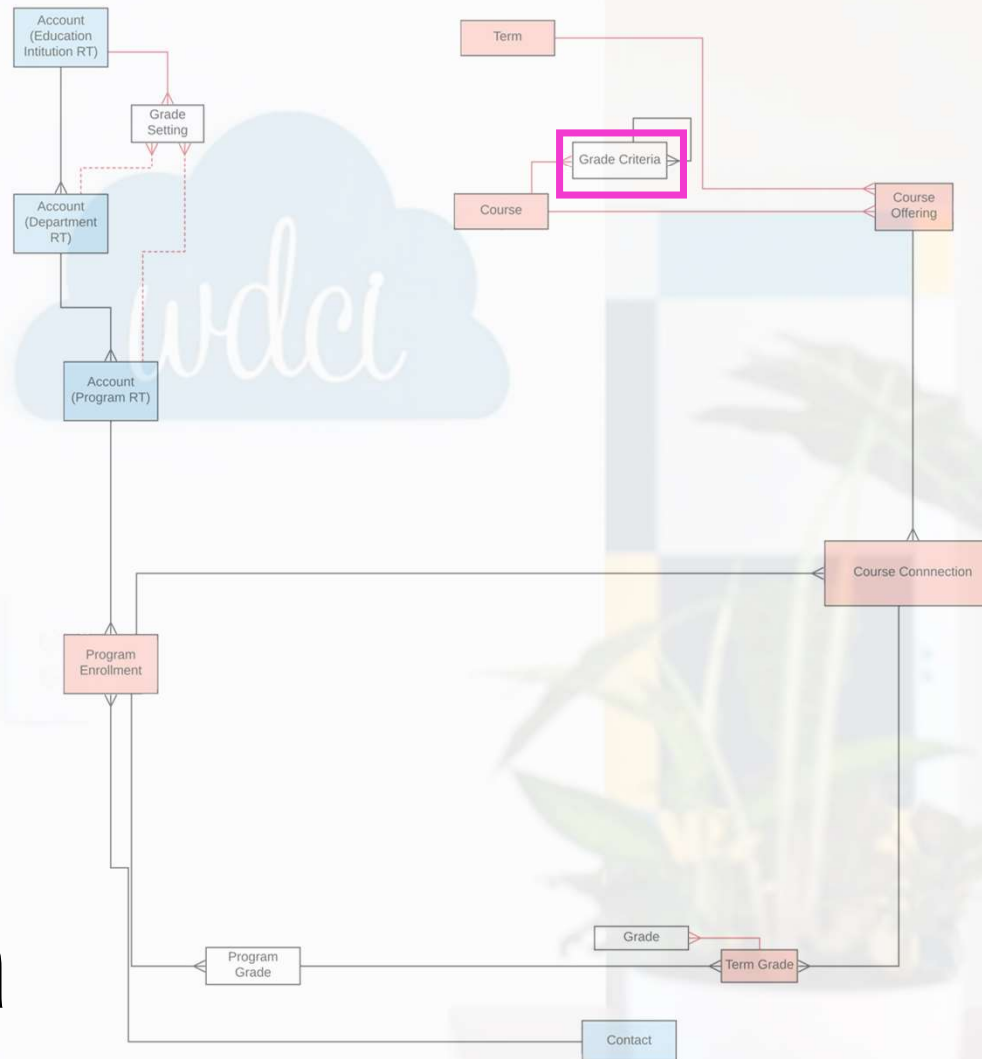
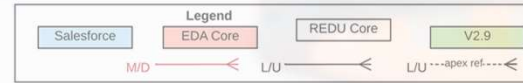

Grade Criteria provides the option to break down a Course's final grade into components with a contribution percentage

Unit  
**BUS101: Business Analytics**

Unit ID: BUS101  
Department: School of Business  
Credit Hours: 10.000

- Details
- Unit Offerings
- Qualified Faculty
- Academic Programs
- Grade Criteria**
- Session Templates

Grade Criteria (2)

New

Grade Criteria Name	Weight	Parent Grade Criteria
Group Assignment work	40.00%	
Group Activity	60.00%	

[View All](#)

# Grade Criteria



Grade Criteria provides the option to break down a Course's final grade into components with a contribution percentage

Academic Programs **Grade Criteria** Session Templates Activity Chatter

New Grade Criteria

Information

\*Grade Criteria Name

\*Unit

Parent Grade Criteria

Weight

Cancel Save & New Save

## Parent Grade Criteria

Parent-child relationships may also be created between Grade Criteria, for example:

- Assignments
  - Assignment 1
  - Assignment 2

# Grade Criteria



**We have set out what grading system we are going to use and what concepts we are going to grade against...**

**Now, where do we keep the actual grades?**

**Term Grade / Grade**





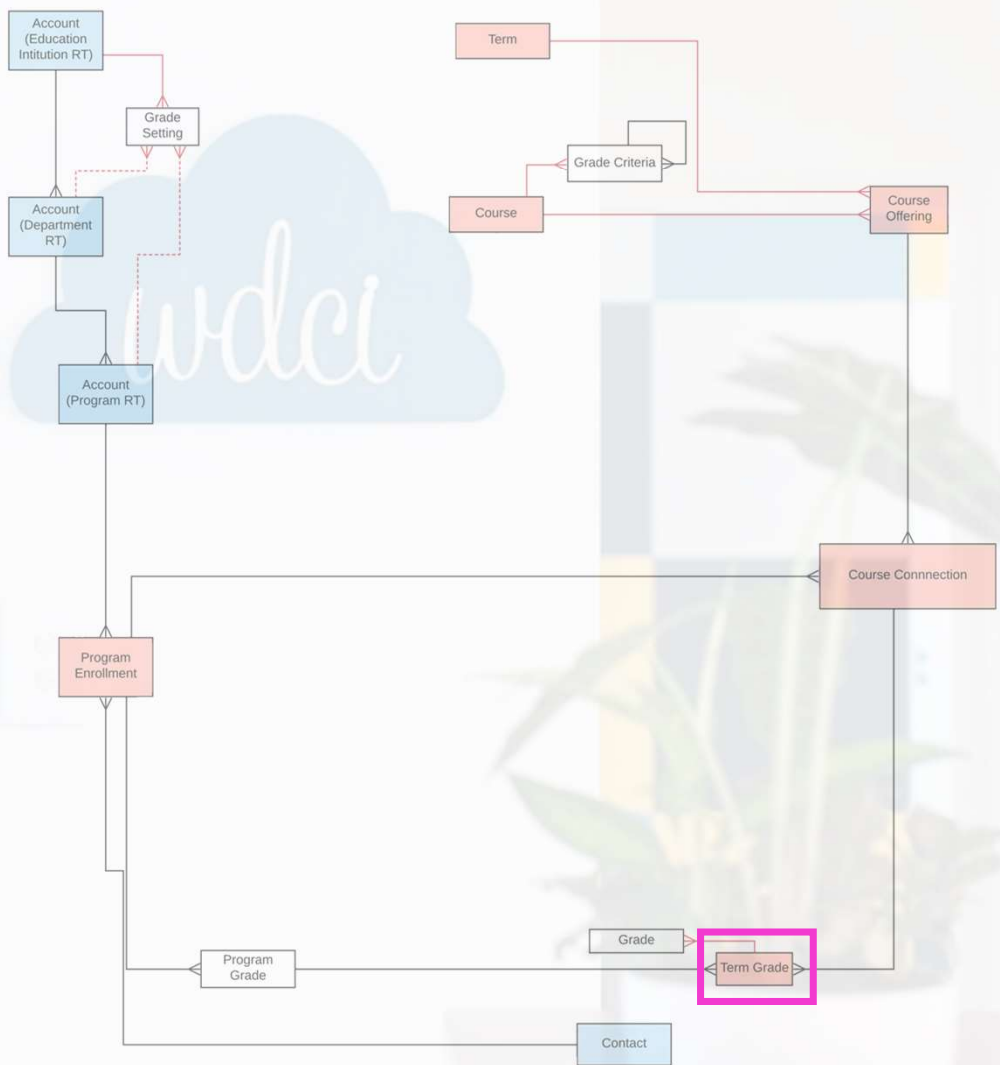

# Term Grade



## Term Grade is EDA's original grade management object

2018 Program Enrollment ID PE-0025 Grade 80.00 Primary

### New Term Grade

Information

Term Grade N

Unit Enrollment  ×

Term  Q

Week

Term Grade Type

Result

Owner Adam Administrator

Credits Attempted

Credits Earned

Letter Grade

Numerical Grade

Percent Grade

Cancel Save & New Save

Term Grade links a grade with the Course Connection it applies to

# Term Grade



## Term Grade is EDA's original grade management object

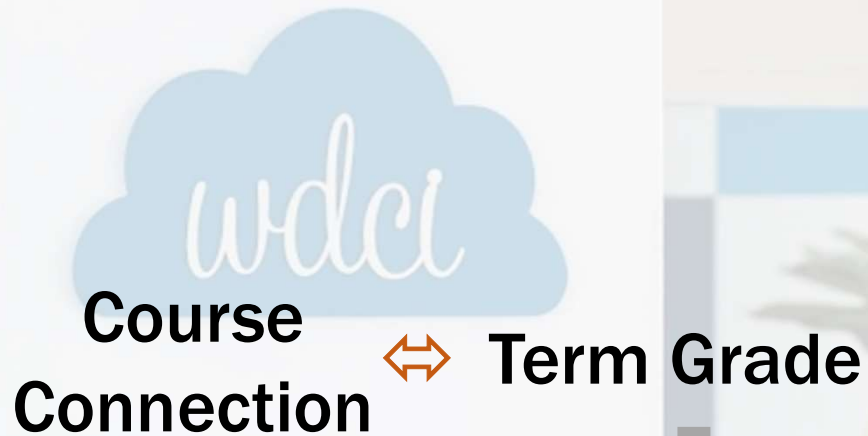
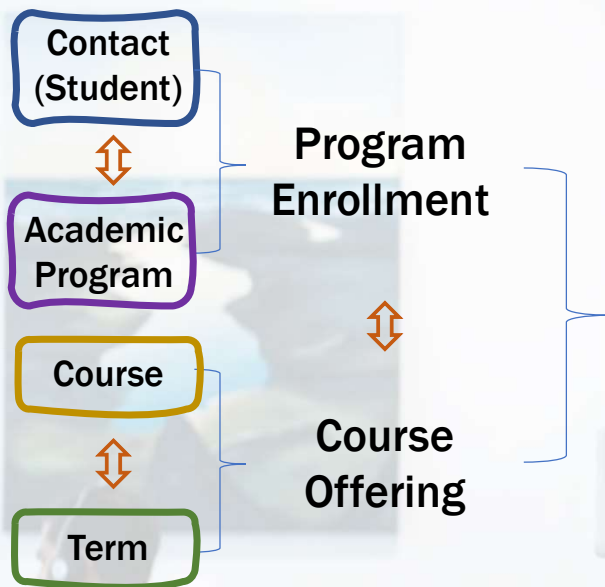

Term Grade gives us the grade of a **student** who is taking a particular **course** that is offered in a specific **term** as a requirement to complete a specific **Program**

# Term Grade



# Term Grade is EDA's original grade management object

1 2018    Program Enrollment ID PE-0025    Grade 80.00    Primary

### New Term Grade

Information

Unit Offering

Term  Search Terms...

Week

Term Grade Type

Result

Owner Adam Administrator

Credits Attempted

Credits Earned

Letter Grade

Numerical Grade

Percent Grade

Cancel    Save & New    Save

Term Grade also links a grade with a term within the Course

 Term was already implicit in Unit Offering, wasn't it?  
**Wait a minute...**

# Term Grade





EDA Product Documentation

- > Get Started with EDA
- > Get Oriented to the EDA Data Model
- > Install EDA
- > Set Up Security
- > Configure EDA
- > Add Your School's Data
- ▼ EDA Objects
  - Account
  - Address
  - Affiliation
  - Application
  - Attendance Event
  - Attribute
  - Behavior Involvement
  - Behavior Response
  - Case
  - Contact
  - Contact Language
  - Course
  - Course Connection
  - Course Offering
  - Course Offering Schedule
  - Education History
  - Facility
  - Language
  - Lead

# Term Grade



Product Documentation

## Term Grade

### New Term Grade

Information

Term Grade Name		Owner	Adam Administrator
Unit Enrollment	CC-0469	Credits Attempted	
Term	Search Terms...	Credits Earned	
Week	Recent Terms	Letter Grade	
Term Grade Type	Semester 1 2021 1/03/2021	Numerical Grade	
Result	Semester 1 2020 1/03/2020	Percent Grade	
	Semester 2 2021 30/08/2021		
	Semester 2 2020 31/08/2020		
	Semester 1 2018 1/03/2018		
	+ New Term		

Save & New Save



# Term Grade is EDA's original grade management object

Several Term Grades can be linked to the same Course (for a particular student)

Unit Enrollment  
CC-0469

Contact: Sarah Smith | Unit Offering ID: Sydney Campus - BUS101 Year 2018 | am Enrollment ID: 025 | Grade: 80.00 | Primary:

Details | Sessions | Fee Lines | Requirements | **Term Grades** | History

Term Grades (4) New

Term Grade Name	Term	Week	Result
TG-0001	Quarter 1 2018		
TG-0002	Quarter 2 2018		
TG-0003	Quarter 3 2018		
TG-0004	Quarter 4 2018		

[View All](#)

for instance, let's see this one

# Term Grade



## Term Grade is EDA's original grade management object

For every record in Term Grade that we link to the Course Connection we can specify **WHAT milestone** this grade refers to

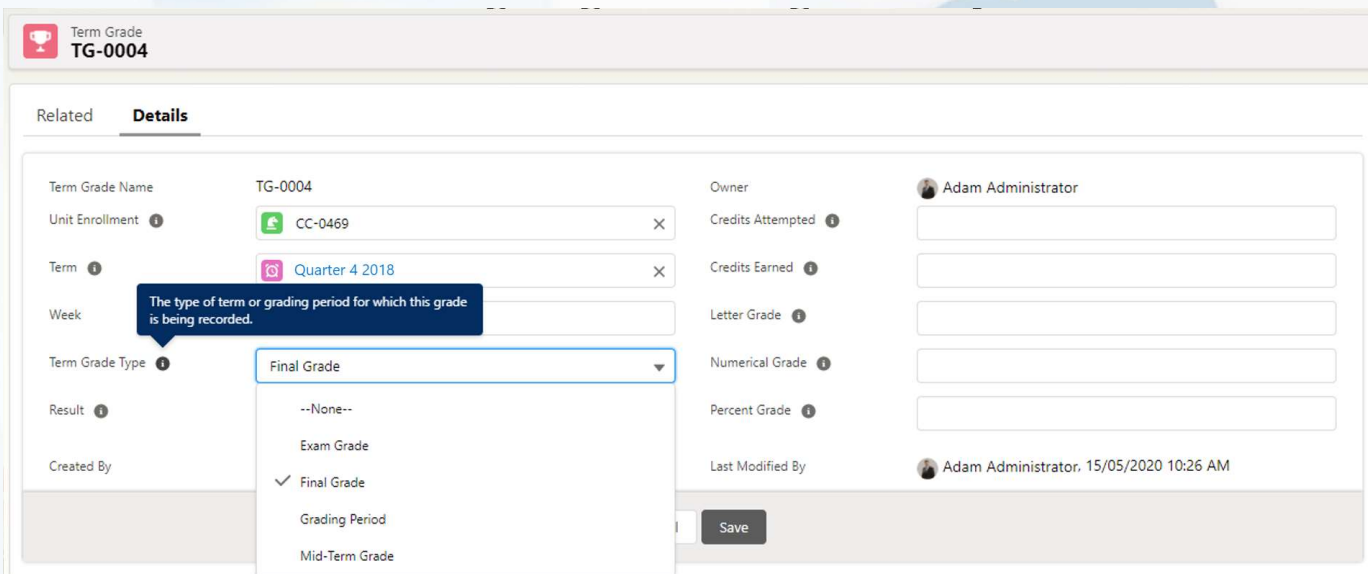

Term Grade  
TG-0004

Related **Details**

Term Grade Name: TG-0004

Unit Enrollment: CC-0469

Term: Quarter 4 2018

Week:

Term Grade Type: Final Grade

Result: --None--  
Exam Grade  
✓ Final Grade  
Grading Period  
Mid-Term Grade

Owner: Adam Administrator

Credits Attempted:

Credits Earned:

Letter Grade:

Numerical Grade:

Percent Grade:

Last Modified By: Adam Administrator, 15/05/2020 10:26 AM

Save

The type of term or grading period for which this grade is being recorded.

# Term Grade



## Term Grade is EDA's original grade management object

### Use case:

- We have a course that runs yearly
- The final grade for the course will depend on the quarterly grades
- Each quarterly grade breaks down into:
  - individual-work grade
  - group-work grade

















# Term Grade



## Term Grade is EDA's original grade management object

 Term Grade  
**TG-0004**

Related **Details**

Term Grade Name	TG-0004	Owner	 Adam Administrator
Unit Enrollment 	 CC-0469 	Credits Attempted 	<input type="text"/>
Term 	 Quarter 1 2018 	Credits Earned 	<input type="text"/>
Week	<input type="text"/>	Letter Grade 	<input type="text"/>
Term Grade Type 	<input type="text" value="--None--"/> 	Numerical Grade 	<input type="text"/>
Result 	<input checked="" type="checkbox"/> --None--	Percent Grade 	<input type="text"/>
Created By	<input type="text"/>	Last Modified By	 Adam Administrator, 15/05/2020 10:26 AM

# Term Grade



## Grade is a RIO object that broadens Term Grade's capabilities

### Use case:

- We have a course that runs yearly
- The final grade for the course will depend on the quarterly grades
- Each quarterly grade breaks down into:
  - individual-work grade
  - group-work grade
- **The Individual-work breakdown is:**
  - 40% assignment work
  - 60% exam
- **The Group-work breakdown is:**
  - 40% group assignment work
  - 60% group activity

# Grade







Term Grade  
**TG-0004**

Related Details

Term Grade Name	TG-0004
Unit Enrollment ⓘ	CC-0469
Term ⓘ	Quarter 1 2018
Week	
Term Grade Type ⓘ	Group work grade
Result ⓘ	
Created By	Adam Administrator, 15/05/2020 10:26 AM

Owner	Adam Administrator
Credits Attempted ⓘ	
Credits Earned ⓘ	
Letter Grade ⓘ	
Numerical Grade ⓘ	
Percent Grade ⓘ	
Last Modified By	Adam Administrator, 15/05/2020 10:26 AM

# Grade



These are the concepts we have set up previously at **Grade Criteria**

 Term Grade  
**TG-0004**

**Related** Details

 **Grades (2)**

New

Grade Name	Grade Value	Grade Points	Weight
Group Assignment work		56.000	40.00%
Group Activity		62.000	60.00%

[View All](#)

# Grade



## Grade is a RIO object that broadens Term Grade's capabilities

### Use case:

- We have a course that runs yearly
- The final grade for the course will depend on the quarterly grades
- Each quarterly grade breaks down into:
  - individual-work grade
  - group-work grade
- The Individual-work breakdown is:
  - 40% assignment work
  - 60% exam
- The Group-work breakdown is:
  - 40% group assignment work
  - 60% group activity

A1 (25%)  
A2 (25%)  
A3 (25%)  
A4 (25%)

# Grade



Term Grade  
**TG-0004**

**Related** Details

**Grades (2)**

Grade Name  
[Group Assignment work](#)  
[Group Activity](#)

### New Grade: Sub Grade

Information

Record Type: Sub Grade

\* Grade Name:

\* Term Grade:

Grade Points:

Grade Value:

\* Parent Grade:

Weight:

Save

- The Group-work breakdown is:
    - 40% group assignment work
    - 60% group activity
- A1 (25%)  
A2 (25%)  
A3 (25%)  
A4 (25%)

# Grade







RIO Education Data Model v2.9

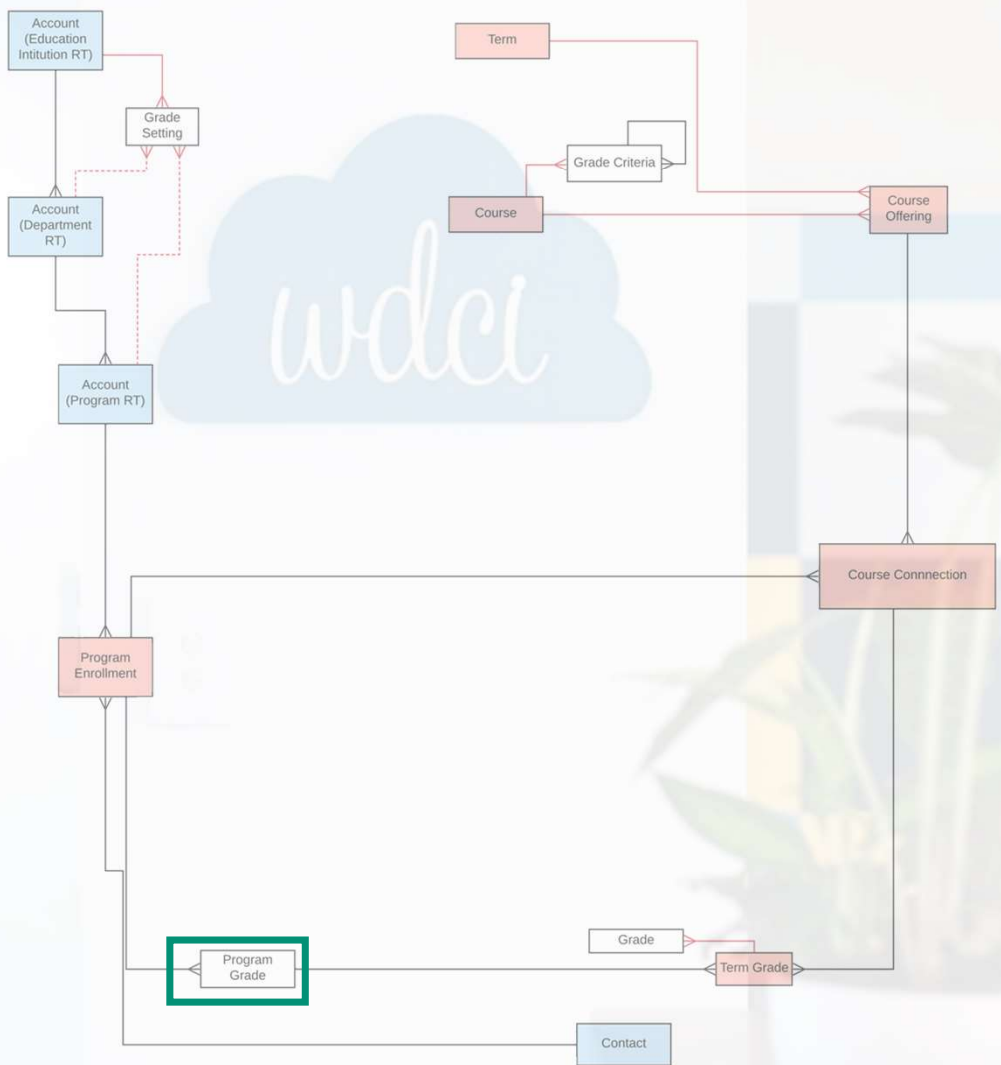
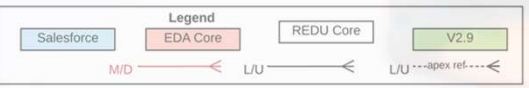

# Program Grade

is a provision in RIO for the time being

It is intended to cater for a single view for all grades in a Program Enrollment

# Program Grade



*wdci*

*The Cloud Solutions Company*

**Thanks for your attention**

